

Clay-Based Pellets for Use in Tunnel Backfill and as Gap Fill in a Deep Geological Repository: Characterisation of Thermal-Mechanical Properties

NWMO TR-2012-05

December 2012

C-S. Kim¹, A. Man², D. Dixon¹, E. Holt³, A. Fritzell⁴

¹ Atomic Energy of Canada Limited

² Golder Associates Ltd., Winnipeg, Canada

³ VTT Technical Research Centre of Finland, Finland

⁴ ES Konsult, Sweden

nwmo

NUCLEAR WASTE
MANAGEMENT
ORGANIZATION

SOCIÉTÉ DE GESTION
DES DÉCHETS
NUCLÉAIRES

Nuclear Waste Management Organisation
22 St. Clair Avenue East, 6th Floor
Toronto, Ontario
M4T 2S3
Canada

Tel: 416-934-9814
Web: www.nwmo.ca

Clay-Based Pellets for Use in Tunnel Backfill and as Gap Fill in a Deep Geological Repository: Characterisation of Thermal-Mechanical Properties

NWMO TR-2012-05

December 2012

C-S. Kim¹, A. Man², D. Dixon¹, E. Holt³, A. Fritzell⁴

¹ Atomic Energy of Canada Limited

² Golder Associates Ltd., Winnipeg, Canada

³ VTT Technical Research Centre of Finland, Finland

⁴ ES Konsult, Sweden

Disclaimer:

This report does not necessarily reflect the views or position of the Nuclear Waste Management Organisation, its directors, officers, employees and agents (the "NWMO") and unless otherwise specifically stated, is made available to the public by the NWMO for information only. The contents of this report reflect the views of the author(s) who are solely responsible for the text and its conclusions as well as the accuracy of any data used in its creation. The NWMO does not make any warranty, express or implied, or assume any legal liability or responsibility for the accuracy, completeness, or usefulness of any information disclosed, or represent that the use of any information would not infringe privately owned rights. Any reference to a specific commercial product, process or service by trade name, trademark, manufacturer, or otherwise, does not constitute or imply its endorsement, recommendation, or preference by NWMO.

ABSTRACT

Title: Clay-Based Pellets for Use in Tunnel Backfill and as Gap Fill in a Deep Geological Repository: Characterisation of Thermal-Mechanical Properties
Report No.: NWMO TR-2012-05
Authors: C-S. Kim¹, A. Man², D. Dixon¹, E. Holt³, A. Fritzell⁴
Company: ¹ Atomic Energy of Canada Limited, ² Golder Associates Ltd. ³ VTT Technical Research Centre of Finland, Finland, ⁴ ES Konsult, Sweden
Date: December 2012

Abstract

Pellets composed of bentonite-based materials are being considered by NWMO, Posiva and SKB for use in filling the rock-buffer annular gap in the In-Floor Borehole placement geometry, as a component in tunnel backfilling, and as a chamber filling material for the Horizontal Tunnel Placement (HTP) geometry. The range of locations where pellets could be used in a repository means that different types of pellets may be used since the primary functional requirements of the pellets will vary. Preliminary work has revealed that it is difficult to place pellets in repository simulation trials and achieve as-placed dry density of 1.4 Mg/m³ and target thermal conductivity for this type of sealing material. Thermal conductivity of these materials tend to be low (generally <0.5 W/(m·K)), which limits the rate of heat transfer from the used fuel to the surrounding rock. This has implications on the temperature developed in a repository and the spacing of the used fuel to prevent excessive temperatures. Improving the thermal conductivity of clay-based pellet fill material is therefore highly desirable.

The objective of this work was to improve the quality of bentonite based pellets to better meet the heat transfer requirements of the placement concepts being considered by NWMO, Posiva and SKB. A range of pellet sizes, shapes and the effects of various volumetrically inert fillers on the properties of bentonite-based materials were examined. The pellets produced all had individual pellet densities in the order of 2.0 Mg/m³. When loosely poured, the dry density of the fill typically was in the order of 1.1 to 1.2 Mg/m³. This could be improved to ~1.4 Mg/m³ using vibratory compaction. Pellets made with silica sand and illite additives had dry densities slightly higher than this. However, pellets containing additives have lower EMDDs than 100% bentonite which adversely affects their hydraulic conductivities and swelling pressures. The addition of Wyoming bentonite fines (i.e., 80 mesh granules), vibrated into the pore space between the pellets increased dry density to >1.5 Mg/m³.

The presence of silica sand and illite in the pellets resulted in only a small increase in the measured thermal conductivity of a mass of dry pellets relative to pellets made with 100% bentonite. Increasing the overall density through vibratory compaction had a greater effect on increasing thermal conductivity than the additives. However, maximum values measured on pellets densified by vibratory compaction were close to 0.6 W/(m·K) and appears to be the maximum achievable for as-placed pellets without the addition of fines to the void space between the pellets or artificial wetting. This value can therefore be used as a lower bounding limit for thermal assessments of the in-floor borehole's gap fill in the KBS-3V geometry as well as tunnel backfill where there is no immediate water influx (dry borehole). The vibration of Wyoming bentonite fines (80 mesh granules) into a pellet-filled volume typically provided a slight improvement to the thermal conductivity to slightly less than 0.7 W/(m·K).

DEFINITION OF TERMS

The discussion contained in this document includes use of terms that are not uniformly applied in the programs of NWMO, SKB, and Posiva. As a result, a brief description of some of the key terms and the manner they are used is provided below. It should be noted that unless otherwise specified in the text, NWMO terminology is used in this document.

AECL – Atomic Energy of Canada Limited.

Backfill – Term is used in this document to define any clay-based material installed in the placement tunnels, access tunnels, shafts or other locations in a repository. Its composition may vary depending on its location and functional requirements.

Bentonite – The trade-name used to describe commercially marketed, smectite-rich clay, typically dominated by the clay mineral Montmorillonite.

BSB – Bentonite-Sand Buffer.

Buffer – Highly compacted bentonite material installed immediately adjacent to the UFC in the IFB placement geometry. It is typically defined as being a densely pre-compacted bentonite clay installed within the placement borehole.

Canister – Term used by Posiva/SKB to describe the Used Fuel Container (UFC), also referred to as Container in NWMO terminology.

EBS – Engineered Barrier System.

EMDD – Effective Montmorillonite Dry Density. A normalising parameter used to express the density of the swelling clay component after factoring out mass and volume of non-swelling clay solids. The equation for this parameter is provided on page 18 of the document.

FSI - Free Swell Index. A parameter used to describe the volume that a material will occupy when allowed unlimited access to free water and unconfined. Parameter is usually expressed as mL/2gm of dry soil.

Highly Compacted Bentonite (HCB) – Material produced by densely compacting bentonite clay (a dried and crushed, smectite-rich shale) into desired shapes for use immediately adjacent to the UFC (buffer rings and cylinders, clay pellets). There is no specific density associated with this material, rather it is a generic descriptor for an artificially densified bentonite mass.

Horizontal Tunnel Placement (HTP) – The UFC placement geometry proposed by NWMO for use in a sedimentary environment. It consists of a UFC installed on its side in a deposition tunnel excavated to hold a series of these UFCs.

In Floor Borehole (IFB) – The UFC placement geometry proposed by NWMO for use in a crystalline rock environment where the UFC is installed in a placement borehole drilled in the floor of the placement room. This is the same geometry as the deposition borehole defined for the KBS-3V concept by SKB and Posiva.

KBS-3V – The in-floor, vertical canister placement geometry proposed for use by SKB/Posiva.

NAGRA – Translates to “National Cooperative for the Disposal of Radioactive Waste” (Switzerland).

NWMO – Nuclear Waste Management Organisation (Canada).

Pellets – Pre-manufactured, clay-based material, typically composed of bentonite-rich clay that is processed into uniformly-sized, high-density aggregations that are used to fill spaces and gaps associated with the buffer and backfill.

Ps – Swelling Pressure.

TDS – Total Dissolved Solids. The quantity of soluble materials in a solution. Typically expressed as gm/L of solution or % of solution mass.

UFC (Used Fuel Container) – The corrosion-resistant component of the engineered barriers system used to hold the used fuel assemblies in NWMO’s repository terminology. It is the same component as that referred to as the Canister in the SKB/Posiva concepts.

URL – Underground Research Laboratory.

TABLE OF CONTENTS

	<u>Page</u>
ABSTRACT	v
DEFINITION OF TERMS	vii
1. BACKGROUND	1
2. OBJECTIVES OF STUDY	3
3. PREVIOUSLY COMPLETED PELLET DEVELOPMENT STUDIES	5
3.1 BACKGROUND	5
3.2 IMPROVING AS-PLACED DENSITY OF PELLET FILL: NWMO'S 2010 PELLET STUDY	7
3.2.1 Pellet Materials Examined	7
3.2.2 Pellet Manufacturing Trials	9
3.2.3 Densification of Pellet Fill	11
3.2.4 Development of Pellet-Granulate Blends to Improve As-placed Density and Thermal Conductivity	12
3.3 CHARACTERISATION OF THERMAL PROPERTIES OF PELLET MATERIALS: 2010 NWMO PELLET OPTIMISATION STUDY.....	13
3.3.1 Thermal Conductivity Evaluation	13
3.3.2 Improving the Thermal Conductivity of Individual Pellets	13
3.4 SUMMARY OF RESULTS FROM 2010 STUDIES	18
4. CURRENT (2011) STUDY	19
4.1 BACKGROUND	19
4.2 TEST MATRIX	20
4.3 MATERIALS AND METHODS.....	24
4.3.1 Materials Examined in Study (Bentonite, Illite, Silica Sand)	24
4.3.2 Pellet Manufacturing	25
4.3.3 Pellet Testing	33
5. RESULTS OF PELLET TESTING	41
5.1 VISUAL CHARACTERISATION	41
5.2 PELLET DENSITY	43
5.3 FREE SWELL TESTS.....	49
5.4 CRUSH STRENGTH OF INDIVIDUAL PELLETS	52
5.5 AS-PLACED DENSITY OF Poured PELLETS	58
5.6 ABRASION TESTS.....	65
5.7 THERMAL PROPERTIES TESTING	67
5.7.1 Thermal Properties of Poured and Vibratory-Densified Pellet Fills	67
5.7.2 Effect of Bentonite Type on Thermal Properties.....	68
5.7.3 Effect of Additives to Clay	68
5.7.4 Effect of Pellet Size on Thermal Conductivity.....	68
5.7.5 Effect of Fines Addition	68
5.7.6 Summary	70
6. DISCUSSION AND CONCLUSIONS.....	71
ACKNOWLEDGEMENTS	74

REFERENCES 75
APPENDIX A: MATERIAL DESCRIPTIONS AND MANUFACTURERS' DATA SHEETS 79
APPENDIX B: RESULTS OF PELLET TESTING: DATA TABLES 89

LIST OF TABLES

	<u>Page</u>
Table 1: Gap Fill in IFB and HTP Geometries: Parameters and Properties of Primary Interest ..	3
Table 2: Pellets Produced using Different Compression Pressures	9
Table 3: Comparison of Densification Achieved Using Commercially Available and Specially- Manufactured Pellets (after Man et al. 2011)	10
Table 4: Test and Production Matrix for Pellets for Potential use in Gap-filling (IFB and HTP geometries)	22
Table 5: Test and Production Matrix for Pellets for Possible use in Tunnel Backfill	23
Table 6: Summary of Products used in Pellet Optimisation Project.....	26
Table 7: Properties of Materials Investigated in Pellet Optimization Project.....	27
Table 8: Pellet Production Matrix	31
Table 9: Pellet Densities for Wyoming Bentonite and Bentonite-filler Materials Evaluated for Potential Suitability for use in Gap Filling.....	45
Table 10: Densities Achieved for Individual Clay-only Pellets Evaluated as a Potential Component in Tunnel Backfill	46
Table 11: Poured and Vibrated Densities of Clay-only Pellets	62
Table 12: Poured and Vibrated Densities of Pellets Containing Non-bentonite Component	63
Table 13: Density and Moisture Content Results from Tests by VTT, Finland	64
Table 14: Results of MicroDeval Test.....	65
Table 15: Results of Wear Resistance Tests.....	66
Table 16: Thermal Conductivity of Pellet Fills.....	69

LIST OF FIGURES

	<u>Page</u>
Figure 1: Vertical Container Placement Geometry (after TKS 2009) being considered by NWMO (In-floor borehole (IFB)), SKB (KBS-3V), and Posiva. The container, a bentonite buffer surrounding the canister and the materials used for backfilling the deposition tunnels are shown.	1
Figure 2: Horizontal Tunnel Placement (HTP) Geometry considered by NWMO	2
Figure 3: Results of an Illustrative Model showing the Effect of Thermal Conductivity of the Engineered Clay Barrier in the HTP Method on the Required Tunnel Spacing to Prevent Excessive Heat Build-Up.....	6
Figure 4: Pellets Examined by Dixon et al. (2005) and Man et al. (2011) Pellet Characterisation Studies (all photos are to approximately the same scale)	8
Figure 5: Laboratory- Scale Roller Compactor used in 2010 (Man et al. 2011) and 2011 Pellet Manufacturing Trials.....	8
Figure 6: Thermal Conductivity as a Function of Poured Dry Density Pellets	10
Figure 7: Rebar Shaker used to Aid in Pellet Fill Densification. The vibrating component is shown attached to a rebar in this photograph.	11
Figure 8: Fine-grained (30 mesh) Wyoming Bentonite Granules used as Space-Filler in a Gap Fill Installation Trial using HCB Pellets Produced from MX-80-2001 Bentonite (Martino and Dixon 2007).....	12
Figure 9: Thermal Conductivity Testing on Pucks of Compacted Bentonite (a) Pre-Compacted Specimen Pucks, (b) Sample Frame and Thermal Properties Analyzer, (c) Sensor Installed in Specimen Frame, (d) Specimen Pucks Installed on either side of Sensor in a Two-Sided Test Configuration.....	15

Figure 10: Measuring Thermal Conductivity of Pellet Fill using a One-sided Test Configuration.....	15
Figure 11: Thermal Conductivity as a Function of Degree of Saturation for Solid Masses of 100% Bentonite; 50:50 and 60:40 Bentonite:Silica Sand Mixtures (Note S_r = Degree of Saturation).....	16
Figure 12: Thermal Conductivity of Solid Pucks of Material as a Function of Degree of Saturation for a Variety of Bentonite-additive Mixtures, Compared to 100% Bentonite at a Constant Dry Density of 1.8 Mg/m^3	17
Figure 13: Pellet Making Machine Showing Rollers.....	29
Figure 14: Sizes of Moulds used in Making Pellets.....	29
Figure 15: Colour Difference Between a Stock Mixture and Finished Pellets.....	30
Figure 16: Examples of Pellets Produced for Pellet Optimisation Study.....	32
Figure 17: Visual Appearance of Large Pellets Exhibiting Surface Defects.....	33
Figure 18: Device used to Determine the Crush Strength of Pellets.....	34
Figure 19: Bulk Density Tests using Different Poured Geometries.....	35
Figure 20: Large Pellet Pouring Test Frame at VTT.....	36
Figure 21: Abrasion Testing Equipment and Example of Results of Abrasion Testing of Clay Pellets.....	37
Figure 22: Test Chamber (upper) and Artificial Wetting of Pellet Fill in the IFB Geometry (lower).....	40
Figure 23: Types of Defects Observed in Pellets (most resulting from moisture content of feed material).....	41
Figure 24: Microscopic Images of Large Pellets showing Nature of Surface Defects.....	42
Figure 25: Effects of Clay Type and Pellet Size on Dry Density and EMDD.....	47
Figure 26: Effects of Pellet Composition Dry Density and EMDD of Wyoming Bentonite-Based Pellets.....	48
Figure 27: Free Swell Capacity of Bentonite Clay Pellets and Effect of Solution Salinity.....	49
Figure 28: Free Swell Index of Wyoming Bentonite and Blends with Crushed Illitic Shale and Fine Silica Sand.....	51
Figure 29: Changes in Swelling Pressures in Bentonite Clays as Result of Water Salinity (EMDD of as-placed clay-only pellet fill $\sim 0.6\text{-}0.95 \text{ Mg/m}^3$).....	52
Figure 30: Comparison of Average Crush Strength for Large, Clay-Only Pellets.....	53
Figure 31: Comparison of Average Crush Strength for Small, Clay-Only Pellets.....	53
Figure 32: Crush Strength in Newtons (N) of (a) Large, (b) Medium and (c) Small Pellets, showing Standard Deviation of Measurements.....	56
Figure 33: Comparison of Crush Strengths of (a) Large, (b) Medium, and (c) Small, Clay and Clay – Filler Pellets (Note: the average dry density (ρ_d) of the pellets are provided in the legend of each graph).....	57
Figure 34: Poured and Vibrated Density of Various Clay-Only Pellets. (Note: two different individual dry densities (1.8 and 1.9 Mg/m^3) for Milos AC200 small pellets).....	59
Figure 35: Poured and Vibrated Dry Bulk Densities of Pellets. (Note: two different individual dry densities (1.8 and 1.9 Mg/m^3) for Milos AC200 small pellets).....	61
Figure 36: Results of VTT Tests to Determine Loose, As-poured Density of Pellets Installed in a Narrow Gap.....	61
Figure 37: Comparison of Poured Dry Density Achieved in Small-Scale (AECL) and Large-Scale (VTT) Trials.....	64
Figure 38: Relationship between Abrasion Resistance (Mass Loss) and Crush Strength.....	66
Figure 39: Comparison of Thermal Conductivity Values for Different Sizes and Compositions of Pellets.....	71

1. BACKGROUND

Pellets manufactured from bentonite clay have several applications in the placement geometries considered by NWMO, Posiva and SKB. They can be placed immediately adjacent to the Used Fuel Container (UFC), filling the perimeter gap between the rock and the buffer; so that they fill large voids as part of the backfilling process and; as the main component in tunnel filling. Each of these applications is briefly described below.

Gap Fill in Placement Boreholes

Clay pellets are being considered for two primary applications in association with the buffer component of the repository sealing system. These applications involve being used in the KBS-3V being proposed by Posiva-SKB, and NWMO's In-Floor Borehole (IFB). The exact dimensions of these gaps vary depending on the specific placement geometry but in the NWMO concept these pellets may be used to:

1. Fill the inner gap between used fuel containers (NWMO terminology) / canisters (SKB, Posiva terminology) and highly compacted bentonite (HCB) rings. This dimension may be between 10 mm and 50 mm depending on the final geometry selected.
2. Fill the outer gap between the HCB buffer rings and the rock wall of the borehole. This gap fill material must be placed uniformly in a gap approximately 50-60 mm wide. Gap fill material will be expected to improve transfer of heat from the canister to the surrounding materials (relative to an unfilled annular gap) and prevent the adjacent HCB from experiencing excessive decrease in density as it swells into this region.

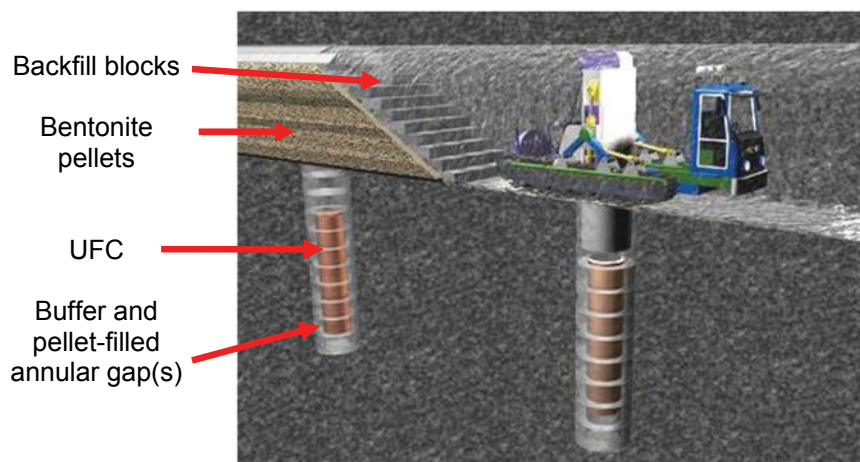

Figure 1: Vertical Container Placement Geometry (after TKS 2009) being considered by NWMO (In-floor borehole (IFB)), SKB (KBS-3V), and Posiva. The container, a bentonite buffer surrounding the canister and the materials used for backfilling the deposition tunnels are shown

Tunnel Backfill

A second region where clay pellets are proposed for use is as part of the tunnel backfill (Figure 1). In the reference concepts for SKB and Posiva backfilling, many regions of a repository will be backfilled using precompacted blocks of clay or clay-aggregate (filling the

majority of the tunnel volume), with clay pellets used to fill the remaining volume. The pellet-filled void is nominally 150 mm to 200 mm wide but actual gap dimensions will vary depending on the tunnel dimensions achieved during its excavation.

The backfilling pellets need to be placed efficiently (relatively large volumes in short time), uniformly and to a density that will ensure that the total sealing system maintains the specified hydraulic and mechanical properties once water saturation and swelling-induced density equilibration of the backfill is achieved. Pellets used in backfilling will also need to be able to protect the other components of the sealing system (e.g., buffer, backfill blocks or in situ compacted materials) from the erosive effects of inflowing groundwater and if possible it should also provide a medium that will allow for uniform wetting of the system.

Materials installed in these two regions of the KBS-3V geometry do not have the same size and thermal conductivity constraints due to the differences in the basic functions. In the buffer-filled borehole, pellets are intended to aid in heat conduction from the container to the surrounding rock mass and ensure the isolation function of the adjacent buffer is maintained. Pellets installed in the tunnels associated with the repository are primarily intended to provide: (1) physical protection to the backfill blocks; (2) aid in producing a backfill that will resist extrusion of the buffer from the adjacent boreholes, (3) a means of providing some short-term water retention (delaying water movement along a newly backfilled tunnel) and (4) ensuring that the longer-term sealing properties of the overall tunnel backfill meet the requirements set for it.

Horizontal Tunnel Placement Geometry

NWMO is considering placement geometries other than the IFB, particularly for a repository that is located in a sedimentary environment. For a sedimentary environment, the reference placement geometry for the used fuel containers (UFCs) is known as the Horizontal Tunnel Placement (HTP) option. In this geometry the UFCs are installed on their side in a circular tunnel (Figure 2). In contrast to the IFB, pellets will be the primary filling material adjacent to the UFC and so needs to have substantial thermal conduction capability as well as hydraulic and mechanical properties more in line with a buffer material.

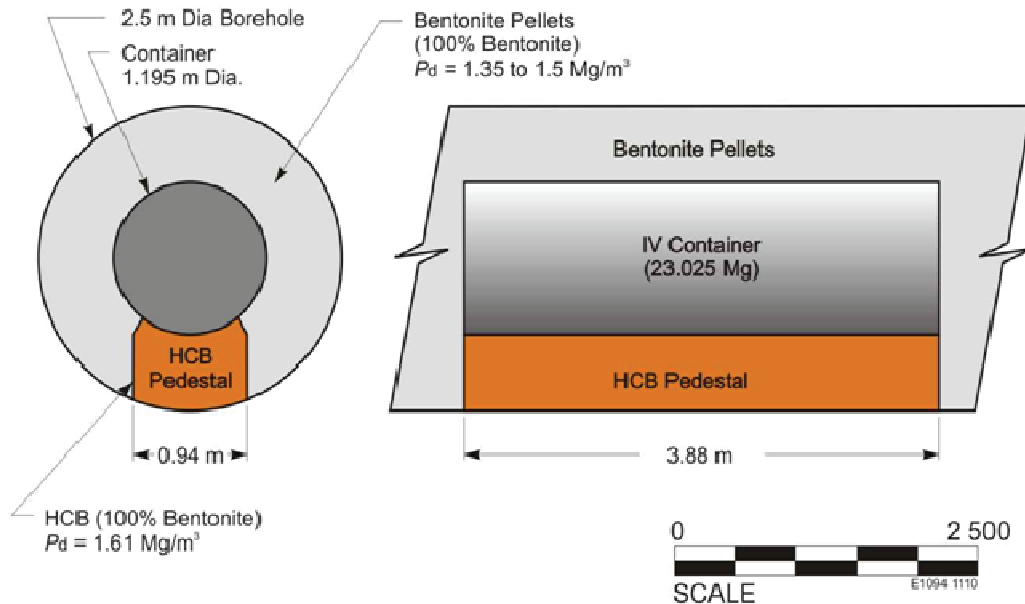

Figure 2: Horizontal Tunnel Placement (HTP) Geometry considered by NWMO

2. OBJECTIVES OF STUDY

NWMO, SKB and Posiva are considering variations of the KBS-3V geometry. Bentonite-based pellet materials are being considered as a component in the above-described repository sealing applications. A few differences exist between the requirements identified for pellet materials in these repository concepts (Table 1).

Most of the work done on the behaviour and characteristics of pellet materials prior to this study focused on commercially available roller compacted or extruded bentonite pellets (Dixon and Keto 2008, Marjavaara and Kivikoski 2011, Dixon et al. 2011b). However, depending on the specific application and geometry considered, the use of a bentonite-only material in manufacturing the pellets may not be necessary or desirable. Materials ranging from HCB pellets to various compositions of HCB pellets, crushed bentonite, extruded bentonite and admixtures with non-clay materials can be manufactured and used in a repository. There has not however been a focussed effort to evaluate potential optimization that would improve pellet performance and compatibility with adjacent materials as well as providing improved short- or long-term resistance to water movement/clay erosion.

Table 1: Gap Fill in IFB and HTP Geometries: Parameters and Properties of Primary Interest

Parameter	NWMO (IFB)	NWMO (HTP)	SKB (IFB)	Posiva (IFB)
Pellet Density	– Optimise to suit buffer Ps and TC requirements	– Optimise for Ps and TC	– Optimise to suit buffer Ps and TC requirements	– Optimise to suit buffer Ps and TC requirements
Pellet Size	– Optimise for inner and outer annular gaps in borehole – Optimise for backfill placement	– Optimise for tunnel filling	– Optimise for buffer-rock gap – Optimise for backfill placement	– Optimise for buffer-rock gaps – Optimise for backfill placement
Installed Density	– Optimise to ensure buffer performance requirements met	– Maximise	– Optimise to ensure buffer performance requirements met	– Optimise to ensure buffer performance requirements met
Thermal Conductivity	– Maximise while maintaining other properties	– Maximise while maintaining other properties	– Maximise while maintaining other properties	– Maximise while maintaining other properties
Pellet Durability	– Erosion resistant – Mechanical stability	– Erosion resistant – Mechanical stability	– Erosion resistant – Mechanical stability	– Erosion resistant – Mechanical stability
Pellet Composition	– HCB – HCB + filler?	– HCB – HCB + filler?	– HCB-buffer – HCB-blend – Low quality bentonite – Backfill clay	– HCB-buffer – HCB-blend – Low quality bentonite – Backfill clay

Note: Ps = swelling pressure
TC = thermal conductivity

The work reported on in this document has focussed on pellet materials generated using mechanical roller compaction technologies. This technology produces round, oblong or lozenge shapes depending on the design of the dies used in the compaction machinery. Preliminary work done to evaluate options for improving pellets through blending of more conductive materials with the bentonite prior to pellet manufacture and the potential to improve the individual pellet densities was completed for NWMO in 2010. Some of these results were presented by Man et al. (2011) and are briefly summarised in Section 3. These data were also used in developing the work plan for the current project.

Pellets can also be produced as rod-shaped products of fixed cross-section but varying length using extrusion technologies. The production, performance and characterisation of these extruded materials are the subject of a complimentary study being undertaken by Posiva. This work is in progress and should be published as a Posiva Working Report in 2013.

Trial pellets are also being produced and tested by SKB. Pellets being considered include extruded pellets and pressed (6 mm diameter) pellets made from bentonite sourced from IBECO and Asha. Their testing program includes erosion testing, water storage capacity, and installation trials to evaluate durability. The results of this work will be reported in 2012.

The manufacturing and testing program documented below has produced and tested a variety of clay-based pellet materials with the goal of identifying if a process of optimizing size, shape, water content, density and composition of pellets for both gap fill and backfill applications will yield substantial improvement in system behaviour. The project builds on work conducted by AECL for NWMO in 2005 (Dixon et al. 2005) and 2010 (Man et al. 2011), which is summarised in Section 3. The methods used in pellet production and evaluations are described in Section 4 while the results are presented in Section 5.

Specific questions that have been addressed in the current study are:

- What additives (in what proportions) can be included to increase the thermal conductivity of as-placed pellet materials without sacrificing adequate swelling and hydraulic behaviour?
- What does varying pellet composition and water content have on their strength?
- What are the properties of pellets made from bentonites of differing sources?
- What are the benefits of rolled pellets versus extruded pellets (if any)?

3. PREVIOUSLY COMPLETED PELLET DEVELOPMENT STUDIES

3.1 BACKGROUND

Work to evaluate the basic characteristics of pellet fill materials have been documented in several reports (Dixon et al. 2005, Dixon and Keto 2008, Dixon et al. 2011b, Hansen et al. 2009, Man et al. 2011, Marjavaara and Kivikoski 2011). The information contained in these documents was used in developing the scope of work covered in the current study.

In the IFB geometry, the presence of pellet fill acts to improve the thermal conduction of the buffer-filled borehole by providing a physical bridge through which heat can flow, as opposed to having only an insulating air gap. The importance of this fill material can be seen if the placement geometries, buffer density and conditions developed in the course of system equilibration for the various IFB geometries are considered. For example:

- NWMO's IFB geometry calls for a uniform as-placed dry density of 1.61 Mg/m^3 (at 65% initial degree of saturation) for the highly compacted bentonite (HCB) in the volume surrounding the used fuel container (excluding annular gaps). This HCB will have an initial thermal conductivity of $\sim 1 \text{ W/(m}\cdot\text{K)}$ as discussed in Section 3.3. Following container installation, the regions closest to the heat-generating UFC can be expected to desiccate to some degree and in a dry borehole condition, the thermal conductivity of the intact buffer can therefore be expected to decrease to $\sim 0.5 \text{ W/(m}\cdot\text{K)}$ or less (Man et al. 2011). If left unfilled, the adjacent air-filled gap will only have a thermal conductivity in the order of $0.024 \text{ W/(m}\cdot\text{K)}$. Any loss of dry density (e.g., partial swelling, cracking, erosion) will further reduce the overall thermal conductivity of the region surrounding the UFC. On completion of HCB hydration and swelling to fill the entire IFB volume not occupied by the UFC (assuming no pellets were installed in the inner or outer gaps), the system will reach an equilibrated dry density of approximately 1.6 Mg/m^3 . This corresponds to a material having an average thermal conductivity of $\sim 0.7 \text{ W/(m}\cdot\text{K)}$ after swelling. Pellets installed in the gaps between the HCB and the adjacent rock/UFC will provide a thermal bridge allowing better heat transfer away from the UFC. These pellets will also result in a higher equilibrated dry density of the IFB clay fill and a higher thermal conductivity of the buffer over the long-term. Hence the consideration for filling the gap between the UFC and HCB rings in NWMO's, SKB's and Posiva's concepts.
- In Posiva's Detailed Design of the IFB concept, the HCB is targeted to have an average buffer dry density 1.60 Mg/m^3 at 100% saturation (26.5% gravimetric moisture content at saturation, void ratio = 0.72) on achieving density equilibration (Juvankoski 2011). It should be noted that Posiva's design calls for differences to exist in the original densities of the HCB, depending on the location within the borehole. The disks located above and below the container are to be 1.99 Mg/m^3 dry density (75% initial degree of water saturation), while the rings surrounding the container are to be 2.05 Mg/m^3 at 82% initial degree of saturation. The pellets placed in the outer gap are defined to be 1.075 Mg/m^3 dry density at 24% saturation.

The net result of the use of pellets to fill the gap(s) present in the IFB is an improved equilibrated density for the materials surrounding the UFC. The degree to which improving or modifying the density (or thermal characteristics) of the pellets is possible and how this will affect the thermal conductivity of the buffer surrounding the UFC has not yet been assessed and is the topic of the study described in Section 4 and 5 of this document.

Prior to initiation of the work described in this report, a study whose primary focus was to evaluate compositional options for pellets to be used in both gap filling in the IFB and the HTP geometries being evaluated by NWMO was completed (Man et al. 2011). Maximizing the density to which pellet fill can be placed as part of the backfilling process is also a goal that is covered by this pellet optimisation study. For the purposes of background documentation and to put into context the work done in 2011 as NWMO's contribution to a joint research project with Posiva and SKB, some of the key results of previous pellet studies are presented below.

The 2010 study included preliminary evaluations of the potential means of manufacturing pellet materials with superior thermal conduction characteristics. This was done by examining the effects of blending bentonite clay with other, more thermally conductive materials and then evaluating their thermal conduction characteristics. The results of this study were presented by Man et al. (2011) and were used in developing the pellet optimisation work initiated by NWMO, SKB and Posiva in 2011 (Sections 4 and 5).

To begin the process of determining what the key parameters affecting UFC spacing in the HTP geometry, a numerical model of the HTP method was constructed for the purpose of estimating the influence of thermal conductivity of the engineered clay barrier. It should be noted that this is only a hypothetical model to illustrate the influence of parameters, and some of the values are not necessarily in accordance with NWMO, SKB and Posiva programs. The results of the modelling exercise are provided in Figure 3. For a maximum surface temperature at a UFC of 125°C, a thermal conductivity of 0.5 W/(m·K), will require a spacing of approximately 17 m. If the thermal conductivity of the engineered clay barrier can be increased into the range of 0.7 W/(m·K) to 0.9 W/(m·K), the required spacing for the HTP concept could be reduced to approximately 16 m and 14 m, respectively.

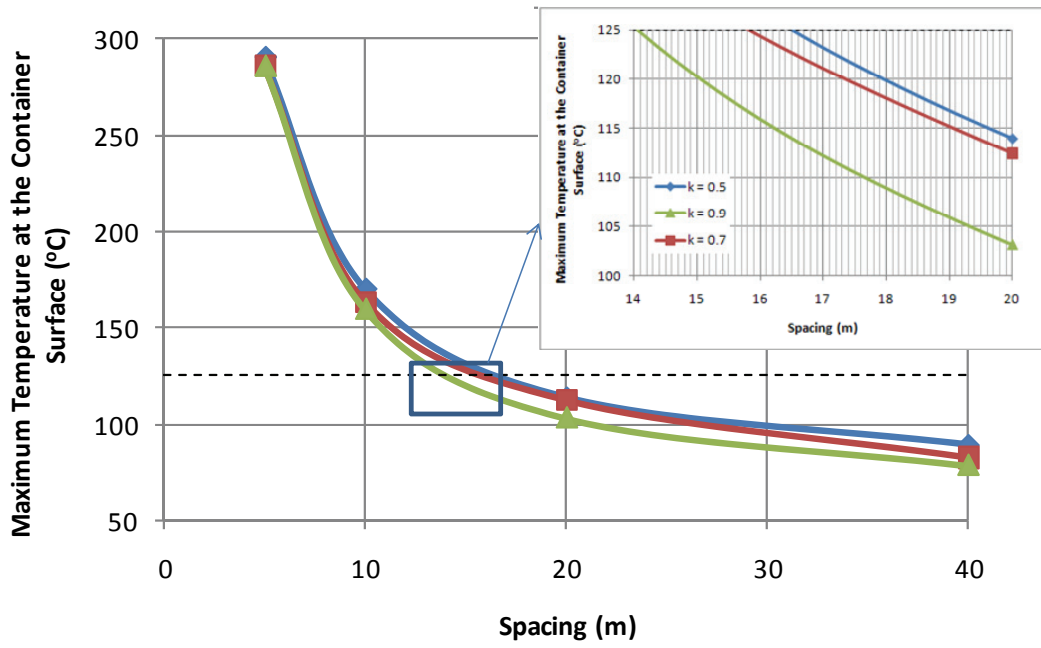

Figure 3: Results of an Illustrative Model showing the Effect of Thermal Conductivity of the Engineered Clay Barrier in the HTP Method on the Required Tunnel Spacing to Prevent Excessive Heat Build-Up

None of the pellet or pellet granule materials evaluated in the 2010 study achieved a thermal conductivity greater than 0.7 W/(m·K) (Section 3.2.4). Although a reduction in container spacing from 17 to 14 m may appear small, when factored over the total number of UFCs in the NWMO repository, a significant reduction in total tunnelling length and repository area may be realized. This needs to be compared to the effort and cost of placing tunnel fill at greater densities in a radiological environment.

3.2 IMPROVING AS-PLACED DENSITY OF PELLET FILL: NWMO'S 2010 PELLET STUDY

3.2.1 Pellet Materials Examined

The NWMO-sponsored evaluation of commercially-available bentonite pellets began with determining the effects of pellet size, shape and density on the placement density of pellet fill in the HTP geometry, specifically, their mechanical and thermal characteristics (Man et al. 2011). The commercial bentonite pellets tested included ~9 mm- and ~13-mm-diameter cylindrical, oblong shaped pellets of the type examined by Dixon et al. 2005 and subsequently by Man et al. (2011); square-shaped pellets and extruded (Cebogel) pellets as shown in Figure 4. While focused on HTP application, much of the information generated has application to materials and methods for placement of pellet fill in the IFB annular spaces and the gap between backfill blocks and the surrounding geosphere.

The commercially-sourced materials were compared to pellets produced at AECL's Geotechnical Laboratory using a laboratory-scale roller compactor (Figure 5). This device allowed for production of materials using a range of compressive forces, water contents and physical compositions. This machine could make two sizes of pellets by using interchangeable rollers. The smaller rollers produced pellets of 10 mm width and 23 mm in length, and larger rollers pellets of 20 mm of width and 40 mm in length as shown in Figure 4. Both of these pellet types were ~10 mm thick.

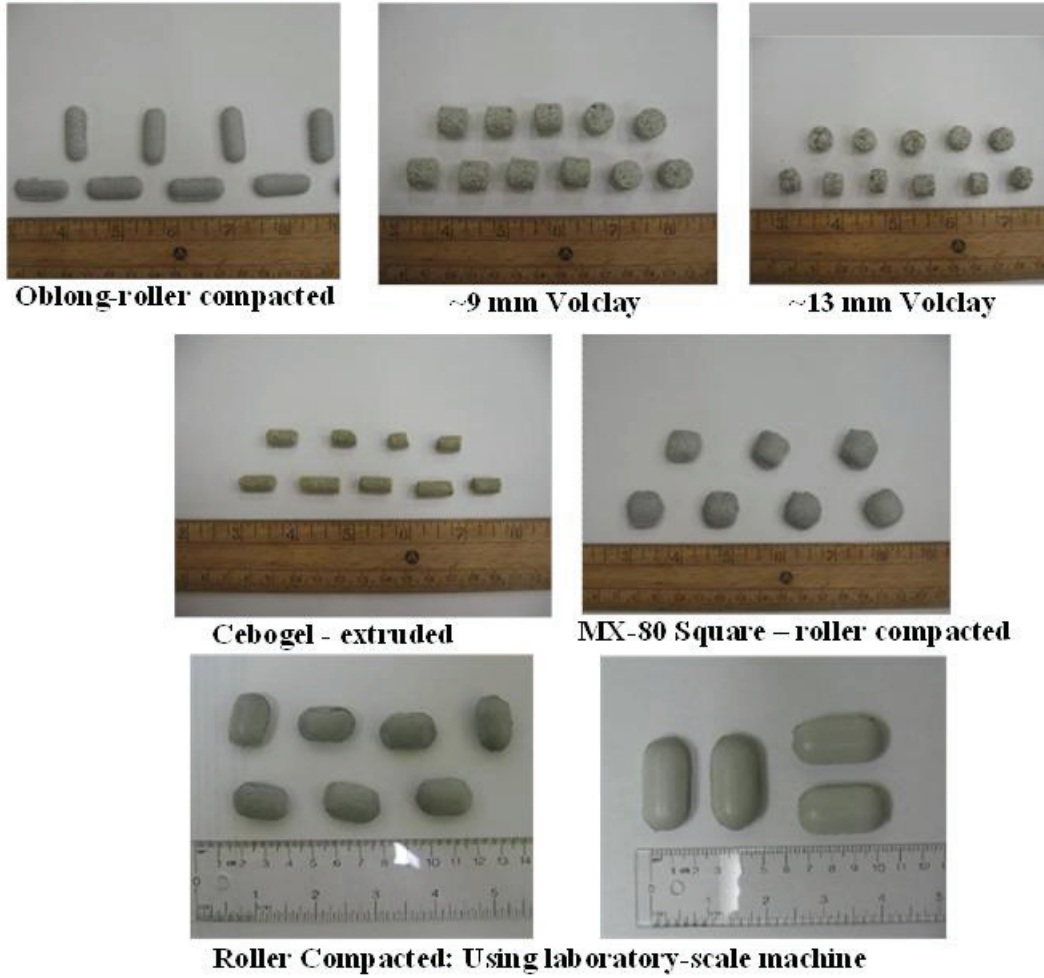

Figure 4: Pellets Examined by Dixon et al. (2005) and Man et al. (2011) Pellet Characterisation Studies (all photos are to approximately the same scale)



Figure 5: Laboratory- Scale Roller Compactor used in 2010 (Man et al. 2011) and 2011 Pellet Manufacturing Trials

3.2.2 Pellet Manufacturing Trials

The production of bentonite pellets using roller compaction allows for variation of several parameters during the manufacturing process. Trials for manufacturing pellets from bentonite clay were done to establish the factors controlling the density achieved (e.g., changing feeding rates, roller speeds and compression pressures (force with which rollers are kept in contact), water content of the feed material), type of feed material. Additionally, the use of recycled materials (pellets that are crushed and fed back into the compactor) was evaluated to determine if an initially denser feed material resulted in improved pellet densities.

Table 2 shows a comparison of the lab-manufactured bentonite pellets produced using a 200-mesh Wyoming bentonite (BC-NSB-200-2008), under three compression pressures. The bentonite pellets listed as “Recycled” were produced by roller-compacting crushed bentonite pellets produced in the first compaction cycle. The crushing of the pellets to fine-grained feed for a second compaction cycle was done to evaluate what effect using a higher-density source material would have on the pellets.

Table 2: Pellets Produced using Different Compression Pressures

Compression Pressure (MPa)	~10 (1450 psi)		~12 (1800 psi)		10.3 (1500 psi)
	Single cycle	Recycled pellets	Single cycle	Recycled pellets	Single cycle
Bulk Density (Mg/m ³)	2.12	2.15	2.13	2.17	2.14
Dry Density (Mg/m ³)	1.95	1.98	1.96	2.00	1.97
Grav. Water Content (%)	9.11	8.71	8.58	8.63	8.76

It was found that there was little difference in achievable density for compression pressure of ~10 MPa (1450 psi) and ~12 MPa (1800 psi) as shown in Table 2. A compression pressure of ~10.3 MPa (1500 psi) was therefore chosen for use in producing pellets in this study. The production rate of the machine under this pressure was about ~2 kg pellets per minute. The roller compression process generates considerable heat, resulting in water content decrease of pellets, a factor that needed to be taken into account with respect to ensuring that the pellets retained their physical integrity once they had cooled.

Table 3 presents a summary of the as-placed properties of the various pellet materials examined in the 2010 study (Man et al. 2011). These data show that the laboratory-produced pellets have higher dry density than commercially available bentonite pellets (1.90 Mg/m³ versus 1.7-1.8 Mg/m³) and higher as-placed bulk thermal conductivities at different densities (0.48 and 0.56 W/(m·K) at loose and shaken conditions, respectively, Figure 6). Even with the improved density and thermal properties achieved using denser pellets (and addition of fines to fill inter-pellet gaps), the thermal conductivity of these materials were below 0.7 W/(m·K) (Section 3.2.4).

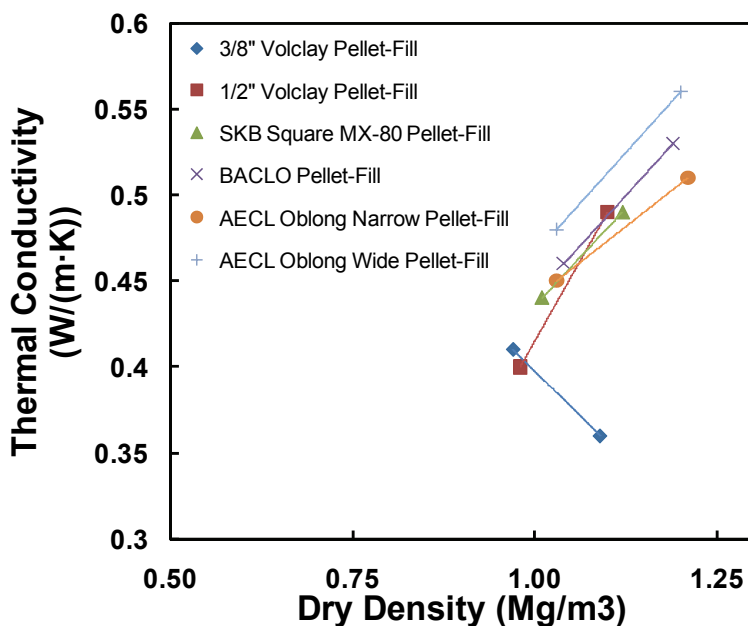

Figure 6: Thermal Conductivity as a Function of Poured Dry Density Pellets

Table 3: Comparison of Densification Achieved Using Commercially Available and Specially-Manufactured Pellets (after Man et al. 2011)

	3/8" Volclay	1/2" Volclay	Square	BACLO ⁺⁺ Cebogel	Oblong BC-NSB-200-2005/8 (26x10x5 mm)	1/3-Scale Mockup BC-NSB-200-2008 (22x14x10 mm)
Bulk Density of each pellet (Mg/m ³)	1.86	1.82	1.92	2.10	2.14	2.11 (1.90 ⁺)
Dry Density of each pellet (Mg/m ³)	1.72	1.67	1.81	1.83	1.96	1.90 (1.71 ⁺)
As-Placed Bulk Density (Mg/m ³)*	1.05	1.07	1.08	1.13	1.12	1.12
As-Placed Dry Density (Mg/m ³)*	0.97	0.98	1.01	1.04	1.03	1.03
Bulk Density by Shaker (Mg/m ³)*	1.18	1.20	1.21	1.30	1.32	1.30
Dry Density by Shaker (Mg/m ³)*	1.09	1.10	1.12	1.19	1.21	1.20
Bulk Density by Vibrator (Mg/m ³)*	-	-	-	-	-	1.22 (1.43 ^{**})
Dry Density by Vibrator (Mg/m ³)*	-	-	-	-	-	1.12 (1.31 ^{**})
Thermal Conductivity (W/(m·K)) (as-placed condition)	0.41	0.40	0.44	0.46	0.45	0.48
Thermal Conductivity (W/(m·K)) (shaken condition)	0.36	0.49	0.49	0.53	0.51	0.56

* - maximum practically-achievable density using pellet-only fill, ** - achievable dry density using a modified probe in a mock-up trial and included addition of 80-mesh bentonite fines to pellets to fill large inter-pellet voids, ⁺ - Large size pellets; ⁺⁺ Extruded bentonite rod-shaped pellets used as gap fill in tunnel backfilling trials (Dixon et al. 2008a,b; 2011).

3.2.3 Densification of Pellet Fill

Two compaction techniques (electric shaker and needle-type concrete vibrator), were examined in an effort to develop a practical means of densifying a large volume of pellet fill. Pellets were subjected to a shaking agitation and this produced a higher as-placed dry bulk density (1.20 Mg/m^3) than was achieved using a modified small concrete vibrator (1.12 Mg/m^3) (Table 3). Despite achieving a higher as-placed density using a shaker, the shaker-type densification does not readily transfer to a full-scale tunnel placement or installing pellets into the annular spaces of the IFB. The vibrating technique was therefore deemed to be more representative of what can be achieved in a field application. The vibratory technique was subsequently further developed by use of a concrete rebar vibrator (Figure 7) rather than a vibrating concrete probe and this modified technique was used in the installation of a 1/3-scale HTP mock-up. In the 1/3-scale HTP mock-up, rebar lengths were installed horizontally in the volume of pellets to be backfilled and the pellets were vibrated in layers as the mock-up was installed. This technique is described further in Section 3.2.4 and a visual example of the results of this process is presented in Figure 8. This modified technique improved the densification of the pellet and granule mass to 1.31 Mg/m^3 , as-placed dry density. This was slightly lower than the target dry density of 1.41 Mg/m^3 (needed to provide the desired thermal conductivity for the HTP fill).



Figure 7: Rebar Shaker used to Aid in Pellet Fill Densification. The vibrating component is shown attached to a rebar in this photograph

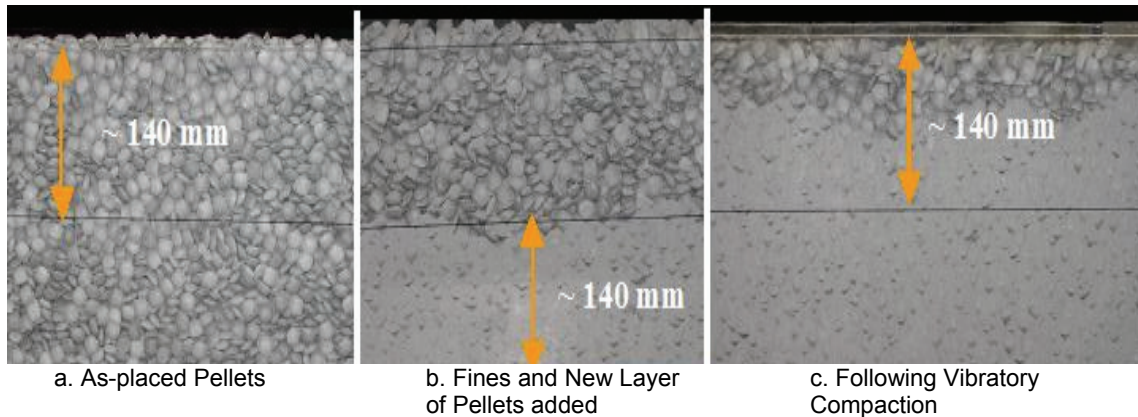

Figure 8: Fine-grained (30 mesh) Wyoming Bentonite Granules used as Space-Filler in a Gap Fill Installation Trial using HCB Pellets Produced from MX-80-2001 Bentonite (Martino and Dixon 2007)

3.2.4 Development of Pellet-Granulate Blends to Improve As-placed Density and Thermal Conductivity

As noted above, in order to maintain the thermal conduction needed to limit temperatures at the container surface to acceptable levels and reduce the container spacing needed in the HTP geometry, the as-placed dry density of bentonite-only fill material needs to exceed $\sim 1.41 \text{ Mg/m}^3$. To accomplish this some means of filling the spaces between the pellets to improve thermal conductivity is required. The thermal conductivity of the poured pellet-fill material was less than $0.5 \text{ W/(m}\cdot\text{K)}$ for all of the tested pellets. Light compaction increased the thermal conductivity of the pellet-fill material to a maximum of $0.56 \text{ W/(m}\cdot\text{K)}$ for the wide pill-shaped pellets made by AECL (Section 3.3).

To evaluate the possibility of further increasing the as-placed density and thermal conductivity, a needle-type concrete vibrator was used in a limited set of trials for the AECL wide oblong pellets. The vibrating technique is representative of what might be achievable at full-scale and a dry bulk density of 1.3 Mg/m^3 was achieved using this device. While an improvement in as-placed density, the results indicate that a single-size pellet material will not be able to be densified sufficiently to reliably achieve the desired thermal conductivity for use in the HTP geometry. This leaves three additional possible approaches to modifying the pellet fill so that it achieves the desired thermal characteristics:

- (1) Using a graded pellet – fines material that provides better packing density,
- (2) Improving the thermal characteristics of the pellets through compositional adjustment of the pellets themselves (Sections 3.3, 4 and 5), and
- (3) Applying a combination of approaches 1 and 2.

In the studies undertaken in 2005 (Dixon et al. 2005) and 2010, Man et al. (2011), approach (2) above was evaluated by using granules of bentonite (MX-80 bentonite (nominally an 80-mesh size)) in conjunction with single-sized pellets and vibratory densification. Pellets were installed in layers, followed by pouring sufficient MX-80 fines on the top of the pellet layers. In a dry environment these fines will flow through the pellets and fill the open pore spaces when vibrated. This placement technique was used by Dixon (2005). In that study, the pellet-fine grained bentonite ratio was 70:30 (pillow-shaped pellets) and 80:20 (elongated pellets) by mass

and as-placed dry densities in the order of 1.42 to 1.46 Mg/m³ were achieved when a modified concrete pencil vibrator was used in the installation process to encourage fines movement and optimised pellet orientation.

3.3 CHARACTERISATION OF THERMAL PROPERTIES OF PELLET MATERIALS: 2010 NWMO PELLET OPTIMISATION STUDY

3.3.1 Thermal Conductivity Evaluation

Section 3.2 identified some of the potential limitations associated with tunnel fill in the HTP geometry, but also demonstrated that it was possible to place gap fill materials into the relatively confined spaces associated with the IFB geometry and tunnel backfilling. While thermal characteristics are less important in the backfill components of the repository sealing system, they do have an influence in regions close to the UFC. Means to improve the thermal conduction characteristics of pellet fill while not adversely affecting the other performance characteristics needed is an important goal (e.g., low hydraulic conductivity, high swelling pressure, resistance to erosion by flowing water).

The material used to manufacture gap fill and HCB-based buffer materials in the 2010 and 2011 studies is Wyoming bentonite clay (BC-NSB-200-2008: Bentonite Corporation-National Standard Bentonite, 200 mesh Wyoming-type bentonite). Testing to determine the effects of dry density and gravimetric water content have on the ability of bentonite-based materials to conduct heat was undertaken. In these tests solid “pucks” of bentonite-based material were compacted (dry densities of 1.0 to 1.8 Mg/m³) and tested using the thermal properties measurement device shown in Figure 10. As Highly Compacted Bentonite (HCB) will be located next to the container, an understanding of its thermal behaviour is critical, particularly since a period of thermally-induced desiccation is likely. These data also provide information on the thermal characteristics of individual pellets that would be used to fill gaps between the various elements of the sealing system.

3.3.2 Improving the Thermal Conductivity of Individual Pellets

Measurement of Thermal Conductivity

The first step in evaluating potential means of improving the thermal characteristics of pellet materials is to determine what effect additives will have on the properties of a single pellet. From this it is possible to evaluate what the effect might be on a mass of pellets. Thermal properties testing was undertaken using a Hot Disk Thermal Constants Analyzer¹ (Figure 9 and Figure 10). The system operates by supplying a pulse of constant heat to a sample sensor, which acts as both a heat source for increasing the temperature of the sample and a resistance thermometer to monitor the change in temperature after the heat pulse. Details of this technique are provided in Section 4.

Effects of Blending Materials

The scoping studies conducted in 2010 included evaluating a range of materials considered for use in the repository sealing system. This was in part to provide improved thermal data for the various components for use in future modelling exercises. As a result considerable information

¹ Hot Disk Constants Analyzer, TPS2500, manufactured by Hot Disk AB, Chalmers Science Park, Chalmers University of Technology, Sven Hultins gata 9 A, SE-412 88 Gothenberg, Sweden

not necessarily relevant to the development of gap fill or backfill pellets was developed. This information is not discussed in detail in this report. However these tests did provide some initial quantification related to the effects of composition and blending on the thermal characteristics of clay-based materials. From this it was possible to complete an initial assessment of the potential for improving the thermal characteristics of pellet fill.

Figure 11 shows the thermal conductivity data for a solid mass of 100% Wyoming bentonite as a function of degree of saturation. These data show that thermal conductivity of bentonite-only material increases with density and degree of saturation but only by a small amount. The range of thermal conductivity is only ~ 0.25 to ~ 1.0 W/(m·K). When sand is added to the bentonite prior to compaction of the mass, a dramatic increase in the system's thermal conductivity is evident.

The thermal conductivity data for 50:50 and 40:60 mixtures of bentonite and silica sand as a function of degree of saturation and dry density are also provided in Figure 11. These are materials that have been examined for use as a Bentonite Sand Buffer (BSB) rather than an HCB buffer in AECL's IFB concept in the 1990's as well as a component in a tunnel plug (Chandler et al. 2005, Martino et al. 2008) and shaft seals (Martino et al. 2011, Dixon et al. 2011c). Although the grain-size of the sand component used in these materials is larger than could be used in pellet manufacturing, these data provide valuable insight into what most affects thermal conductivity in bentonite-based materials and are likely representative of the behaviour of larger masses of material.

In Figure 11, the thermal conductivity measurement of a 40:60 mixture of bentonite and granitic sand shows the effect of different types of filler sand on thermal conductivity of bentonite sand mixtures (BSB contained silica sand while the ESP backfill was produced from sand originating from granitic rock). Although the aggregate component was higher (60 versus 50%), at similar dry densities the bentonite-granitic sand mixture has a lower thermal conductivity. This is attributed to the feldspar fraction in the granitic sand, which has a lower specific gravity and thermal conductivity (~ 2 W/(m·K)) than quartz (~ 3 W/(m·K)).

The low thermal conductivities measured for HCB (at low degrees of saturation) and blends of bentonite and sand or granite aggregate shown in Figure 11, particularly under low degree of water saturation led to an investigation of the effects of other potentially compatible additives to bentonite. Specifically, a natural titanium dioxide (rutile) and copper powder were evaluated for their effect on the thermal conductivity of a bentonite-based mass. The results of those tests are shown in Figure 12. Improved thermal conductivity at low degrees of saturation (e.g., $< 40\%$), were observed for materials containing silt-sized silica sand or copper powder. It is important to note that it is at a low degree of saturation where improved thermal conductivity is needed. At a degree of saturation above $\sim 40\%$, the effect of increased moisture surpasses the effect of the copper powder, and copper-amended materials show thermal conductivity values approximately the same as those of 100% bentonite. Mixtures containing silica sand showed higher thermal conductivities than bentonite-only materials where the degree of saturation exceeded $\sim 60\%$ (Figure 12). The relative improvement of silica sand over copper powder for a given mass ratio is attributed to the smaller volume of copper relative to silica sand for a given mass ratio (specific gravity of copper vs. silica sand). The bentonite-silica sand blend would have a higher degree of sand-sand particle contact and hence better thermal conductivity

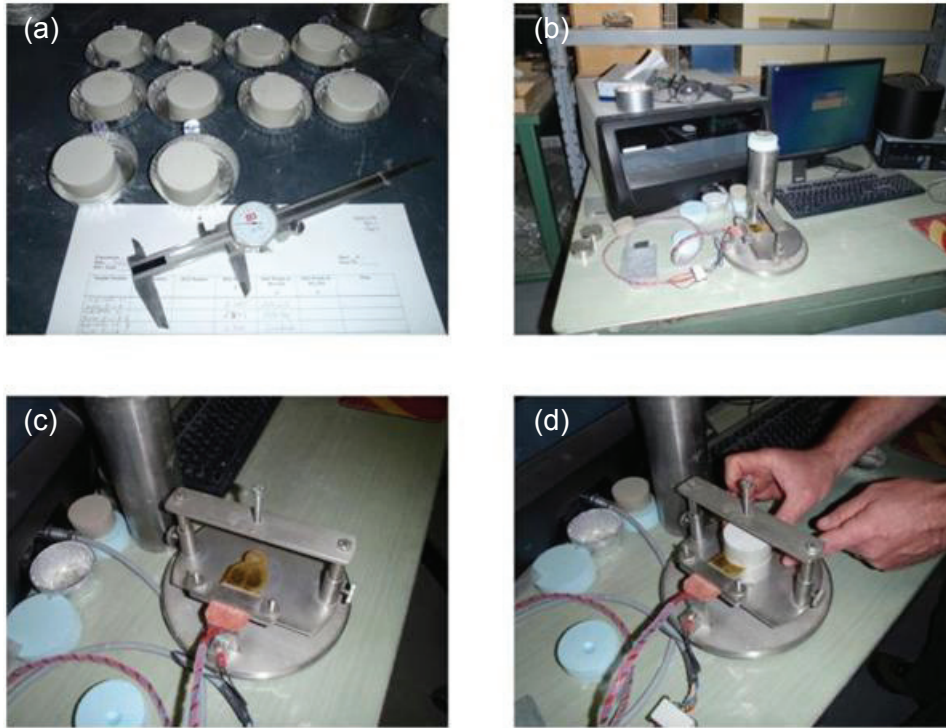
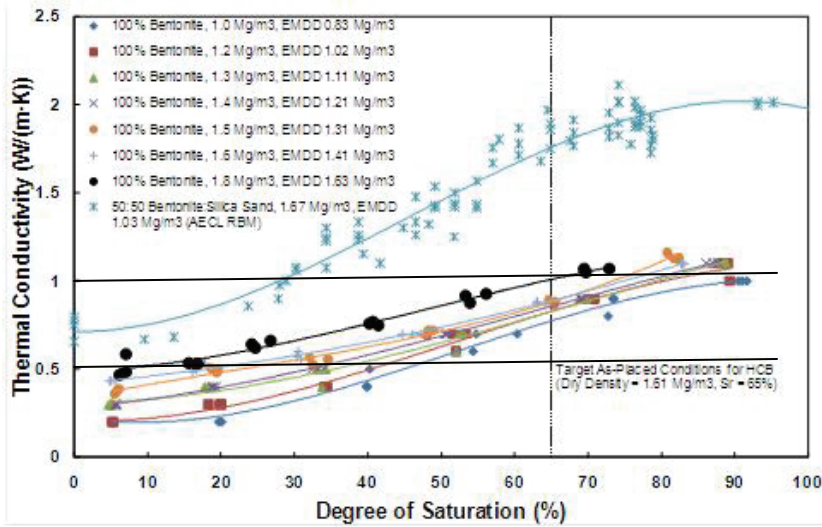

Figure 9: Thermal Conductivity Testing on Pucks of Compacted Bentonite (a) Pre-Compacted Specimen Pucks, (b) Sample Frame and Thermal Properties Analyzer, (c) Sensor Installed in Specimen Frame, (d) Specimen Pucks Installed on either side of Sensor in a Two-Sided Test Configuration



Figure 10: Measuring Thermal Conductivity of Pellet Fill using a One-sided Test Configuration



100 % Bentonite

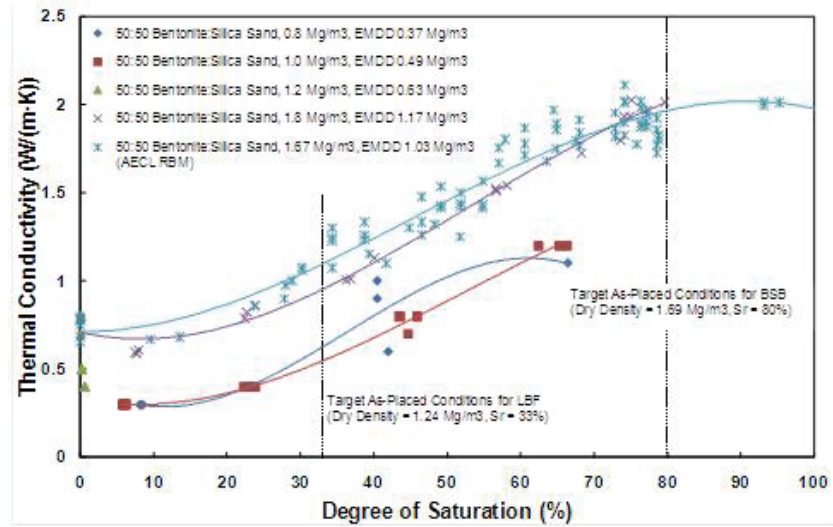

50:50 Bentonite : Sand

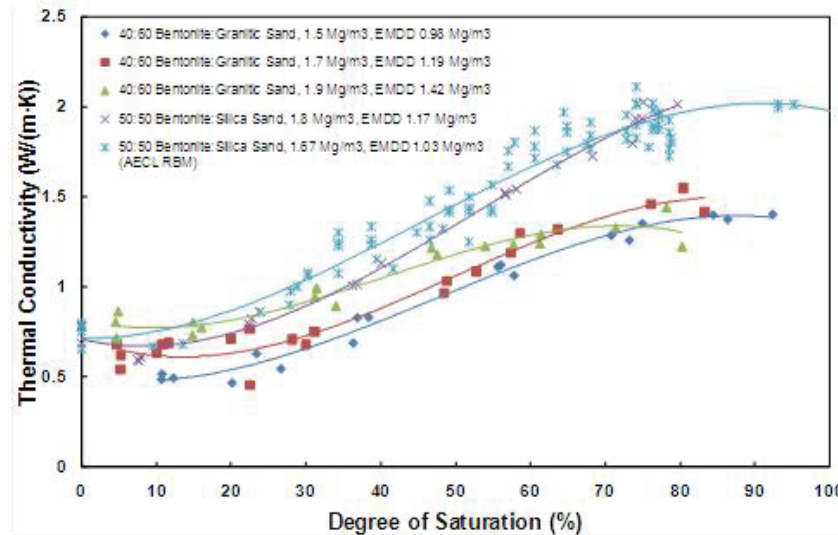

40:60 Bentonite : Sand

Figure 11: Thermal Conductivity as a Function of Degree of Saturation for Solid Masses of 100% Bentonite; 50:50 and 60:40 Bentonite:Silica Sand Mixtures (Note Sr = Degree of Saturation)

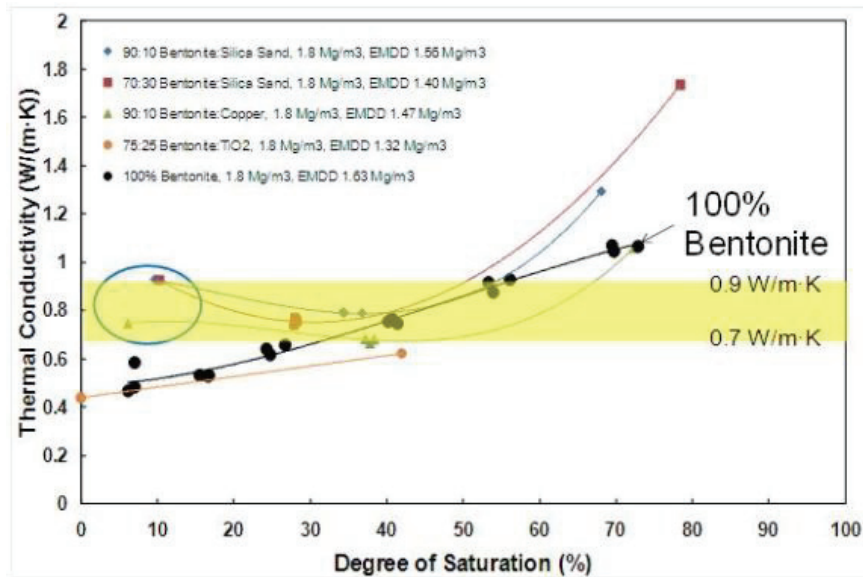

Figure 12: Thermal Conductivity of Solid Pucks of Material as a Function of Degree of Saturation for a Variety of Bentonite-additive Mixtures, Compared to 100% Bentonite at a Constant Dry Density of 1.8 Mg/m³

Beyond the thermally-related characteristics of bentonite-additive materials, the additives reduce the mass of bentonite per unit volume at a specific dry density, which in turn reduces the effective montmorillonite dry density (EMDD). EMDD is defined as:

$$EMDD = M_m / (V_m + V_v) \quad \text{or} \quad EMDD = (M_T * M) / (V_T - ((M_{nm}/G_{nm})))$$

Where M_m = dry mass of montmorillonite clay; V_m = volume of the montmorillonite minerals; and V_v = volume of voids, M_T is the total mass of the specimen, M is the montmorillonite content, M_{nm} is the mass of the non-montmorillonite component(s) and G_{nm} is the specific density of the non-montmorillonite component(s). Calculation of this parameter requires that the montmorillonite content be known. The non-montmorillonite component(s) must also be defined so that their volume can be removed from the calculation.

EMDD values, provided for each material in the plots, provide a means of estimating the swelling pressures and hydraulic conductivity of water-saturated materials. Swelling pressure increases and hydraulic conductivity decreases with increasing EMDD. These changes also need to be taken into account when evaluating the potential advantages of using a blended fill material.

Thermal Conductivity of Bentonite Pellets

Based on the result of the screening study to evaluate how thermal conductivity could be affected by use of additives such as copper and titanium dioxide, it was found that there was little improvement in the thermal characteristics of bentonite-based materials beyond what could be provided by more available and less expensive materials such as silica or granitic sand. Hence, no further evaluations were undertaken for copper or titanium dioxide with respect to

manufacturing of pellets. The 2010 pellet placement study therefore focussed on bentonite-only pellet materials and evaluating their thermal characteristics.

As presented in Sections 3.2 and 3.3 (Figure 6), six types of clay pellet-fill materials were screened during 2010 in order to evaluate their potential for use as gap-fill materials in locations where thermal conductivity is an important parameter. These included four commercially available pellets and two types of pellets developed by AECL. The commercially available bentonite pellets included 3/8" (~9-mm) and 1/2" (~13-mm) cylindrical pellets made of Volclay (Wyoming) bentonite, square-shaped pellets made of MX80-2008 Wyoming bentonite from SKB (16-mm long x 16-mm wide x 8-mm thick), and extruded pellets made of activated Milos bentonite (Cebogel-2010) from the BACLO ("BACkfilling and CLOsure of a deep repository" project conducted by SKB and Posiva).

3.4 SUMMARY OF RESULTS FROM 2010 STUDIES

Bentonite-based materials were prepared at a range of densities and saturations with distilled water and their thermal properties measured. The results indicate lower than desired thermal conductivities for engineered clay barriers that will be in close proximity to heat generating UFCs for the HTP geometry considered by NWMO. Specifically, the thermal conductivity of HCB at low saturations and pellet-fill material is close to 0.5 W/(m·K). This will result in the requirement for larger UFC spacing to prevent excessive temperatures at the surface of a given UFC. Increasing the thermal conductivity of these materials into the range of 0.7 W/(m·K) to 0.9 W/(m·K) will result in a decrease in UFC spacing in the order of up to 2.5 m. These relatively low thermal conductivities are not as critical where pellets are to be used to fill annular gap(s) present in the IFB geometry since the alternative is to leave an open (air) gap which is much less desirable thermally.

Preliminary work was conducted to examine the effect of adding various admixtures to HCB with the goal of increasing thermal conductivity. The addition of small amounts of silica sand and copper powder resulted in an increase in thermal conductivity to between 0.7 W/(m·K) to 0.9 W/(m·K). This occurred at low degrees of saturation, where the increase is needed most (i.e., during intense heating by UFCs and associated drying). However at higher degrees of saturation (>60%) copper-amended materials did not show thermal characteristics much improved from those of bentonite-only materials. Sand-amended bentonite showed a much improved thermal conductivity over bentonite-only materials for degree of water saturation >60%. It should be stressed that this increase in thermal conductivity was achieved using puck-shaped specimens of HCB-additive mixtures. Further testing of pellets with the added variable of inter-pellet porosity required further investigation.

The used bimodal mixtures of pellets and fine grained bentonite aggregates to fill the porosity between pellets and therefore increase density and thermal conductivity showed some promise. Previous work by Dixon et al. (2005) indicated that use of a 2-size material could improve the density achieved (1.42-1.46 Mg/m³ dry density achieved in laboratory tests) but this is only marginally acceptable with respect to thermal characteristics needed for the HTP, and not particularly feasible for the more constrained IFB geometry. This technique has also been examined by NAGRA in the form of a mixture of pellets, granules and fines as part of their HTP research (Volckaert 2000, De Bock et al. 2008). This technique achieved some improvement of the as-placed density (1.38 – 1.51 Mg/m³), but as with the 2010 study described above, this will provide a fill whose thermal conductivity is in the lower range of acceptability.

4. CURRENT (2011) STUDY

4.1 BACKGROUND

The objectives of the joint pellet optimization study supported by NWMO, Posiva and SKB during 2011 have been described in Section 2. The components of the 2011 study are largely extensions and refinements of the work completed in 2010 described in Section 3 and published, in-part by Man et al. (2011), as well as additional materials and scope associated with specific needs of SKB and Posiva.

The work completed in 2010 for NWMO determined that:

1. There was little improvement of the thermal characteristics of pellet materials through use of exotic materials such as copper powder or minerals such as rutile.
2. The use of a crushed or natural fine-grained silica powder showed substantial improvements could be achieved in the thermal conductivity of individual pellets and so further assessment of that option was warranted.
3. Particle packing for pellet materials was very dependent on the size and shape of the pellets and so a larger range of sizes and shapes should be evaluated.

Questions related to the materials that could physically resist the erosive action of flowing groundwater in the annular spaces between the HCB and rock in the IFB in the period prior to buffer swelling and closure of this gap were raised and are initially addressed in the new work described below. This issue is also relevant to the pellet materials to be placed in the gap between the backfill blocks and tunnel walls of a repository. The source of the bentonite (and perhaps also the quality required) to be used in manufacturing of pellets for different locations/applications is not the same throughout a repository. The various organisations represented in this joint project are also considering different clay sources/suppliers for their bentonite (and swelling clay) components. As a result, several bentonite materials were included in this study in order to determine how the source/quality of bentonite might affect pellet manufacture and behaviour.

Additionally, there exists the potential to use extruded rather than roller-compacted bentonite pellets in various locations in a repository. These extruded clay pellets are being evaluated as part of the Pellet Optimization Project, with most of the work related to that material being undertaken by Posiva. Many of the same issues and questions related to material composition options, durability and mechanical performance for the roller-compacted materials are present for the extruded materials. Some of the initial work conducted AECL's Geotechnical Laboratory has been included in this report, but most will be provided in a report to be produced by Posiva by early 2013.

Beyond the issues described above, consideration of materials that could provide resistance to longer-term removal of bentonite from the IFB by providing a filter medium along the rock-HCB interface was also identified as a topic of interest.

Two materials were identified as being potentially suitable as additives to bentonite during the pellet manufacturing process. Fine-grained silica and illite clay were both evaluated with respect to their thermal conductivity, as-placed density and ability to resist mechanical erosion.

4.2 TEST MATRIX

As part of the manufacturing and optimization study, a number of laboratory tests were conducted in order to identify key parameters and properties of pellets produced at AECL's Laboratory. These key parameters and properties of these pellets evaluated by AECL are listed as follows:

- Determination of density of individual pellets;
- Pouring trials to determine bulk density of pellets and evaluate ability of materials to be placed effectively;
- Effect of minor vibration on bulk density of poured pellets;
- Durability of pellets (e.g., visual evaluation of pellets, crush strength);
- Thermal conductivity of as-placed, poured pellet mass (using NWMO equipment located at AECL's Geotechnical laboratory); and
- Free swell tests involving placing materials in artificial groundwater solutions (0, 35, 70 and 275 g/L TDS, the latter being equivalent to NWMO's reference groundwater for a sedimentary environment) to evaluate effect of material type and admixtures on rate of pellet breakdown.

Several different bentonite materials of interest to NWMO, SKB and Posiva were examined as well as illite clay and fine silica sand fillers. Filler contents of 10, 25 and 50% by weight were tested in order to assess the potential utility of such materials in filling gaps between the UFC and the rock in the In-Floor Borehole geometry as well as in tunnel backfilling applications.

Stock materials selected for pellet production included:

- Wyoming bentonite;
- Asha bentonite;
- Milos AC200 bentonite;
- Milos B bentonite;
- Wyoming bentonite blended with 10, 25 or 50% silica sand;
- Wyoming bentonite blended with 10, 25 or 50% illitic clay.

The above stock materials were used to produce three different sizes (and shapes) of pellets using a laboratory scale briquetting machine. These included:

- Large (Oblong: 22 mm long x 14 mm wide x 10 mm thick);
- Medium (Oblong: 22 mm long x 11 mm wide x 7 mm thick); and
- Small (Round: 9 mm diameter x 6 mm thick).

A total of 56 batches of pellets were made for the study. Based on preliminary characterisation results six pellet types were selected for additional advanced testing by VTT in Finland, which is on-going. The selected pellets included:

- Large pellets made with Wyoming bentonite;
- Small pellets made with Wyoming bentonite;
- Small pellets made with 75% Wyoming bentonite and 25% silica sand;
- Small pellets made with 75% Wyoming bentonite and 25% illite;
- Small pellets made with Milos AC200 bentonite; and
- Small pellets made with Milos B bentonite.

The pellets were assessed at AECL primarily to evaluate potential to improving their density, strength, durability and heat transfer capability.

Table 4 presents a test matrix that focuses on materials that could be of use as gap fill pellets for the IFB or HTP geometries. A total of 38 variations of composition, water content and compaction load were examined in the course of testing materials for use in “buffer-type” applications. Values of water content, individual pellet bulk density, crush strength, and free swell were determined for all pellets produced. On the selected pellets, thermal conductivity tests were carried out, which also provided poured and vibrated densities for these materials. Table 5 presents a test matrix for pellets of particular interest in backfilling of tunnels associated with the block and pellet backfilling concept. This matrix of 18 test variables included three types of clay and two different pellet sizes. In addition, Cebogel extruded pellets, Pellets produced by MX-80 in 2008 and MX-80 pellets produced in 2011 (used in Posiva’s Buffer Test project) were examined as part of the AECL testing program.

Beyond the work completed at AECL, there were other associated tests that were considered as part of the study scope. Based on the results of the pellet production and testing conducted at the AECL laboratory, selected pellets were produced and sent for further detailed testing at the SKB and Posiva laboratories. This work was proposed to be included, as part of the final project report to provide additional depth to this project. Six of the test batches produced by AECL (Batch No. 51, 52, 53, 54, 55 and 56), were selected by Posiva and SKB for further evaluation in their laboratories. Approximately 75 kg of each of these batches were produced and shipped to Europe.

SKB and Posiva conducted additional material testing and property analyses on pellet materials produced in the course of this study, including:

- Large wall gap filling tests to evaluate pour density of customized pellets;
- Artificial wetting of gap using customized pellet sizes and composition (assessing sealing ability/time, swelling pressure, vertical uplift risks, moisture and density distribution with time);
- Void ratio and water flow ability with customized pellet size (assessing permeability and ability to use artificial wetting);
- Buffer system design (achievable densities with customized pellet size and composition);
- Durability tests on pellets (MicroDeval Wear Resistance Test) to evaluate handling and fracture risks;
- Conduct of extruded pellet test production using “optimised” materials identified in roller-compaction production and evaluation to provide comparison between products produced by two techniques;
- Erosion tests; and
- Water storage capacity tests.

On completion of the pellet studies, a limited number of materials have been selected for further evaluation by SKB and Posiva. In particular some materials will be included in an extruded pellet manufacturing study being undertaken by VTT for Posiva. These tests are intended to determine if extrusion can produce materials comparable to roller compacted materials with respect to density and behaviour. This might also require some placement tests using extruded materials for comparison purposes.

The results obtained from the pellet manufacturing and optimization study have been used for input into the on-going work of these groups, especially with regards to identifying some potentially useful materials for inclusion in the on-going testing and demonstration programs of Posiva and SKB.

Table 4: Test and Production Matrix for Pellets for Potential use in Gap-filling (IFB and HTP geometries)

Material Composition	Batch Number	Number of Batches	Pellet Size	Tests							
				Average Pellet Water Content	Average Pellet ρ_b	Crush Strength	Bulk Density		Thermal Conductivity		Free Swell
							Poured	Vibrated	Poured	Vibrated	
100% Wyoming Bentonite	1,2,3,56	4	Large	√	√	√	3,56	56	56	56	√
	43	1	Medium	√	√	√	43	43	43	43	
	18,19,20,21,28,29,51	7	Small	√	√	√	21,29,51	29,51	29,52	29,51	
10% Silica Sand	4	1	Large	√	√	√	-	-	-	-	√
	47	1	Medium	√	√	√	47	47	47	47	
	24,30	2	Small	√	√	√	-	-	-	-	
25% Silica Sand	5	1	Large	√	√	√	5	5	5	5	√
	45	1	Medium	√	√	√	45	45	45	45	
	25,31,54	3	Small	√	√	√	25,54	54	54	54	
50% Silica Sand	48	1	Medium	√	√	√	-	-	-	-	√
	40	1	Small	√	√	√	40	40	40	40	
10% Illite	6,7	2	Large	√	√	√	7	7	7	7	√
	46	1	Medium	√	√	√	46	46	46	46	
	26,32	2	Small	√	√	√	-	-	-	-	
25% Illite	8,9	2	Large	√	√	√	8,9	8	8	8	√
	44	1	Medium	√	√	√	44	44	44	44	
	27,33,53	3	Small	√	√	√	33,53	53	53	53	
50% Illite	49,50	2	Medium	√	√	√	50	50	50	50	√
	38,39	2	Small	√	√	√	38	38	38	38	

Note: Numbers entered in table are those assigned to pellet batches

Table 5: Test and Production Matrix for Pellets for Possible use in Tunnel Backfill

Material Composition	Batch Number	Pellet Size	Tests							Free Swell
			Average Pellet Water Content	Average Pellet ρ_b	Crush Strength	Bulk Density		Thermal Conductivity		
						Poured	Vibrated	Poured	Vibrated	
Milos AC200 (High Quality)	41	Large	√	√	√	√	-	-	-	√
	42	Large	√	√	√	√	√	√	√	
	36	Small	√	√	√	-	-	-	-	
	37	Small	√	√	√	√	-	-	-	
	52	Small	√	√	√	√	√	√	√	
Asha	12	Large	√	√	√	-	-	-	-	√
	13	Large	√	√	√	-	-	-	-	
	14	Large	√	√	√	√	√	√	√	
	15	Large	√	√	√	-	-	-	-	
	16	Large	√	√	√	-	-	-	-	
	17	Large	√	√	√	√	-	-	-	
	34	Small	√	√	√	√	√	√	√	
	35	Small	√	√	√	√	-	-	-	
Milos B	10	Large	√	√	√	-	-	-	-	√
	11	Large	√	√	√	√	√	√	√	
	22	Small	√	√	√	-	-	-	-	
	23	Small	√	√	√	-	-	-	-	
	55	Small	√	√	√	√	√	√	√	
Cebogel Pellets*		extruded	√	√	√	√	√	√	√	√
Buffer Test MX-80*		Small	√	√	√	√	√	√	√	√
SKB MX-80*		Small	√	√	√	√	√	√	√	√

Note: Numbers are those assigned to pellet batches, * Pellets supplied from others, size differs from AECL-produced materials

4.3 MATERIALS AND METHODS

4.3.1 Materials Examined in Study (Bentonite, Illite, Silica Sand)

The materials evaluated as part of the Pellet Optimisation Project are listed below with more details available from the suppliers' data sheets and properties summaries provided in Appendix A.

Wyoming Bentonites

- BC-NSB-200-2008: Bentonite Corporation-National Standard Bentonite, 200 mesh Wyoming-type bentonite. Produced in 2008 by the Bentonite Corporation USA. Referred to as Wyoming bentonite in this study since it is the material used in the majority of the testing. If other materials are used they are specifically referenced in the text.
- ACC-MX-80-2001: An 80-mesh granular Wyoming bentonite, marketed by American Colloid Company through a variety of distributors (e.g., AMCOL Specialty Minerals and Askiana (see Appendix A)). This product is referred to as MX-80 in this study. This material was used to manufacture pellets for generic testing and Posiva's Buffer Test conducted in 2011.

Other Bentonites

- Milos AC200: Also referred to as Milos HQ (High Quality), Milos A,. This bentonite is sourced from Milos Greece and is known to have a high (>75%) montmorillonite content. This material is referred to as Milos AC200 in this document.
- Milos B: Also known as IBECO RWC-BF. This bentonite is raw, crushed clay sourced from Milos Greece, and known to have a relatively low (~60%) montmorillonite content. It is referred to as Milos B in this document.
- Asha-2010: A raw, coarsely crushed bentonite-rich clay from Kutch India. Referred to as Asha in this document.
- Cebogel QSE-2010: Trade name for commercially-available pellets, made of an activated Na-bentonite sourced from Milos Greece, and pelletised by Cebo Holland BV in 2010. This material is extruded bentonite rods of 5-20mm length and 6.5mm diameter. It is referred to as Cebogel in this document.

The materials and products used in this study have been used in a variety of previous studies and applications by the participating organisations and in many cases differing reference names have been used to describe the same (or very similar) product. In an effort to standardise the naming protocol and link the work in this report to other studies, a summary of equivalent names is provided in Table 6. A brief summary of their physical and mineralogical properties of these materials is then provided in Table 7.

The naming protocol includes the producers' initials followed by the product specification (1 to 3 sets of initials) and then the year of material production. For example IBECO-RWC-BR-2008 indicates IBECO as the manufacturer, RWC-BR as the specific product, produced in 2008.

For ease of reference in the text, the bentonite products are generally referred to by their short-form names:

Wyoming Bentonite = BC-NSB-200

MX-80	=	ACC-MX-80
Milos AC200	=	IBECO-RWC-2008
Milos B	=	IBECO-RWC-BF-2008
Asha	=	Asha NW-BFL-L 2010
Cebogel	=	Cebogel QSE-2010

Two products not commonly referenced in current engineered barriers application, but which were used in this study are:

Illite Clay

A crushed illitic shale produced and marketed in Canada as a cement plasticizer. The material was sold under the trade name Sealbond (CB-Sealbond-1985) during the 1980s and 1990s. A single batch was purchased by AECL during the 1980's and has been used for all research work. Although the source deposits still exist, it is no longer available commercially. The material is 1-3% fine sand, 65-71% silt, and 28-32% clay. It is referred to as illite in this document and its basic properties have been reported by Radhakrishna and Chan (1982; 1985).

Silica Sand

A commercially marketed crushed quartzite, fractionated to meet 70-140 mesh size range (fine sand >99%, silt <1%, clay 0%).

4.3.2 Pellet Manufacturing

Using the raw materials discussed in Section 4.4.1, a total of 56 batches of pellets were produced at AECL's Geotechnical Laboratory (Table 8). This work was conducted over the May 2011 to June 2011 period. Depending on the quality of pellet produced, the majority of the 56 batches of pellets (~2-5 kg each) were subjected to basic characterisation tests (e.g., average pellet water content, pellet density, and crush strength of individual pellets). Based on the results of the basic characterisation tests, as well as general physical appearance, selected batches of higher quality pellets were subjected to further testing (e.g., density of a poured mass of pellets, density of a vibrated mass of pellets, thermal properties of the poured and vibrated masses of pellets, and free swell testing). The testing procedures are described in Section 4.4.3.

The compositions of the pellets to be manufactured and tested were established by the partner organisations at the project development stage. The selection of materials was different for buffer-rock gap fill applications and general tunnel backfill applications.

Blends produced for buffer-rock gap fill applications include:

- 100% Wyoming bentonite;
- Wyoming bentonite containing 10, 25 or 50% silica sand;
- Wyoming bentonite containing 10, 25 or 50% illitic clay.

Materials being considered for use in general backfilling applications include the Asha, (Asha NW-BFL-L 2010); Milos B (IBECO-RWC-BF-2008); Milos AC200 (IBECO RWC 2008), Cebogel (QSE-200) and MX-80 bentonites.

Table 6: Summary of Products used in Pellet Optimisation Project

Name used in this report	Reference Name(s)	Other Names, Similar Products	Producer	Product Type	Granularity	Dominant Mineral (%)
Wyoming Bentonite	BC-NSB-200-2008 BC-NSB-200-2005	National Standard Bentonite	Bentonite Corporation	Bentonite	200 mesh product	Montmorillonite 75-90
MX-80	ACC-MX-80-2001 ACC-MX-80-2010	MX-80	American Colloid Co.	Bentonite	80 mesh product	Montmorillonite 75-85
Milos AC200	IBECO-RWC-2008	Milos A Milos HQ	S&B Industrial Minerals	Bentonite	Granules	Montmorillonite 75-80
Milos B	IBECO-RWC-BF-2008	NN	S&B Industrial Minerals	Bentonite	Granules	Montmorillonite 50-60
Asha	Asha NW-BFL-L 2010	Asha 230A	Kutch India	Bentonite	Granules	Montmorillonite 60-65
	Asha 230B***		Kutch India	Bentonite	Granules	Montmorillonite 78-85
Cebogel	Cebogel QSE-2010	Cebogel Pellets	Cebo Holland BV	Bentonite	Extruded bentonite pellets using activated IBECO RWC-2010-type material	Montmorillonite ~80
Silica Sand	Silica Sand	Quartz sand	Indusmin*	Crushed Quartzite	70-140 mesh (0.212 - 0.104 mm)	Quartz >>95
Illite	CB-Sealbond -1985	Crushed Illitic shale	Canada Brick**	Illitic Shale	Silt-sized product	Illite 35-50 Qtz 20, Kaolin 15-20

* This supplier is no longer in business; there are multiple suppliers of similar products available

** This supplier is no longer in business and product not commercially available. The formation used to supply this material is still accessible.

*** This is provided for information only and was not included in current test series, Literature references exist for this higher-bentonite content product.

Table 7: Properties of Materials Investigated in Pellet Optimization Project

Short Form Name (used in this report)	Other Name(s) Sometimes Used	Dominant Mineral (%)	Main Accessory Minerals	Liquid Limit %	Particle Density (g/cc)	Cation Exchange (meq/100g)	Free Swell Freshwater (cc/2g)
Wyoming Bentonite	National Standard Bentonite, BC-NSB-200-2008 BC-NSB-200-2005	Montmorillonite 75-90 (75)	Quartz, Feldspar, Tr. <2% each Calcite, Gypsum, Illite	514, 536	2.70	92	26
MX-80	ACC-MX-80-2010 ^(3,4) ACC-MX-80-2001	Montmorillonite 75-85 (75)	Quartz, Feldspar, Kaolinite Tr. <2% ea. Calcite, Gypsum	450-550	2.78	75, 84-104 ⁽⁵⁾	34-42
Milos AC200	Milos A Milos HQ ^(6,7) IBECO-RWC-2008 IBECO Deponit Ca-N-2008 ⁽¹³⁾	Montmorillonite 75-80 (80)	Illite, Feldspar, Kaolinite, Calcite, Dolomite, Albite, Quartz, Gypsum	464 ⁽¹⁴⁾	2.65 2.84 ⁽¹⁴⁾	75-111 >80	27, 20 >5
Milos B	Milos B ^(3,4) IBECO-RWC-BF-2008	Montmorillonite 50-60 (58)	Calcite, Dolomite, Feldspar, Illite	150-157 115, 215 ⁽¹⁴⁾	2.78, 2.79 ⁽¹⁴⁾ 2.65	60-72 60±10	10, 13 ⁽¹⁴⁾ >7
Cebogel	Cebogel QSE-2010 ^(4,6)	Montmorillonite ~80	Quartz, Feldspar, Calcite, Dolomite	576		99-103 107	28 ⁽¹²⁾
Asha	Asha 230A WR2009-11 Asha NW-BFL-L 2010	Montmorillonite 60-65 (65)	Quartz, Feldspar, Calcite, Gypsum, Illite	180		83-93	27 16.8
	Asha 230B ^(3,4,8)	Montmorillonite 78-85 (80)	Quartz, Feldspar, Kaolinite	424, 474	2.90	83-93	27
Silica Sand	Crushed Quartzite 70-140 mesh (0.0.074-0.212mm)	Quartz >>95	Tr. <1% each Pyrite, Feldspar, Calcite	NM	2.65	<< 1	NS <2
Illite	Illitic Shale CB-Sealbond-1985 ^(1,2,11)	Illite 35-50	Kaolin 15-20, Quartz ~20, Feldspar, Chlorite, Vermiculite Tr. <2% each Calcite, Horneblende	28-31	2.70-2.79	10-18	NS <2 ⁽¹¹⁾

NM- This parameter is not measurable for the material noted

NS – Non-Swelling

1. Quigley 1984

2. Oscarson and Dixon 1989

3. Johannesson and Nilsson 2006

4. Sandén et al. 2008

5. Keto et al. 2009

6. Ahonen et al. 2008

7. Carlson 2004

8. Johannesson et al. 2008

9. Olesson and Karnland 2009

10. Sandén et al. 2008

11. Dixon 1995

12. Marjavaara and Kivikoski 2011

13. SKB 2010

14. Kiviranta 2011

Pellets were made from the above-listed materials using a small (laboratory-scale), roller-type briquetting machine rented for the duration of the project (Figure 13). The same machine used for the testing program completed in 2010 (Man et al. 2011), was used in this study. Pellets were manufactured by feeding the stock materials into the briquetting machine. As mentioned above, this type of machine produces pellets by forcing loose stock material between two rollers rotating in opposite directions. Each roller is machined with one half of the pellet shape (Figure 13). Stock material is placed in a hopper located above a feed screw. The feed screw forces the loose material between the two rollers. The rollers are forced together as stock material is directed between them. Finished pellets are gravity fed to a bucket via a chute. The test-scale machine allowed for the production of approximately 40-50 kg of material per hour, which was adequate for production for laboratory applications. The pressure achievable using this machine was approximately 4 times that previously required to manufacture pellets to a dry density of $\sim 1900 \text{ kg/m}^3$ so its compaction capacity was adequate.

Three different sizes of pellets were made for buffer-rock gap fill applications. These were identified as small (S), medium (M) and large (L) (Figure 14). The small pellets were disc-shaped, with a diameter of 9 mm and a thickness of 6 mm. The medium pellets were oblong-shaped, measuring 22 mm long by 11 mm wide by 7 mm thick. The large pellets were also oblong-shaped, measuring 22 mm long by 14 mm wide by 8 mm thick. These large pellets were manufactured using the same rolls as the preliminary pellet testing program.

The sizes and compositions of the pellets produced in the course of this study are provided in Table 5. Most of the batches listed in Table 5 represent small production runs (2-5 kg each), sufficient for basic evaluations (e.g., moisture, density, strength, free swell and in most cases poured density and thermal properties), but not necessarily for conduct of erosion tests or large-scale gap filling trials. For the tests requiring larger quantities of material, the results of preliminary trials were evaluated and a limited number of larger production runs (50-80 kg each) were completed. For backfill applications, only the small (S) and large (L) sizes were selected by the project participants for further evaluation.

The preliminary trials with the roller compactor examined a range of variables intended to identify optimal machine settings for production of good quality pellets. The variables considered included: rate of material feed into the rollers, rate of roller rotation, compressive force maintained between the rollers, gravimetric water content of the feed material and the size/shape of the pellets manufactured. Each of these factors needs to be optimised for each different material and roller type. For each stock material and pellet size, various production trials were conducted by changing water content of the stock materials, roller loads, and feed rates. Details related to the settings used during the optimisation process for each batch manufactured were recorded and are provided in Appendix A. Visual appearance (darker colour than stock material, as illustrated in Figure 15) and strength (resistance to be broken by hand) were used as initial indicators of pellet quality and the need to adjust the production variables. This generally corresponded well with the basic characterisation tests.

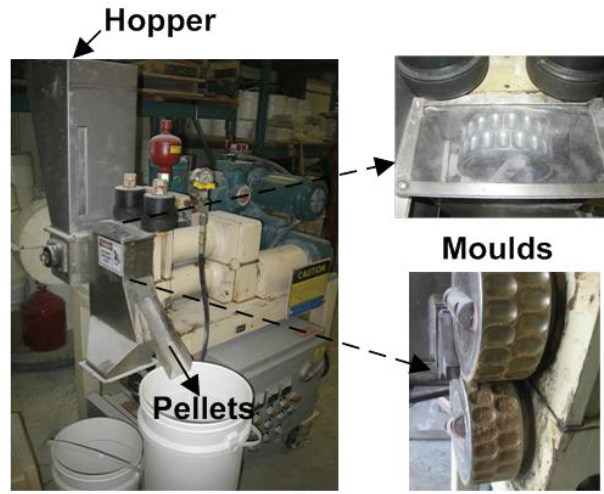
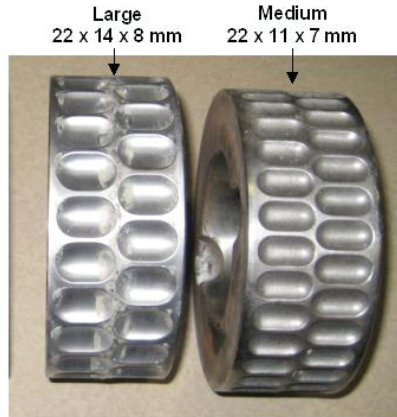
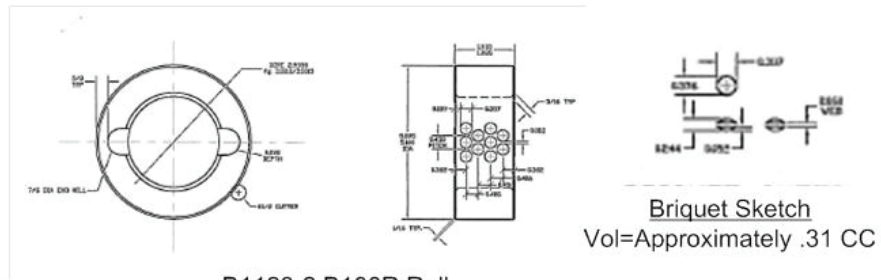

Figure 13: Pellet Making Machine Showing Rollers



(a) Large and Medium Moulds

Small (Machined for This Project)
9 mm Diameter x 6 mm Thick



B1123-2 B100R Roll
35 Pockets Around, 4 Staggered Across
440C SS, HT 52-54 Rc

(b) Small Mould

Figure 14: Sizes of Moulds used in Making Pellets



Figure 15: Colour Difference Between a Stock Mixture and Finished Pellets

Evaluation of the variables associated with the manufacturing of the pellets determined that machine setting for ~6-8 rpm, 1500 psi roller contact pressure and use of relatively low water content produced the most consistent quality of pellet. Small variations in any of these variables did not discernibly affect the density or quality of the material produced (see Section 5.1.1) and so for the most part, these variables were fixed for the course of the pellet manufacturing process. Details related to the settings for each batch manufactured were recorded and are provided in Section 5 and in the data tables provided in Appendix B.

Stock materials were blended in a batch mixer at their as-shipped water contents. Water contents of the stock materials ranged from 4.0% to approximately 16% by weight. Initial trials indicated that the addition of substantial moisture resulted in the stock material sticking to the rollers. This produced low density pellets of inconsistent size, and so no moisture amendment was done during blending of the feed materials. The final moisture content of the materials was measured prior to manufacturing of pellets, and on the individual batches of finished pellets. The water content of the individual pellets decreased with increased compression pressure due to the increased heat associated with higher compression pressures.

Examples of some of the pellets produced are shown in Figure 16. Many of the pellets produced had a fine webbing of compacted material between the individual pellets (Figure 16j). This webbing had the potential to adversely affect the ability of the pellets to flow smoothly during pouring and thereby reduce the packing efficiency of the pellets. Removal of the web was accomplished at AECL by gently tumbling the pellets in a drum-line sieve. This tumbling did not cause any damage to the pellets and simply removed the webbing. Similarly, MX-80 pellets produced in Europe for use in Posiva's Buffer Test were placed in a 50 kg capacity concrete pan mixer for 2 minutes then screened with a 4 mm mesh, resulting in average of 3.7% fines removed.

The machine used in the Dixon et al. (2005) study was of slightly different design than the one used in the 2010 and 2011 studies and this seems to have affected the water content required for optimised compaction and the cosmetic nature of some of the larger pellets produced. It was noted early in the current study that the machine used was unable to consistently produce pellets at the gravimetric water contents initially targeted during the planning for this testing

program (>12%). When operated and supplied with feed material at ~12% gravimetric water content the compactor rapidly heated up and in some cases the machine had to be shut down to prevent overheating and tripping thermal safety devices. Where pellets could be produced, there were often issues related to the release of the pellets from the mould as the wheels rotated. As a result the water content of the feed material was decreased substantially and pellet production was possible. This lower water content in the feed material was attributed as being the reason for some physical defects observed in the large pellets produced (Figure 17). This was typically manifested as ribbing along the contact of the two halves (location of web between pellets) of some of the medium and larger sized pellets (Figure 17), or other cracks in pellet surfaces. In most cases these cracks appeared to be mostly cosmetic in nature (see Section 5.1), with the pellets retaining substantial crush strengths (Section 5.4).

Table 8: Pellet Production Matrix

Composition	Small (9 mm diameter, 6 mm thick)	Medium Oblong (22 mm long, 11 mm wide, 7 mm thick)	Large Oblong (22 mm long, 14 mm wide, 8 mm thick)
Buffer-Rock Gap Fill:			
100% Wyoming bentonite	7 batches	1 batch	4 batches
90% Wyoming bentonite and 10% silica sand	2 batches	1 batch	1 batch
75% Wyoming bentonite and 25% silica sand	3 batches	1 batch	1 batch
50% Wyoming bentonite and 50% silica sand	1 batch	1 batch	0 batches
90% Wyoming bentonite and 10% illite clay	2 batches	1 batch	2 batches
75% Wyoming bentonite and 25% illite clay	3 batches	1 batch	2 batches
50% Wyoming bentonite and 50% illite clay	2 batches	2 batches	0 batches
General Tunnel Backfill:			
100% Asha bentonite	2 batches	0 batches	6 batches
100% AC200 bentonite	3 batches	0 batches	2 batches
100% Milos B bentonite	3 batches	0 batches	2 batches

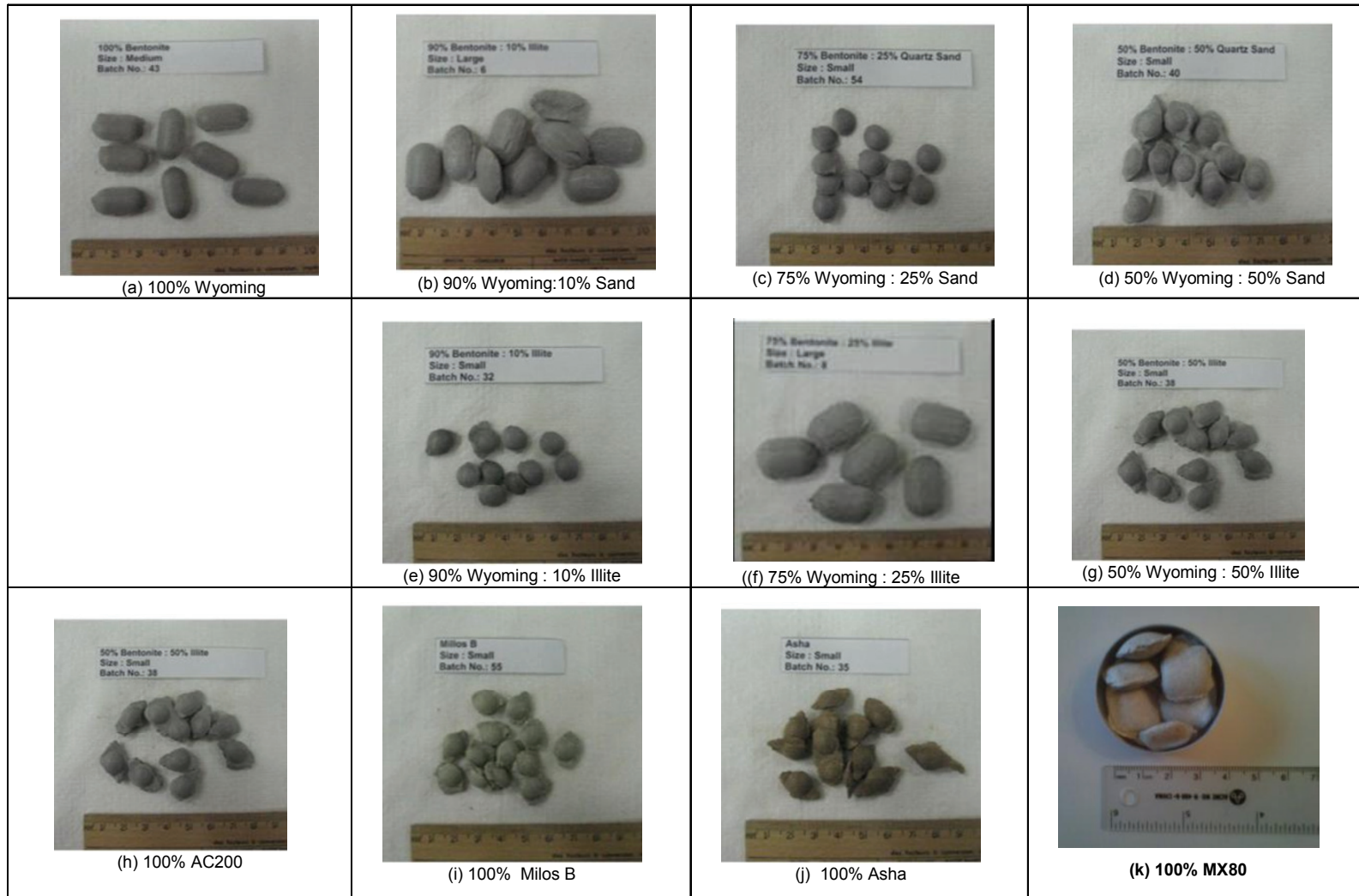

Figure 16: Examples of Pellets Produced for Pellet Optimisation Study



Figure 17: Visual Appearance of Large Pellets Exhibiting Surface Defects

4.3.3 Pellet Testing

Pellet Density

The pellets of various sizes, shapes and compositions produced in the course of this project were all analysed to determine the bulk and dry densities of the individual pellets. This was done using a standard technique for assessing the bulk density of cohesive soil materials (ASTM D-1188). The test involves thinly coating a pre-weighed specimen in paraffin wax. The coated specimen is then weighed again in air and while suspended in a volume of water. From these measurements it is possible to calculate the volume of the specimen, the bulk density and following conduct of a gravimetric water content analysis on the pellets, the dry density of the individual pellets.

In this study, all of the trials that produced pellets that were durable enough to survive subsequent handling had their bulk and dry densities determined in the laboratory. The results of these measurements are provided in Section 5.2.

Free Swell Tests

The ability of the pellets to take on water, swell and ultimately entirely fill the volume into which they were placed is a key behavioural requirement for fill materials. With the range of clay materials and clay-additive materials examined in this study, measurement of the ability of the pellets to swell is required. The pellets manufactured for use in this study were made using the water naturally present in the raw clay, a material that was slightly dried, or if necessary the water content was increased through use of deionised water. No saline solutions were used to replace or adjust the water content of the material being compacted. The swelling capacity of these pellets was measured in a range of artificial groundwater compositions, representing the full-range of conditions that might be encountered in the granitic repositories of SKB and Posiva or the sedimentary rock environment being considered by NWMO.

Free swell measurement was accomplished by placing approximately 5 g of pre-weighed (and known gravimetric water content), pellet material in the bottom of a volumetric cylinder (250 or 500 ml volume) and then gently filling the cylinder with the solution being assessed. As the pellets disaggregate the volume they occupy is measured. On completion of swelling the volume occupied by the pellets is recorded. Free swell is defined as the volume occupied by 1 gm of oven-dried clay, so the volume occupied by

the clay is divided by the dry mass installed in the cylinder (it is typically expressed in cm^3/g). The results of the free swell testing are provided in Section 5.3.

Crush Strength

Crush strength tests were conducted on the all batches of the pellets to determine the resistance of the individual pellets to compressive force. As strength measurement is sensitive to strain rate a modified triaxial load frame was used to allow for a consistent strain rate during testing (Figure 18a) and all tests were repeated at least three times to provide average and standard deviation values. The strength measured will also be dependent on the size and shape of the pellets so comparison of results must be done carefully and results of similarly sized pellets are assessed in terms of their relative strength.

Crush strength was measured using a load cell that was sitting on a customized metal plate (Figure 18b). The triaxial load frame was used to compress the pellets at a speed rate of 1 mm per minute (Figure 18c). A data logger recorded the compressive force versus time. Four pellets per batch were examined and the average crush strength value with standard deviation and strain was calculated.

Results were evaluated based on comparison of pellets of the same size and shape. When comparing identically sized pellets it should be possible to determine relative changes between pellets of differing composition and water content. It would be expected that pellets of differing size but otherwise identical composition and density would exhibit differences in their crush strength requirement. Details of the test results are provided in Section 5.4.

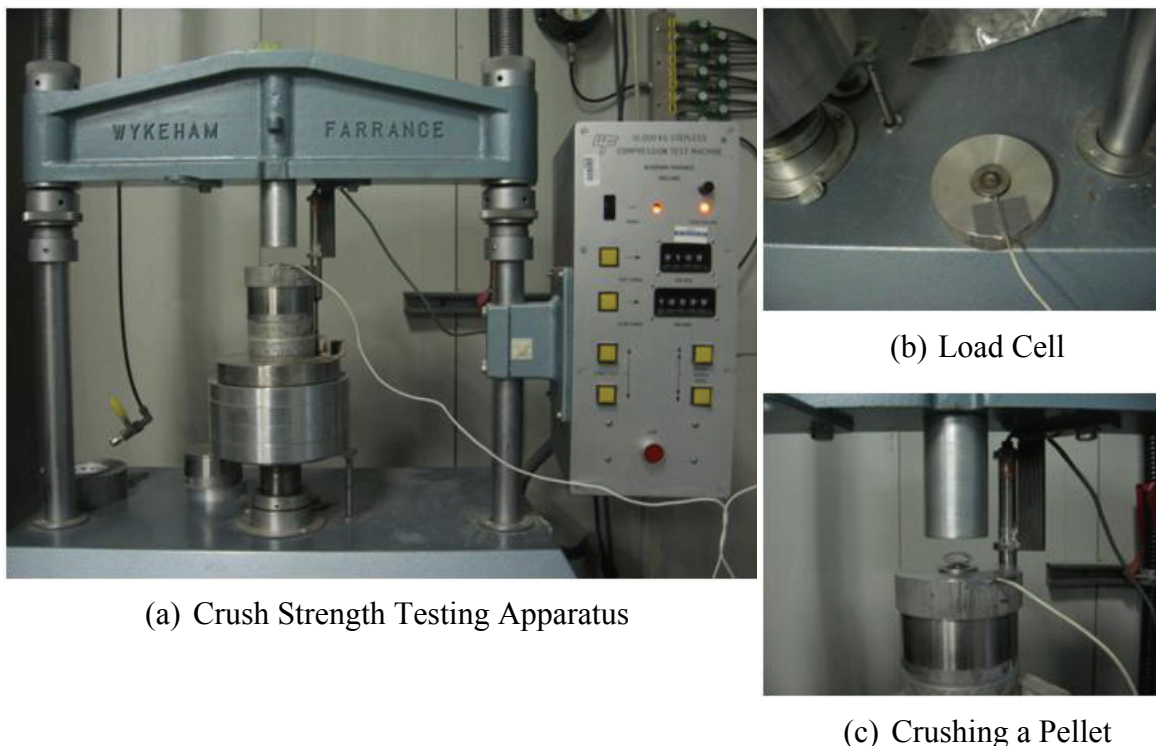

Figure 18: Device used to Determine the Crush Strength of Pellets

Measurement of Bulk Density (Poured and Vibrated)

For selected pellet batches, bulk density of a poured mass of pellets was measured, using a free fall pouring method. This is a simple test where pellets are poured into a container of known volume and the mass is measured in order to calculate a bulk density. No densification beyond that caused by gravity is applied. The AECL test used two types of containers, a long cylindrical beaker and a Plexiglas box, to measure bulk density; as shown in Figure 19. Different volume beakers from 200 ml to 500 ml were used due to a small amount of pellets available for some batches. The Plexiglas box was also used for measuring the bulk density of the pellets after application of vibratory densification. The laboratory procedure to determine the vibration-induced densification of the poured pellets is a low-energy method that is not calibrated against field techniques but does provide a uniform means of comparing the ability of loosely poured materials to be further densified. The use of a square placement box to determine the loose and vibration-densification of the pellets also allowed measurement of the thermal conductivity of a mass of pellets at a known poured density and compacted density.



(a) Long Cylindrical Beaker



(b) Plexiglas Box



(c) Electric Shaker

Figure 19: Bulk Density Tests using Different Poured Geometries

The tests conducted by AECL involved small volume containers and as noted in Section 3, there are differences in what can be achieved in small versus large placement geometries. In conjunction with the small-scale tests undertaken on a large proportion of the small batches of materials tested in this study, larger scale tests were completed by

VTT as part of the assessment work undertaken on the large batches of pellets sent to them by AECL. The VTT tests involved determining the bulk (dry and wet) density of a larger mass of pellets using a geometry where a narrow (2000 mm long by 35 mm wide) gap was present and the pellets needed to fall as much as 1.14 m from the point of pouring (Figure 20). The setup is described in detail by Marjavaara and Kivikoski (2011). The average density of the large volume of fill was determined by dividing the measured mass of pellets used to fill a known elevation in the fixed geometry of the frame. In addition to pellets available at VTT (Cebogel and Buffer Test pellets), AECL provided large batches (60-75 kg each) of six of the pellet types produced in Canada to SKB and Posiva for further analysis. The tests undertaken by VTT required ~70 kg of pellets for each pouring where no additional densification was applied. Due to limitations in the quantities of materials available it was only possible to do large volume pour tests on four of the six pellet types from Canada. For each type of pellet examined, the filling test was repeated three times. The results of the gap filling bulk and dry density measurements are presented in Section 5.5.



Figure 20: Large Pellet Pouring Test Frame at VTT

Abrasion Resistance Tests at VTT

The abrasion resistance of pellets is tested to provide an indication of how pellets would react to handling. The risk of cracking, flaking or disintegration due to wear and movement could be assessed. In order to assess the potential suitability of various material composition, size and composition options for pellet fill, determining the ability of selected pellets to withstand physical erosion is an important parameter. Six of the pellet types produced in the course of this screening study were selected and batches of approximately 75 kg of each were produced and shipped to VTT Finland for conduct of large-scale pour testing (see above) as well as abrasion testing.

Abrasion testing provides a measure of the relative durability of the materials selected for further evaluation. There is no formally documented standard procedure for conduct of abrasion testing of clay-based pellet materials but the abrasion test for aggregate (stone and rock) can provide a relative measure. The abrasion resistance of the bentonite pellets was assessed using the Micro-Deval test. The test was done according to the EN standard method (EN 1097-1), using the alternative method of Appendix A of this technique's instructions for conduct where no water is added to the drum. This test equipment is shown in Figure 21.



Micro-Deval test equipment



Large bentonite pellets tested for wear resistance, before (left) and after testing (right).

Figure 21: Abrasion Testing Equipment and Example of Results of Abrasion Testing of Clay Pellets

Prior to the AECL pellet testing, some background trials were done on bentonite pellets to establish if the standard limits would be followed or if a modified version would be used. The test parameters were set to get partial degradation of the pellets, so that the wear resistance could be compared between pellet types. The goal was not to get full disintegration or no disintegration, yet to get something between. It was established that the test method could be used according to the standard, with dried pellets. Using pellets with the as-delivered moisture content (5-10%) resulted in poor results with particle agglomerates forming due to compaction caused by the impact of the steel balls.

In order to test the pellets without risk of particle agglomeration the technique was modified slightly and used for all the materials evaluated. In these tests, 500 grams of pellets were first oven-dried for 24 hours at 110°C. They were then cooled and placed in the drum along with 5000 grams of steel balls. The drum was then sealed and subjected to 12 000 revolutions with a speed of 100 revolutions per minute. After the test, the lost material (fines) was screened on a size 1.6 mm sieve and the mass loss percentage was reported. Figure 21 shows an example of the before and after condition of the pellets.

Measurement of Thermal Properties

The measurement of thermal properties was conducted in conjunction with the determination of poured and vibrated densities for a given mass of pellets. The apparatus used to measure the thermal properties of a mass of pellets is shown in Figure 10. The device used in the thermal properties testing was the same Hot Disk Thermal Constants Analyzer used in the 2010 study (Section 3.3.2). The system operates by supplying a pulse of constant heat to a sample sensor, which acts as both a heat source for increasing the temperature of the sample and a resistance thermometer to monitor the change in temperature after the heat pulse. The sensor itself consists of an electrical conducting pattern in the shape of a double spiral etched out of a thin sheet of nickel. The conducting pattern is supported on both sides with a thin insulating material consisting of Kapton.

The test configuration shown in Figure 10 and used in this study is known as a one-sided test. It is performed by taking measurements with the test material in contact with only one side of the sensor. The other side of the sensor is in contact with an insulating material with pre-determined thermal properties. In this test series, rigid foam insulating material was used as the backing material. The material being tested was first poured into the container (of known volume) and then a thermal properties measurement was made. After a cooling period, the material was vibrated as discussed above, and then the thermal properties test was repeated on the compacted mass of pellets.

The solution of the thermal conductivity equation is based on the assumption that the sensor is located in an infinite material. This means the total time of the transient recording is limited by the presence of the outside boundaries and the limited size of the sample. An estimation of how far this thermal wave has proceeded in the sample during a recording is defined as the probing depth:

$$\Delta p = 2\sqrt{kt}$$

where Δp is the probing depth (i.e., the shortest distance from sensor edge to specimen edge), K is the thermal diffusivity; and t is the measuring time.

The distance from any point of the sensor to any point on the surface of the specimens must exceed Δp if the total measuring time is t . To determine both the thermal conductivity and thermal diffusivity with good accuracy, the thickness of a flat sample should not be less than the radius of the sensor.

The probing depth only provides an estimate of the required sample size as the thermal diffusivity of the material is unknown, but can be estimated from known properties of materials. In practice the determination is by an iterative process.

As the sensor is heated, the resistance increase as a function of time is given by:

$$R(t) = R_0\{1 + \alpha[\Delta T_i + \Delta T_{avg}(\tau)]\}$$

where R_0 is the resistance of the disk prior to heating and time $(t) = 0$, α is the temperature coefficient of resistivity (TCR), ΔT_i is the constant temperature difference that develops nearly immediately over the insulation on the sensors, and $\Delta T_{avg}(\tau)$ is the average temperature increase of the sample surface in contact with the sensor.

The temperature increase recorded by the sensors can be represented by:

$$\Delta T_{avg}(\tau) + \Delta T_i = (1/\alpha)\{[R(t)/R_0] - 1\}$$

with ΔT_i becoming a constant after a short time Δt . This can be estimated from:

$$\Delta T_i = (\delta^2/\kappa_j)$$

where δ is the thickness of the insulating layer, and κ_j is the thermal diffusivity of the layer material.

The time dependent temperature increase is given by:

$$\Delta T_i(\tau) = (P_0/\pi^{3/2}ak)D(\tau)$$

where P_0 is the power output from the sensor, “a” is the overall radius of the disk, “k” is the thermal conductivity of the sample, and $D(\tau)$ is a dimensionless time dependent function. The dimensionless time dependent function is:

$$\tau = \sqrt{t/\theta}$$

where t is the time measured from the start of measurement, and θ is the “characteristic time”. The characteristic time is defined by:

$$\theta = a^2/\kappa$$

By plotting the recorded temperature increase versus $D(\tau)$, a straight line is produced, the intercept of which is ΔT_i and the slope is $P_0/(\pi^{3/2}ak)$ using testing times longer than Δt_i . Because thermal diffusivity is not known before testing, the final straight line is determined through iteration. The results obtained for the pellet materials examined in this project are presented in Section 5.7.

Water Uptake by Pellets of Differing Size, Shape and Composition

One of the main objectives of the pellet optimisation work is to determine if changing the size, shape or composition of the pellets will affect the ability of this gap fill material to take on water and swell against its confinement. This is of particular importance in the period immediately following pellet installation and before an IFB or backfilled tunnel can be completely isolated. The more effective the pellet fill is in taking on rather than transmitting water, the longer will be the period before water movement can become an issue in the buffer or backfill. It is also possible that artificial wetting of the gap fill may be desirable in order to improve heat transfer during the period immediately after container placement. In such a situation a gap fill that allows for a uniform wetting would be more desirable.

Work to evaluate water movement through block and pellet backfill has been done by Dixon et al. (2008a, b; 2011a, b) and Rikonen (2009), but these tests involved extruded

bentonite pellets. As part of the joint pellet project activity, water uptake, density and radial and axial pressure development have been evaluated by VTT in their test cell having dimensions of 470 mm height by 360 mm outer diameter. These tests simulated the 50 mm outer gap associated with the container and the surrounding rock in the IFB geometry. The test layout is provided in Figure 22 together with a photo showing the results of one of these tests.

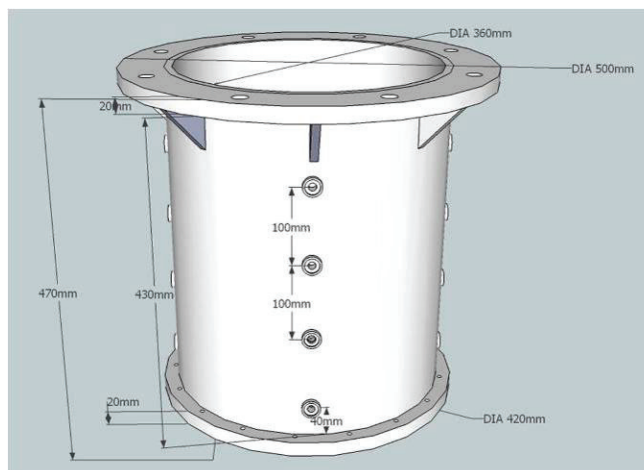

(Photos from VTT)

Figure 22: Test Chamber (upper) and Artificial Wetting of Pellet Fill in the IFB Geometry (lower)

Wetting tests are continuing at VTT as part of their work on water uptake and swelling in an IFB geometry where pellets have been used. This work includes evaluation of all six of the large batches of pellets produced by AECL for Posiva/SKB as well as customized extruded bentonite pellets, Cebogel pellets and the Buffer Test roller compacted bentonite materials. The results of these tests will be included in the pellet optimisation report to be published by Posiva on completion of their project work in early 2013.

5. RESULTS OF PELLET TESTING

5.1 VISUAL CHARACTERISATION

As each of the batches of pellets was produced they were visually inspected and any unusual features were recorded (e.g. incomplete formation of pellets (Figure 23), high fragility (Figure 23), presence of webbing between pellets (Figure 16), or other surface defects as shown in Figure 23). A summary of some of these observations are provided in the Tables of Appendix B.

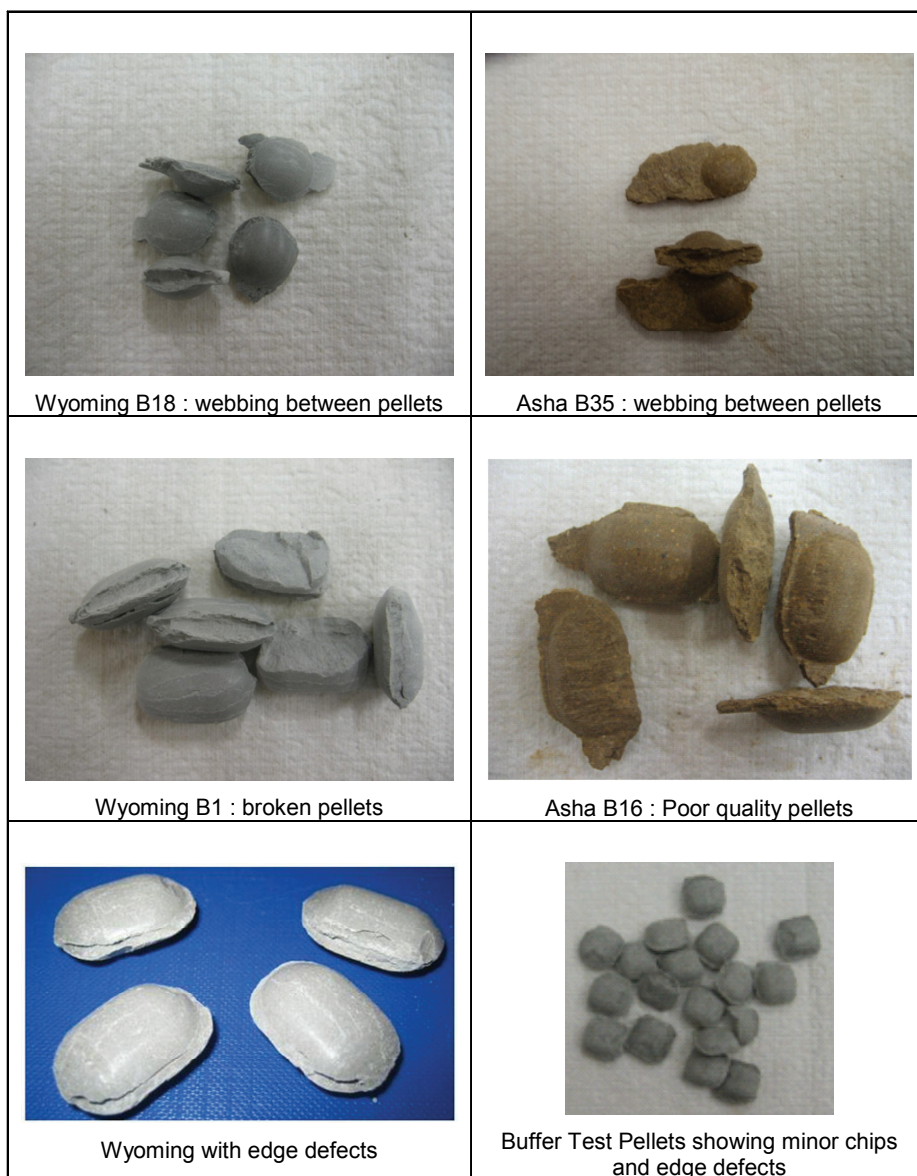

Figure 23: Types of Defects Observed in Pellets (most resulting from moisture content of feed material)

One of the pellet types (Batch 56 consisting of large 100%Wyoming bentonite pellets) manufactured showed small defects and longitudinal surface cracks along the seams where the two halves of the rollers met during pellet manufacture. The strength and durability of these pellets was high so it was subsequently produced as one of the large batches that were sent to VTT where it was subjected to a more detailed surface analysis, pouring trials and abrasion testing. Other batches that were produced in large quantities for more extensive testing did not show the type of surface defects.

The nature of the longitudinal defects in Batch 56 were evaluated using optical microscopy. A Wild M8 stereo microscope with a QWin image analyzer was used. Figure 23 and Figure 24 show examples of the visual and microscopy images obtained. It was determined that all of the pellets were similar, with a substantial number of the pellets exhibiting some degree of cracking. The cracking did not appear to hinder performance with respect to strength or swelling. It is expected that in the future the cracking could be avoided by further optimising the material feed and roller compacting process.



a) AECL pellets, height of photo 11mm.

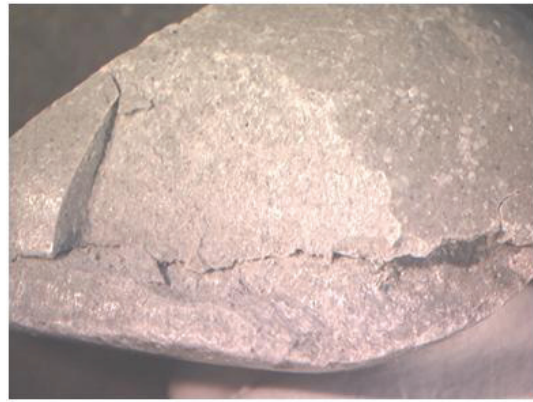

b) Finland pellets, height of photo 11mm.

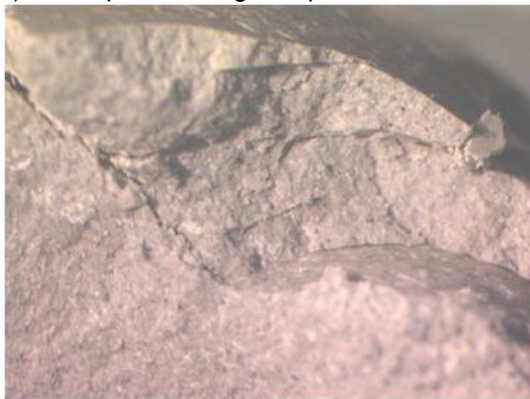

c) AECL pellets, height of photo 4 mm.

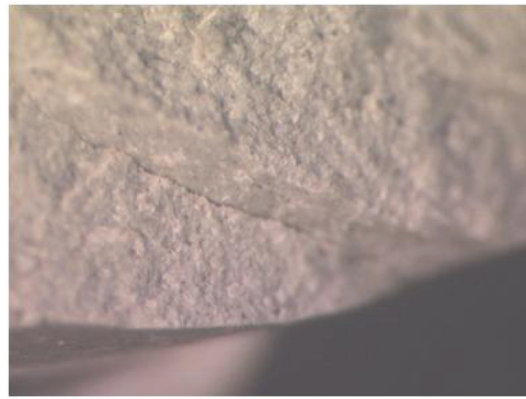

d) Finland pellets, height of photo 4 mm

Figure 24: Microscopic Images of Large Pellets showing Nature of Surface Defects

5.2 PELLET DENSITY

Using the technique described in Section 4.4.3, each of the pellet types manufactured in the course of this study had their dry and bulk densities determined. Table 9 presents the results of these compaction trials on bentonite-only as well as bentonite-sand and bentonite-illite blends. Table 10 provides the data related to clay-only pellets. As shown in the tables, these pellets produced at the AECL's Geotechnical Laboratory have higher dry density than commercially available bentonite pellets ($1.9 - 2.1 \text{ Mg/m}^3$ versus $1.7-1.8 \text{ Mg/m}^3$). From these data it is possible to begin the process of assessing what effect adding a more thermally-conductive component to bentonite clay has on the ability to produce durable pellets or various sizes.

From the large number of compositional and size options examined in the first stage of the material screening testing, a smaller number of the most-promising material compositions and sizes were identified based in their observed physical durability and preliminary strength evaluations. The most promising materials were then manufactured in larger quantities and these larger batches were subsequently used for larger-scale placement density and durability evaluations.

The pellet density results in Table 9 and Table 10 are presented in Figure 25 (clay-only) and Figure 26 (clay-filler blends) and from these data the effects of each additive were evaluated. In these plots, the pellets are classified by their size with S=Small (disc 9 mm diameter x 6 mm thick); M=Medium (oval 22 mm long x 11 mm wide x 7 mm thick); L=Large (oval 22 mm long x 14 mm wide x 8 mm thick).

In Figure 25a a weak trend existed towards increased pellet density in the smaller pellets relative to the larger sizes. This increase in dry density is less than 5% in the materials examined, not a particularly substantial improvement. Similarly there is an indication that there may be a reduction in the achievable dry density with increasing gravimetric water content; again this represents only a <10% difference when the gravimetric water content of the feed material goes from ~6% to ~15%. The trend for reduced pellet density with gravimetric water content increase was also associated with increasing difficulty in producing pellets with the roller compactor as water content increased. It was noted that over the range examined, there was relatively little effect of feed moisture content on the density of pellet produced, although the ease with which they can be produced decreased with increasing water content. This, if confirmed, indicates that there is a considerable range of acceptable moisture contents that can be tolerated during production, making feed material moisture control less important.

When compaction data are presented as gravimetric water content versus Effective Montmorillonite Dry Density (EMDD) in Figure 25b and Figure 26b, the data trends observed for the dry density plot remain and are slightly clearer. What is notable however is, that despite similar dry density values, the EMDD of the Milos B pellets relative to the other materials manufactured by AECL. This is associated with the lower smectite content of the Milos B (~60% versus >75% for the other clays). The lower EMDD values mean that at the same dry density, these materials would develop a lower swelling pressure than pellets manufactured using the other materials. The relationship between hydraulic conductivity (and swelling pressure) and EMDD is presented in detail by Dixon et al. (2011b). It should be noted that this reduction in swelling pressure is not necessarily significant with respect to the ability of the pellets to fulfill their function since

they would still retain a substantial swelling capacity (see Section 5.3). Figure 25 also shows the density values measured for the pellets supplied by Posiva and SKB (Cebogel, Buffer Test, SKB MX-80). These pellets appear to be of slightly (~10%) lower density than those manufactured by AECL. These lower densities are likely related to differences in manufacture (extruded Cebogel) and manufacturing technique (size, manufacturing technique and perhaps water content).

In Figure 26 the results of compaction trials using fine-grained silica sand and illite additions to Wyoming bentonite are plotted. Previous trials evaluating admixtures (see Section 3) determined that the addition of sand to bentonite resulted in substantial improvement of the thermal conductivity of precompacted bentonite-based materials but materials such as copper were not particularly practical. Crushed illitic shale has subsequently been evaluated since it has a substantially higher thermal conductivity than bentonite. It is also a material often found as a minor constituent in bentonite so it should be compatible and it might provide a medium that could provide some resistance to bentonite movement over both the short- and longer-terms. Figure 26 also indicates that there is a trend for increased pellet dry density as the silica sand component increased from 0 to 50% of the dry mass proportion of the pellets. Addition of illite to the bentonite did not seem to affect the compaction characteristics of the pellets and all mixes generally showed similar degrees of compaction. When these same data are viewed with respect to their EMDD some more substantial and systematic differences become evident.

For bentonite-silica sand blends, 10% silica had no discernible effect on the EMDD. At 25% silica content, a very slightly reduction of the EMDD relative to bentonite-only is evident. At 50% silica content, there is a very substantial reduction of the EMDD of the pellets. This indicates that the improved compaction characteristics (higher achieved dry density) for the 10-25% sand component did not result in a reduced EMDD, these mixing ratios therefore seem to be potentially useful if the pellets prove to be thermally superior to the clay-only materials (evaluated in Section 5.7), or other advantages to their use exist. At 50% sand content, the pellets produced are inferior with respect to their EMDD and have some issues regarding their mechanical durability (Section 5.6).

The addition of illite to the bentonite clay resulted in a reduction in the EMDD of the pellets as would be expected in a material where the blending did not accomplish any improvement to the dry density achieved during compaction (Figure 26). Therefore, unless the addition of illite results in an improvement of some other key behavioural parameter (e.g., thermal conductivity, erosion resistance (Sections 5.6, 5.7)), this material is not particularly helpful. The adjacent materials will however have less volume available to swell into than would be present in an unfilled situation, resulting in a higher overall buffer/backfill density than would otherwise be present.

Table 9: Pellet Densities for Wyoming Bentonite and Bentonite-filler Materials Evaluated for Potential Suitability for use in Gap Filling

Material Composition	Batch Number	Pellet Size	Roller Load (psi)	Gravimetric Water Content, (%)	Bulk Density Averages, (g/cm ³)	Pellet Dry Density ρ_d , (g/cm ³)	EMDD (g/cm ³)
100% Wyoming	1	L	1000	6.2	2.07	1.95	1.79
100% Wyoming	2	L	1500	6.5	2.13	2.00	1.85
100% Wyoming	2010	L	1450	9.7	2.13	1.96	1.81
100% Wyoming	3	L	1750	7.1	2.16	2.02	1.87
100% Wyoming	2010	L	1800	9.5	2.15	1.95	1.79
100% Wyoming	43	M	1500	9.6	2.09	1.91	1.76
100% Wyoming	18	S	1500	7.4	2.24	2.08	1.94
100% Wyoming	51	S	1500	9.7	2.18	1.99	1.84
100% Wyoming	29	S	1500	14.9	2.25	1.96	1.81
100% Wyoming	20	S	1750	7.3	2.28	2.11	1.98
100% Wyoming	28	S	1750	13.8	2.30	2.02	1.85
10% quartz sand	4	L	1500	5.8	2.16	2.04	1.84
10% quartz sand	47	M	1500	7.5	2.19	2.04	1.84
10% quartz sand	24	S	1500	5.6	2.32	2.20	2.04
10% quartz sand	30	S	1500	13.7	2.36	2.08	1.89
25% quartz sand	5	L	1500	5.6	2.19	2.07	1.77
25% quartz sand	45	M	1500	6.1	2.20	2.07	1.77
25% quartz sand	25	S	1500	4.6	2.27	2.17	1.91
25% quartz sand	54	S	1500	7.1	2.27	2.12	1.84
25% quartz sand	31	S	1500	14.3	2.35	2.06	1.76
50% quartz sand	48	M	1750	3.9	2.29	2.20	1.72
50% quartz sand	40	S	1750	3.6	2.04	1.97	1.38
10% Illite	6	L	1500	5.2	2.14	2.03	1.82
10% Illite	7	L	1750	5.3	2.13	2.02	1.81
10% Illite	46	M	1500	7.8	2.15	1.99	1.78
10% Illite	26	S	1500	4.9	2.41	2.30	2.16
10% Illite	32	S	1500	14.3	2.21	1.93	1.71
25% Illite	8	L	1500	4.1	2.10	2.02	1.70
25% Illite	9	L	1750	4.3	2.18	2.09	1.79
25% Illite	44	M	1500	4.7	2.05	1.96	1.62
25% Illite	27	S	1750	3.9	2.18	2.07	1.76
25% Illite	33	S	1750	13.9	2.20	1.93	1.59
25% Illite	53	S	1000	10.2	2.23	2.02	1.70
50% Illite	49	M	1500	5.6	2.09	1.98	1.38
50% Illite	50	M	1750	5.6	2.21	2.09	1.53
50% Illite	38	S	1500	4.6	2.22	2.12	1.57
50% Illite	39	S	1750	4.6	2.23	2.13	1.59

Notes: S=Small = disc 9 mm diameter x 6 mm thick. M=Medium = oval 22 mm long x 11 mm wide x 7 mm thick, L=Large = oval 22 mm long x 14 mm wide x 8 mm thick

Table 10: Densities Achieved for Individual Clay-only Pellets Evaluated as a Potential Component in Tunnel Backfill

Material	Batch Number	Pellet Size	Roller Load (psi)	Source Material Water Content (%)	Pellet Gravimetric Water Content, (%)	Bulk Density averages, (g/cm ³)	Pellet Dry Density ρ _d (g/cm ³)	EMDD (g/cm ³)
100% Wyoming	1	L	1000	as-is: 7.0	6.2	2.07	1.95	1.79
100% Wyoming	2	L	1500	as-is: 7.0	6.5	2.13	2.00	1.85
100% Wyoming	2010	L	1450	as-is: 9	9.7	2.13	1.96	1.81
100% Wyoming	3	L	1750	as-is: 7.0	7.1	2.16	2.02	1.87
100% Wyoming	2010	L	1800	as-is: 9	9.5	2.15	1.95	1.79
100% Wyoming	43	M	1500	as-is: 8.4	9.6	2.09	1.91	1.76
100% Wyoming	18	S	1500	as-is: 7.6	7.4	2.24	2.08	1.94
100% Wyoming	51	S	1500	as-is: 10.7	9.7	2.18	1.99	1.84
100% Wyoming	29	S	1500	15.9	14.9	2.25	1.96	1.81
100% Wyoming	20	S	1750	as-is: 7.6	7.3	2.28	2.11	1.98
100% Wyoming	28	S	1750	15.9	13.8	2.30	2.02	1.85
Milos AC200	41	L	1000	as-is: 10.8	11.6	2.05	1.83	1.70
Milos AC200	36	S	1000	as-is: 11.8	11.7	2.08	1.87	1.74
Asha	12	L	750	as-is: 14.2	13.1	2.09	1.85	1.58
Asha	13	L	1000	as-is: 14.2	12.9	2.18	1.92	1.66
Asha	16	L	1250	as-is: 14.2	13.0	2.22	1.97	1.72
Asha	34	S	1250	dried to 9.4	8.6	2.24	2.07	1.84
Milos B	10	L	1000	as-is: 18.0	15.1	2.19	1.91	1.64
Milos B	22	S	1000	as-is: 15.2	13.5	2.24	1.97	1.72
SKB MX80					8.8	2.00	1.86	1.69
Buffer Test - MX80 *					14.9	2.06	1.79	1.62
Cebogel Extruded *					15.6	2.07	1.80	1.60

* Pellets were supplied by Posiva and SKB and differ in size from AECL-produced pellets

S=Small = disc 9 mm diameter x 6 mm thick

M=Medium = oval 22 mm long x 11 mm wide x 7 mm thick

L=Large = oval 22 mm long x 14 mm wide x 8 mm thick

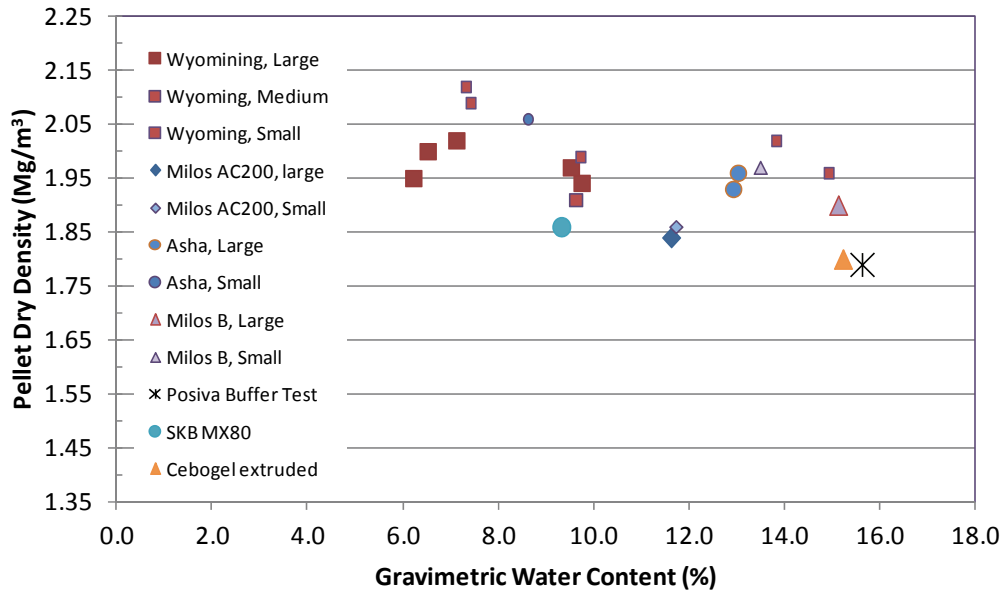

(a) Dry Density – Gravimetric Water Content

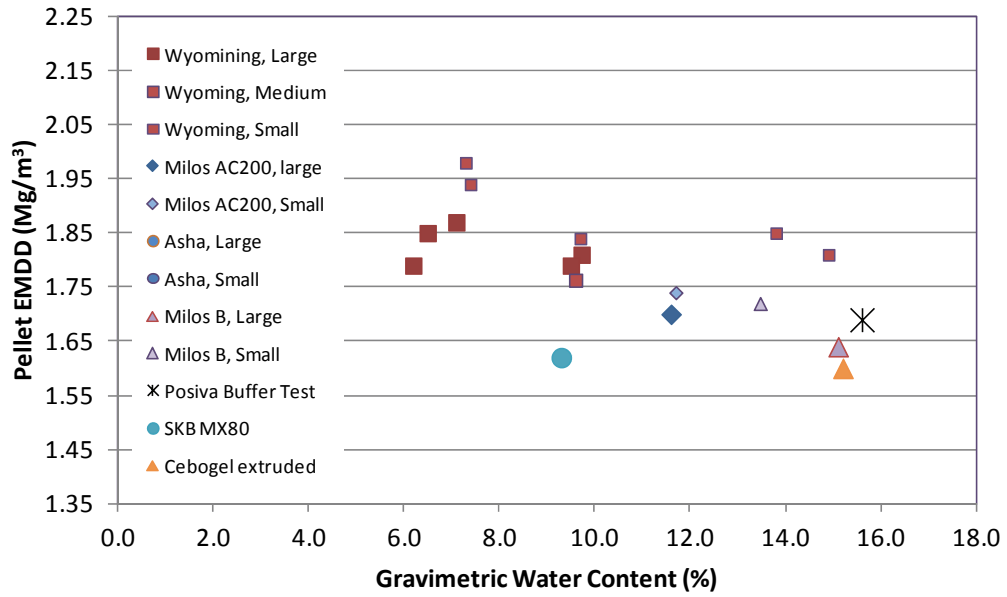

(b) EMDD – Gravimetric Water Content

Figure 25: Effects of Clay Type and Pellet Size on Dry Density and EMDD

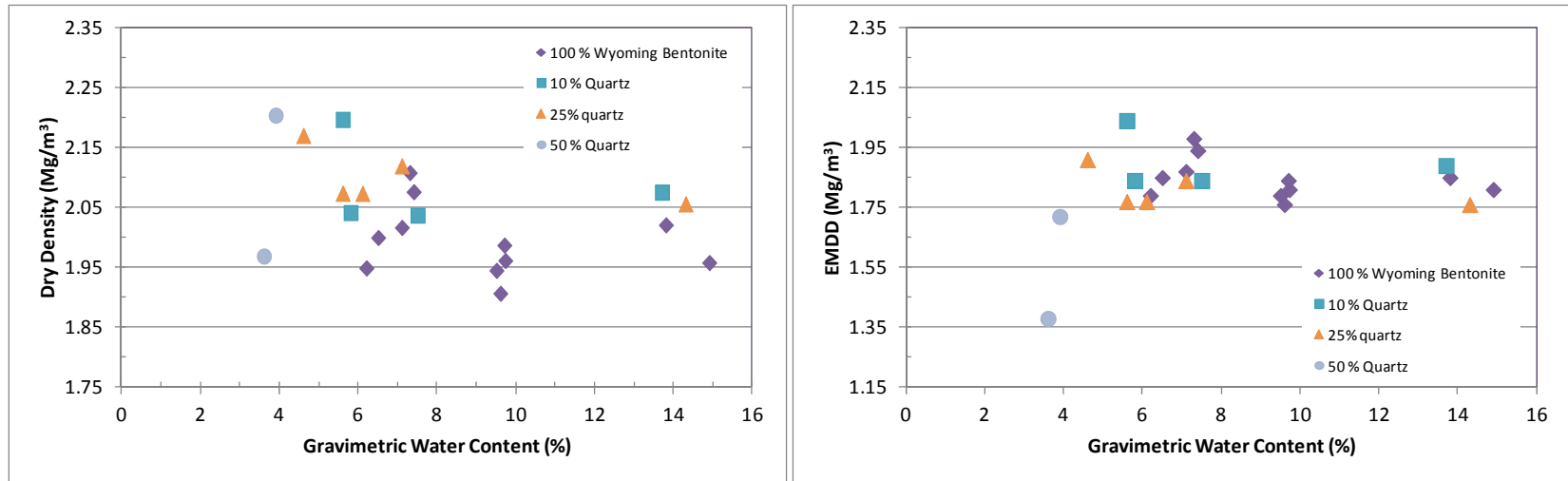

Bentonite – Silica Sand Blends : Dry Density and EMDD of Pellets

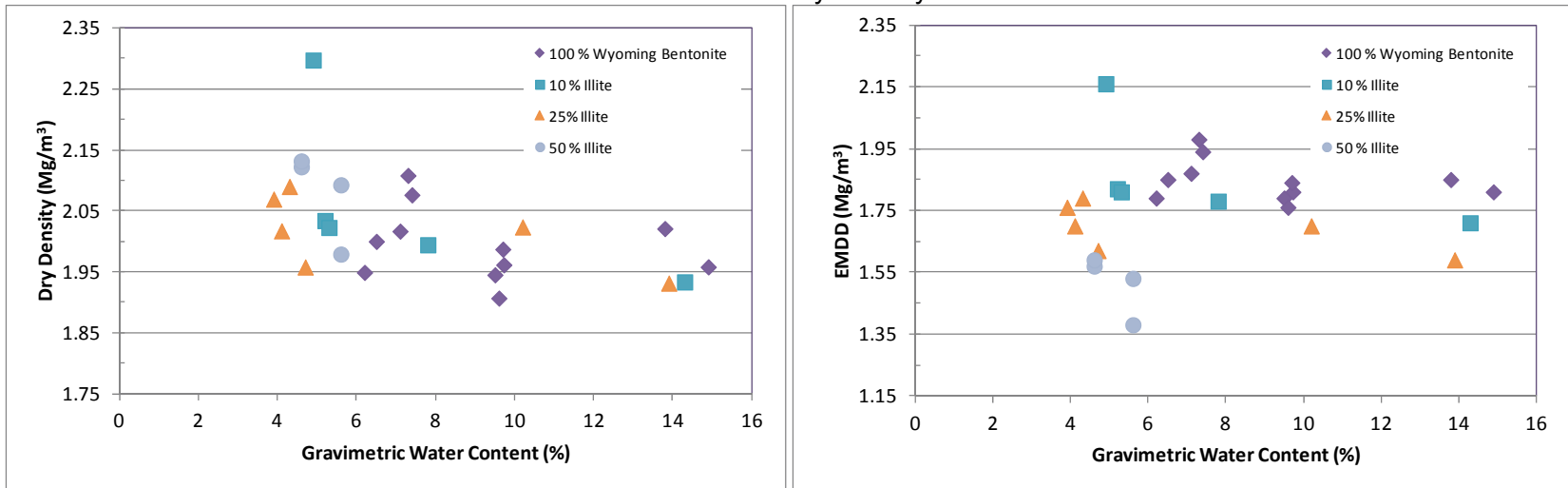

Bentonite-Illite Blends: Dry Density and EMDD of Pellets

Figure 26: Effects of Pellet Composition Dry Density and EMDD of Wyoming Bentonite-Based Pellets

5.3 FREE SWELL TESTS

The method used to determine the free swell capacity of each of the pellets manufactured in the course of this study was briefly described in Section 4.4.3. For each of the water salinities evaluated in this study (0, 35, 70, 160 and 270 g/L Total Dissolved Solids, TDS), a free swell test was conducted. For comparison purposes the materials supplied by Posiva and SKB were also tested to determine their free swell capacity under fresh water conditions. The detailed results of these tests are provided in the tables in Appendix B and these data are plotted in Figure 27 and Figure 28.

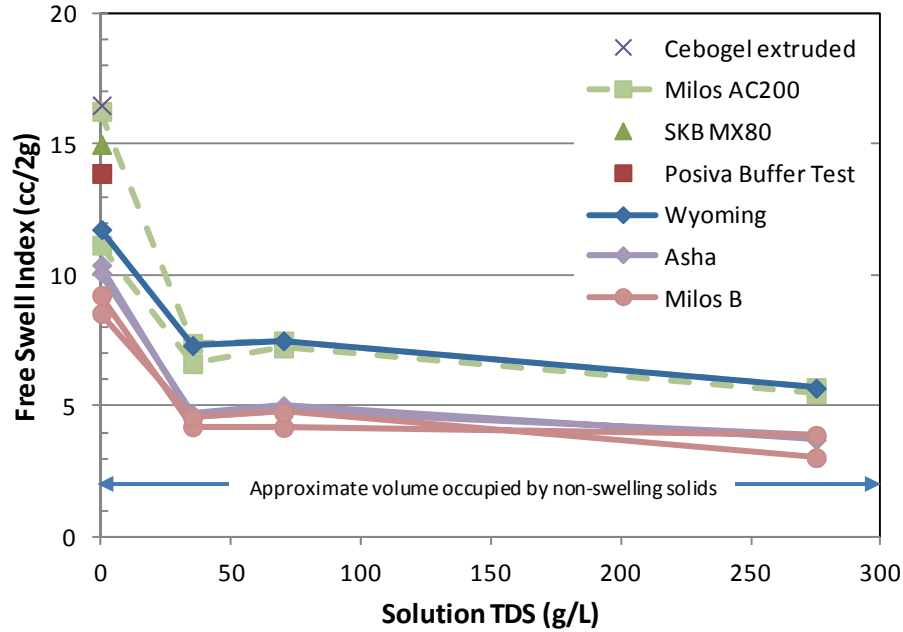

Figure 27: Free Swell Capacity of Bentonite Clay Pellets and Effect of Solution Salinity

Figure 27 shows that as per Table 4, two basic qualities of bentonite were examined in this study. The high montmorillonite-content Wyoming, Milos AC200 and Cebogel materials all contain >75% swelling clay and exhibit substantially higher Free Swell Indices (FSI) than the lower smectite Milos B and Asha clays. This difference becomes particularly evident in the FSI for these materials under high water salinities. The FSI measured for the compacted pellets are compared to the uncompacted source clays in Table 4 and the powdered materials show a much higher FSI than the pellets. This is attributed to the manner in which swelling occurs. In the powdered materials, the clay has no constraints to swelling and will form a low-density gel. The pellet materials must take on water from their surroundings, swell and disaggregate and so have no opportunity to form a gel-like suspension. The FSI values for the powder and pellet materials are consistent with regards to the relative order of volume change (e.g., Cebogel/Wyoming/Milos AC200 > Asha/Milos B), which provides confidence in the ability to compare results for various materials. These tests do however highlight the need to be careful when comparing the results obtained from different forms of the clays (e.g., powder and pellet).

Figure 28 shows the effect of the water chemistry on the ability of the pellets to swell in an unconfined environment. All of the pellets manufactured from swelling clays examined have a substantial swelling capacity under fresh water conditions (8-16 times their initial volume), with materials having the highest smectite (montmorillonite) content showing the highest FSI. As salinity increased to 3.5% TDS, there is a marked reduction in the FSI (4-7 times the initial pellet volume), with the value again being determined by the smectite content. Beyond 3.5% TDS water salinity, there is only a gradual decrease in the FSI of the clays, ultimately at ~27% TDS, the FSI has dropped to between 3 and 6 cm³/2g. It should be noted that the original density of the individual pellets was approximately 2000 kg/m³ (= 1cm³/2g) and for illite and silica materials the FSI is < 2 cm³/2g. Hence a fine-grained, non-swelling material could be expected to have a FSI in the order of 2 cm³/2g. The free swell tests confirm that the pellet materials will disaggregate under the entire range of groundwater salinities examined (0-27% TDS) and will occupy a volume 1.5 to 3 times that of an individual pellet. Most of this additional volume represents the void spaces originally between the pellets (as-placed dry density of pellet mass ~900-1000 kg/m³, is ~0.36 solids and 0.64 voids or a FSI of ~2). The data therefore shows that low smectite content clays have only a very limited swelling capacity at salinities at or above 3.5% TDS and all materials are strongly affected by solution chemistry.

The FSI's measured are consistent with the magnitude of the swelling pressures developed (a measure of ability of bentonite-based material to expand in a rigidly confined environment) for low density bentonite-based materials (Figure 29). For a given dry density, the swelling clay content will therefore decrease in proportion to the quantity of additive present. The FSI of these materials would also be affected by the smectite content of the clay used as well as the EMDD. However in this study clay-additive pellets were all manufactured using Wyoming bentonite as the swelling clay so the smectite content of the clay will have remained constant. The pellets, when poured to fill a gap exhibit as-placed dry densities in the order of 0.9 to 1.1 Mg/m³ for clay-only systems (an EMDD range of ~0.6 to ~0.95 Mg/m³). These densities would result in swelling pressures of 10 kPa (270 g/L, low quality bentonite) to ~400 kPa (freshwater, high quality bentonite) if the clay were confined in a fixed volume.

In the bentonite-additive systems the EMDDs achieved during gap filling were never higher than for the clay-only pellets and in most cases there was a reduction in EMDD values. Therefore with reduced FSI for the mixed component systems, the swelling pressures that could develop will also decrease. The effect of an increased dry density, achieved through vibratory compaction and/or addition of a fines component will improve both the EMDD and hence the swelling pressure developed by the pellet fill under each groundwater condition considered.

Addition of filler materials can therefore be concluded to act as an inert component in bentonite-based pellet materials, which is consistent with the EMDD concept, which treats non-swelling solids in the bentonite as inert fillers also. The volume of the pellets on completion of disaggregation and unconfined swelling is proportional to the smectite content of the clay, the proportion of filler material added and the salinity of the water.

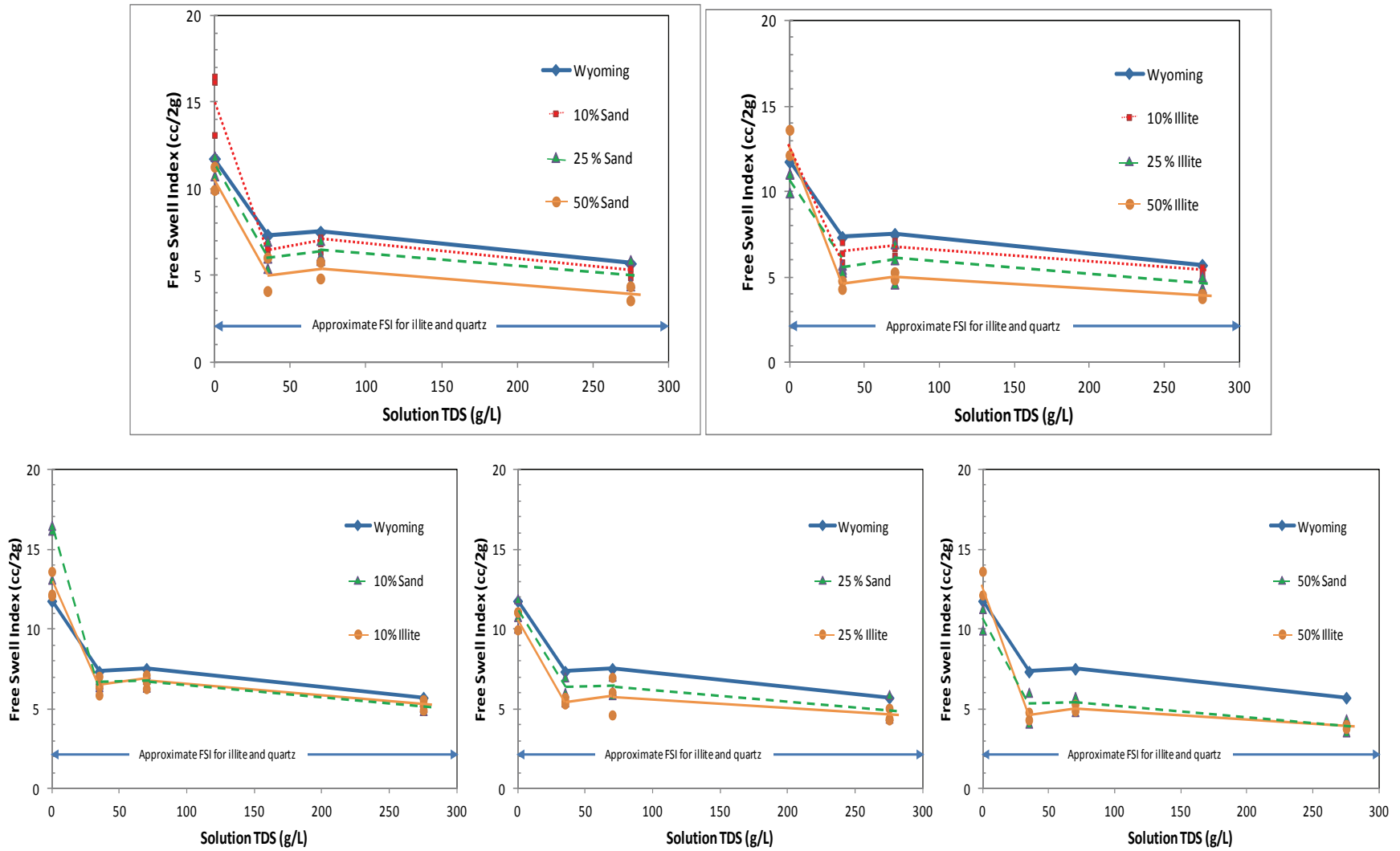

Figure 28: Free Swell Index of Wyoming Bentonite and Blends with Crushed Illitic Shale and Fine Silica Sand

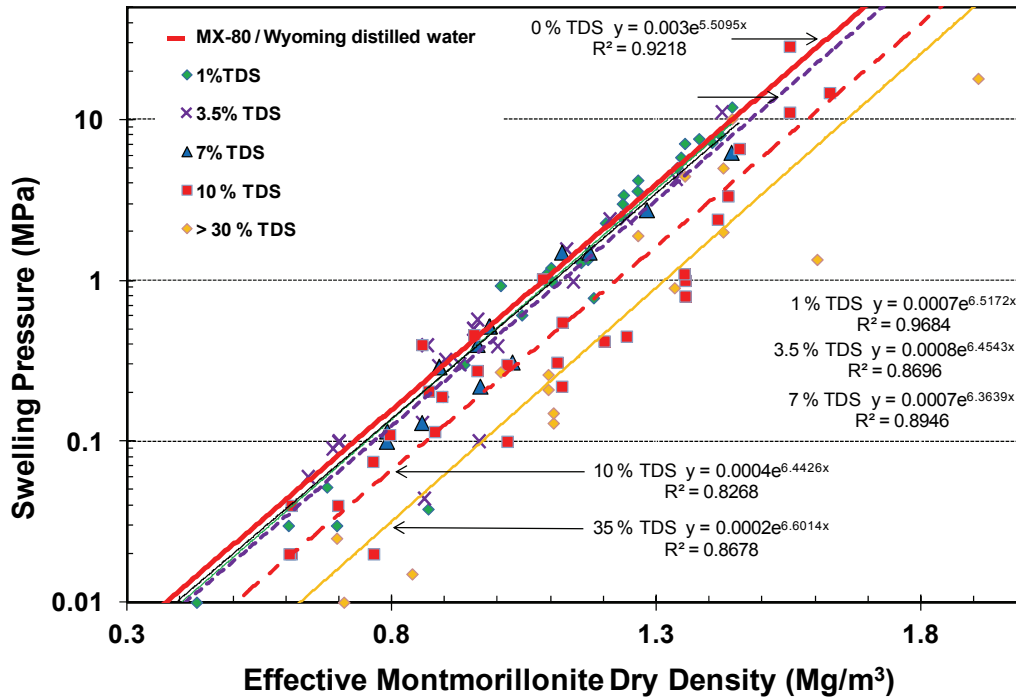

Figure 29: Changes in Swelling Pressures in Bentonite Clays as Result of Water Salinity (EMDD of as-placed clay-only pellet fill ~0.6-0.95 Mg/m³)

5.4 CRUSH STRENGTH OF INDIVIDUAL PELLETS

Mechanical stability is an important parameter for gap fill or backfill materials. These materials must be durable and able to protect adjacent HCB buffer in the period between buffer installation and ultimately borehole closure by completion of backfilling operation in the overlying tunnel. The pellets used in the tunnel backfill or in the HTP geometry need to be able to fill the voids they are placed in without losing their physical integrity and continue to provide their filling and thermal functions in the period prior to water saturation. The strength of individual pellets was evaluated to provide:

- An indication of the effect of pellet composition and manufacturing water content on the material produced by roller compaction, and
- Information on the ability of the individual pellets to retain their physical integrity prior to and during installation.

The results obtained from the crush strength testing were evaluated based on the size and shape of pellets. Figure 30 and Figure 31 show the results of the crush strength tests and these data are provided in full in the tables provided in Appendix B. The first step in evaluation of the data looked at the crush strength values of clay-only pellets produced based on the size and water content. Figure 30 and Figure 31 show plots of crush strength of large pellets and small pellets respectively based on their gravimetric water contents (no medium sized pellets were produced using 100% clay). It should be noted that the values of water content and crush strength shown are the average values obtained by testing several pellets of each type.

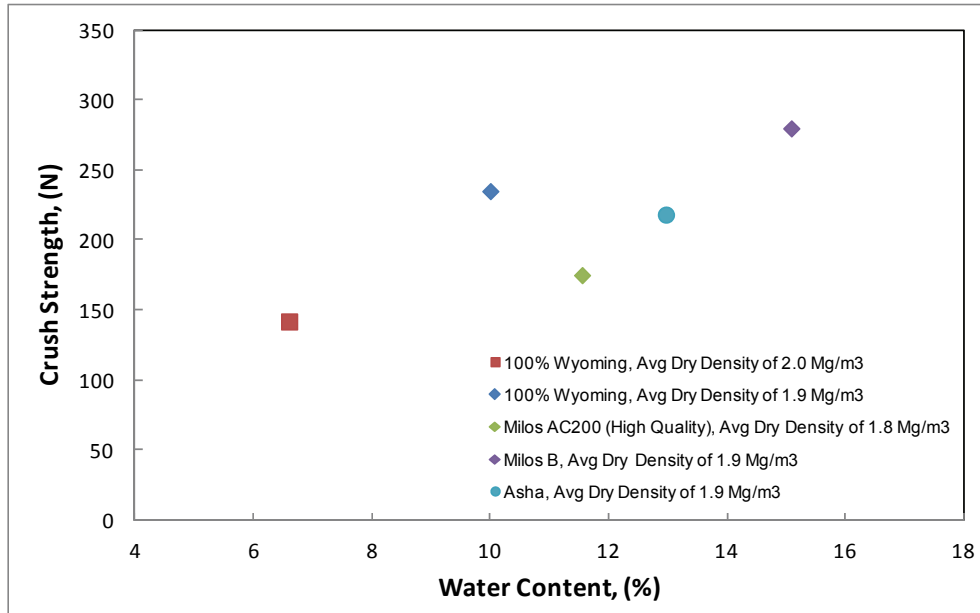

Figure 30: Comparison of Average Crush Strength for Large, Clay-Only Pellets

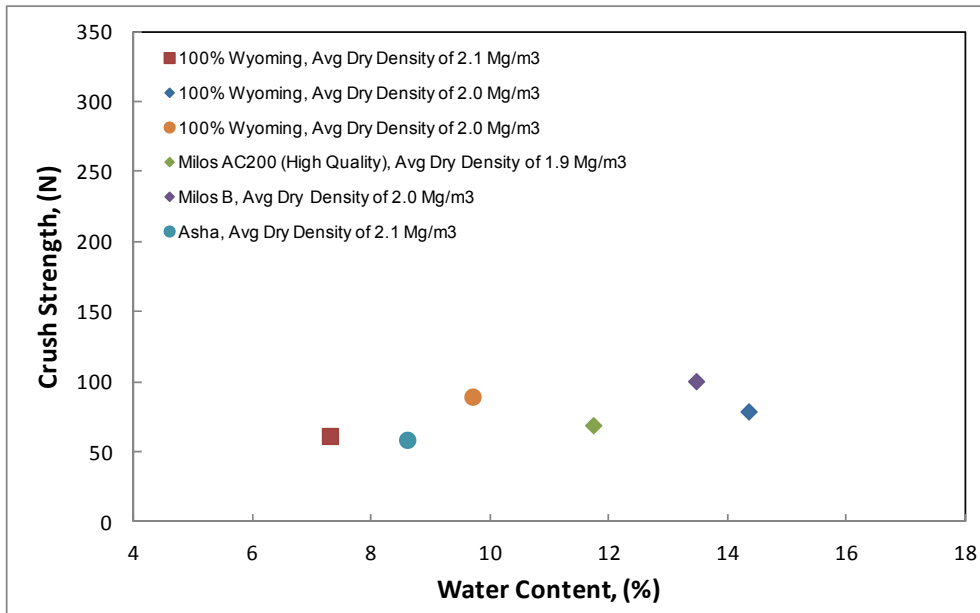

Figure 31: Comparison of Average Crush Strength for Small, Clay-Only Pellets

In addition to the clay-only pellets manufactured using Wyoming bentonite, small batches of large- and small-sized pellets were manufactured using Milos AC200, Asha and Milos B bentonite. These pellets, along with Cebolgel (extruded pellets) and bentonite pellets used in Posiva's Buffer Test project were also tested to determine their crush strength (Figure 32, data provided in Appendix B).

The results of crush tests on clay-only materials can be summarised as follows:

- The large pellets of Milos AC200 and Milos B materials showed ~25% lower and ~20% higher crush strengths respectively as compared with the pellets manufactured using Wyoming bentonite. The Asha pellets were essentially the same as the Wyoming pellets with respect to crush strength.
- Large pellets produced from Milos B clay (lowest smectite content and high water content) showed the highest crush strength (280 N). 100% Wyoming bentonite pellets show strengths of 142 N and 235 N for water contents of 7% to 10% respectively. Asha pellets show a slightly higher strength (approximately 200 N) than Milos AC200 pellets (175 N) at similar water content.
- In general, for the large pellets, there is a trend for increasing average strength with increasing water content for the range examined in this study. Minor differences in the density of the pellets tested accounts for part of the data scatter while compositional differences (montmorillonite content) will also account for some differences in the strength of the various pellets, but these should be secondary effects.
- In some cases when comparing the results of several tests the presence of micro-cracks in the large pellets can explain some of the variation in results observed (Figure 32a).
- For small, clay-only pellets, the trend of increasing average strength with increasing water content found in the large clay-only pellets was not evident. The strength of all the pellets tested ranged from about 50 to 100 N with Milos B pellets showing the highest strength (100 N).
- Comparing the relative strengths of the small pellets showed Asha was the weakest pellet (~20% lower than Wyoming and Milos AC200). Milos B had the highest strength (~20% higher than Wyoming and Milos AC200). The Cebogel and Buffer Test (MX-80) pellets both had substantially higher crush strengths than the small pellets. This is in part due to differences in size and shape relative to the other materials tested, as well as their higher water content (Cebogel 22% and Buffer Test pellets 17%).

As was the case with the large pellets, the parameters of montmorillonite content and range of water content over which pellets could be successfully manufactured have resulted in some of the data scatter but should not have masked any strong trends in behaviour.

The effects of adding a filler material to bentonite clay is an important part of determining what optimisation in pellet composition is realistically achievable. Pellet optimisation is of interest in development of material options for use as gap fill for the IFB geometry, placement tunnel fill in the HTP geometry and, to a lesser extent perhaps for development of pellet materials for use in deposition and central tunnel backfilling using the block and pellet concept. These applications will each require different pellet sizes and have different functional demands on the pellets. In order to try and assess optimisation options relevant to each application, three sizes of pellets were manufactured with 10, 25 and 50 % of fine quartz sand or Illite (by dry weight %) added to a Wyoming bentonite. Exactly the same test procedure as was used to determine the crush strength of the bentonite clay-only pellets was used to determine the strength of these blended materials. For ease of comparison strengths are discussed relative to

pellets of the same size produced from 100% Wyoming bentonite. The compressive load required to fail the individual pellets decreased with decreasing pellet size but for the same size of pellet it will be possible to identify any trends regarding strength that water content or pellet composition may induce.

The results of compressive strength testing of pellets produced from Wyoming bentonite-filler materials as well as other clay products are plotted in Figure 32 so as to show their relative strengths and the variability in the measurements made. Variability was most noticeable in the large pellets, which tended to have slightly more obvious physical variability with respect to micro-cracks. In Figure 33 these data are plotted such that the effects of water content can also be evaluated. The complete set of measurement results is provided in Appendix B.

The effects of blending bentonite with filler materials can be summarised as follows:
In pellets containing silica sand:

For large pellets,

- the addition of 10-25% by dry weight silica sand had essentially no effect on the crush strength.

For medium-size pellets,

- the addition of 10-50% by dry weight of silica sand increased strength ~70%, with maximum densification occurring with a 25% silica sand component,

For small-size pellets

- average strength increased by ~10-20% with a 10% silica sand content;
- at 25% silica sand component, the average strength approximately doubled;
- at 50% silica sand content, the strength of the pellets was less than or equal to what was observed for the 100% clay pellets. At this combination of pellet size and filler component there would appear to be interference of the filler with the compaction process although pellets could still be manufactured.

In pellets containing Illite:

For large pellets,

- With a 10-25% illite component the average pellet strength decreased discernibly, particularly at the 25% level.
- No pellets were manufactured at 50% illite content.

For medium-size pellets,

- For 10-50% illite content, the pellets showed an increase in crush strength of ~10-25% from the clay-only compositions.

For small pellets

- 10-25% illite caused no substantial change in the average strength, and
- 50% illite the strength was only slightly lower than for the clay-only.

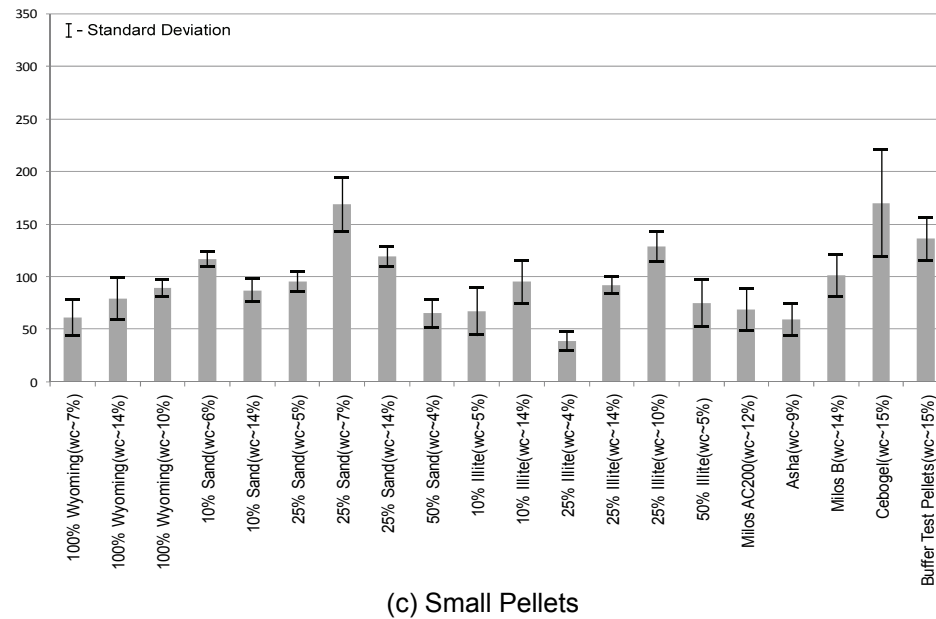
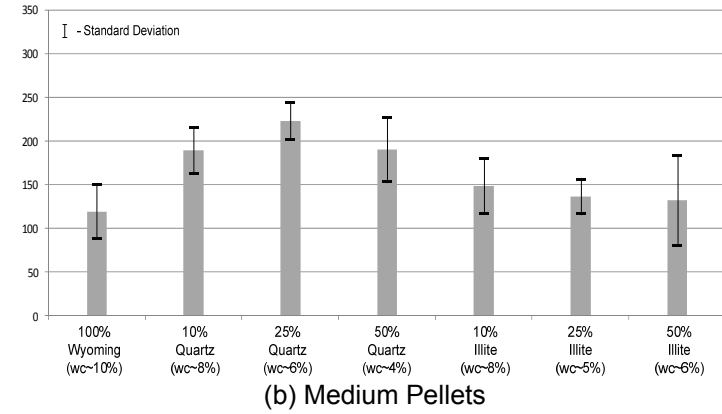
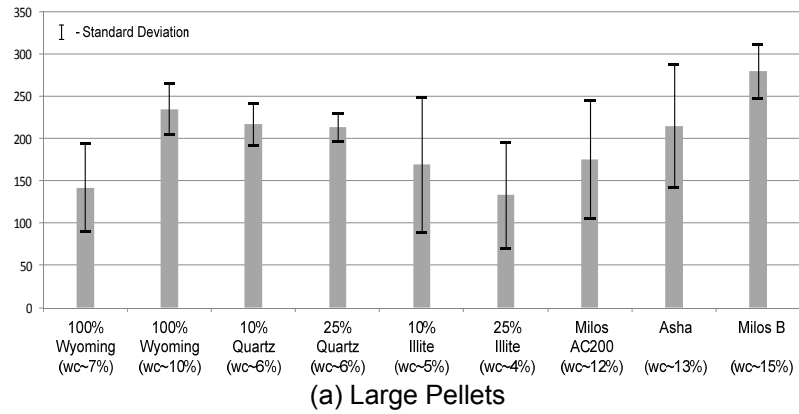
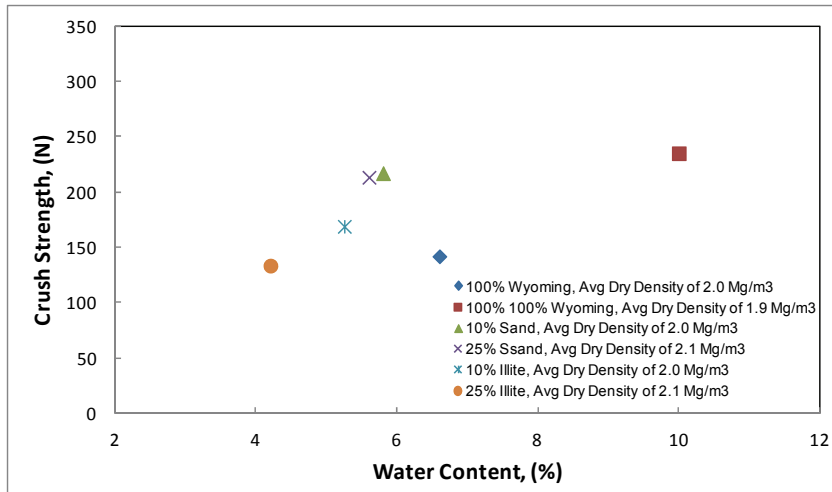
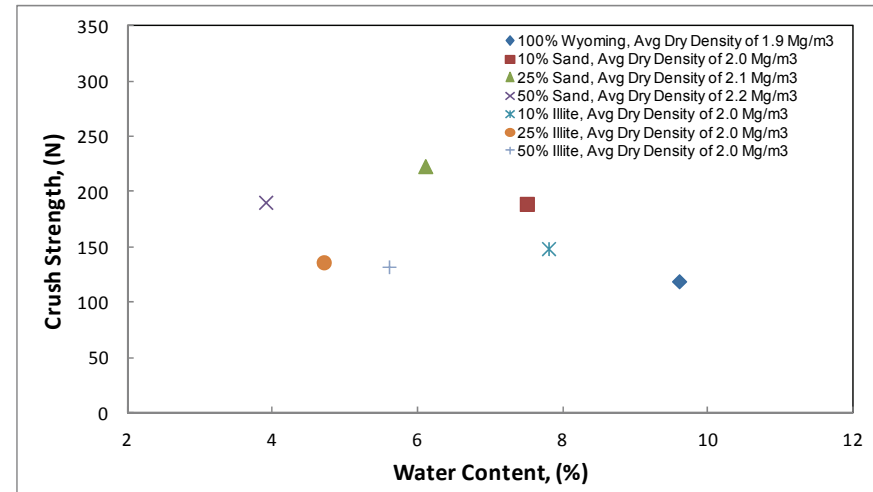

Figure 32: Crush Strength in Newtons (N) of (a) Large, (b) Medium and (c) Small Pellets, showing Standard Deviation of Measurements



(a) Large Pellets



(b) Medium Sized Pellets

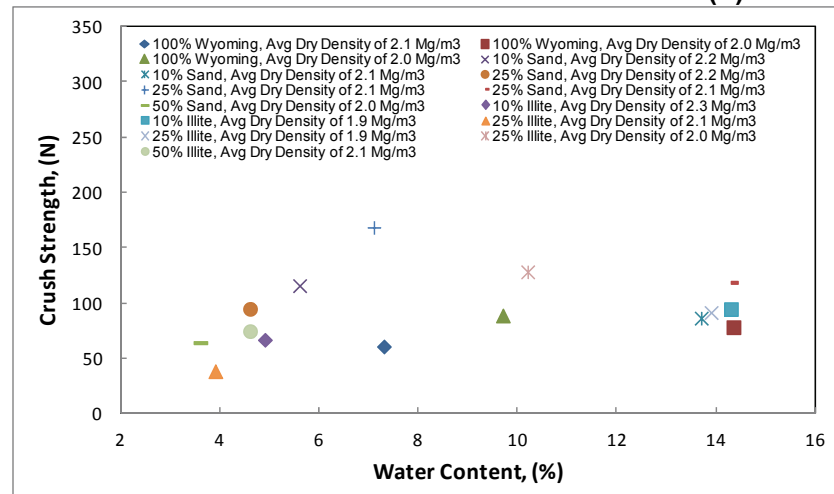

(c) Small Sized Pellets

Figure 33: Comparison of Crush Strengths of (a) Large, (b) Medium, and (c) Small, Clay and Clay – Filler Pellets (Note: the average dry density (ρ_d) of the pellets are provided in the legend of each graph)

5.5 AS-PLACED DENSITY OF POURED PELLETS

The as-placed density of pellet materials used to fill gaps in the IFB geometry or as fill in the HTP or other backfill applications will determine its thermal, mechanical and hydraulic performance in the period immediately following its placement. It will also affect how the fill performs over the longer term. Pellets manufactured in the course of this study were examined to determine what improvement in both as-placed and vibrated densities were achievable and were compared to pellets commercially available.

When comparing the poured and densified (vibrated) bulk and dry densities achieved for the clay-only pellets there is little difference observable for changes in the clay-type used. The average as-placed dry density of poured pellets is approximately 0.96 Mg/m^3 for all of the tests completed (excepting medium sized pellet tests). The large and small pellets do not seem to have a discernible difference in their as-poured dry densities (Table 11 and Figure 34). There are small differences in the bulk (wet) densities achieved but that is entirely the result of pellet water content differences and not any intrinsic change in pourability. It is noted that the medium-sized pellets tended to achieve a poured density that was ~14% higher (1.09 Mg/m^3) than was typically achieved using the small or large pellets. This infers that there is something in their shape/size that improves their loose packing properties. Vibration of the loosely poured pellets always results in an increased density.

Vibration on 100% bentonite pellets resulted in an increased as-placed dry density (maximum 1.34 Mg/m^3) by 24% for medium pellets and by 28% for large pellets. These values of vibrated dry density were slightly higher than those for the commercially available pellets (maximum 1.21 Mg/m^3). However, small pellets of Milos AC200 and Milos B show 12% and 18% increases in their as-placed dry densities (maximum 1.14 Mg/m^3), but these values of vibrated density are still lower than those of commercial pellets.

Pellets produced with a non-bentonite component (10-50 % illite or silica sand), were also evaluated for their poured dry density. These pellets all achieved a slightly (~5%) higher poured density relative to the clay-only materials, consistent with their slightly higher individual pellet densities (Table 12 and Table 13). As with the clay-only pellets, there is a discernible (~14%) improvement in the loose poured density of the medium-sized pellets relative to the small or large pellets but there is no difference in their poured densities relative to the proportion of additive present. This is to be expected since the pellets were all of similar dry density.

The void space was calculated on pellets after completion of as-poured density tests. Table 11 and Table 12 present a summary of poured and vibrated density including values of void space of batches. All the pellets specially manufactured have a range of void space from 60% to 70%. The Milos AC200 pellets had the highest void space of 70% at a water content of ~12% and 25% silica sand had the lowest void space of 60%.

Results of VTT tests (Figure 36) for as-poured density of pellets installed in a long narrow gap were provided for inclusion in this report. As-poured densities of pellets with 100% bentonite, 25% illite, Milos AC200 are close to 1.0 Mg/m^3 , which is very similar to results obtained at AECL. Table 13 presents the results of large-scale pouring trials into long, narrow openings approximating the gap between the buffer and the rock in the IFB geometry. The correlation to AECL results is presented in Figure 37, based on dry

density. This was done because there was a slight loss of moisture between the time the pellets were measured in Canada and Finland (about 1%), as seen from Table 13. These data are also plotted in Figure 36, and show the effect of scale and confined geometry on the loose-poured density achievable using these materials. These are consistent with the types of differences observed in previous pellet pouring and densification trials (see Section 3). Although not done for these trials because of the risk of damaging pellets of limited supply, a vibratory action would increase the as-placed bulk density of the pellet fill (Martino and Dixon 2007, Man et al. 2011, Marjavaara & Kivikoski 2011). The test results for the current study therefore provide conservative bounds for use in analysing the effects of using a pellet fill in the IFB geometry.

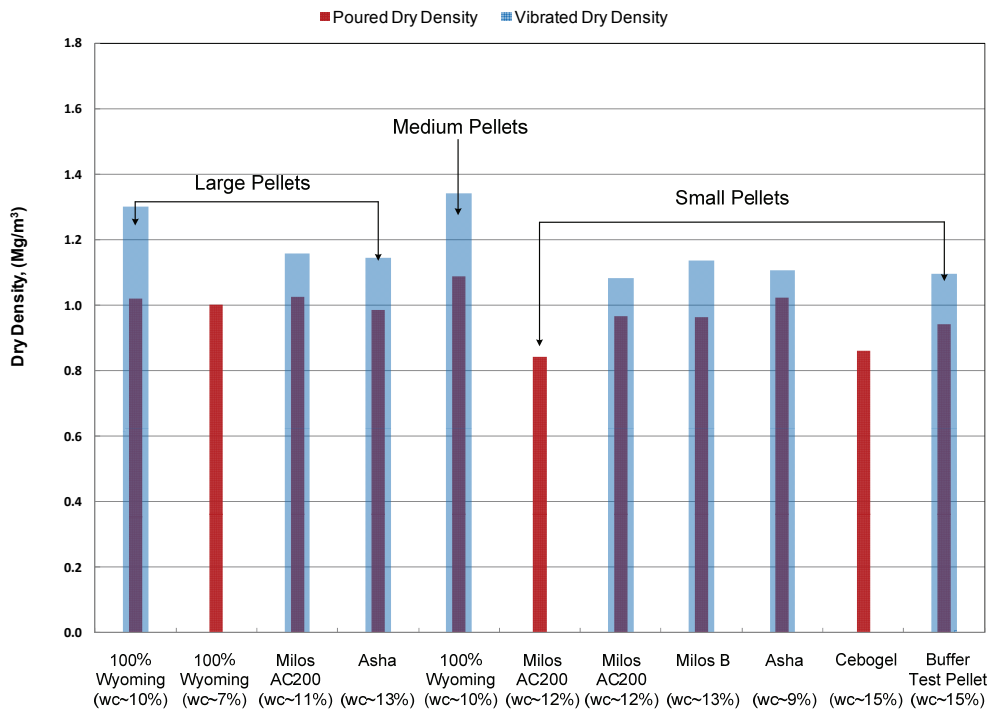
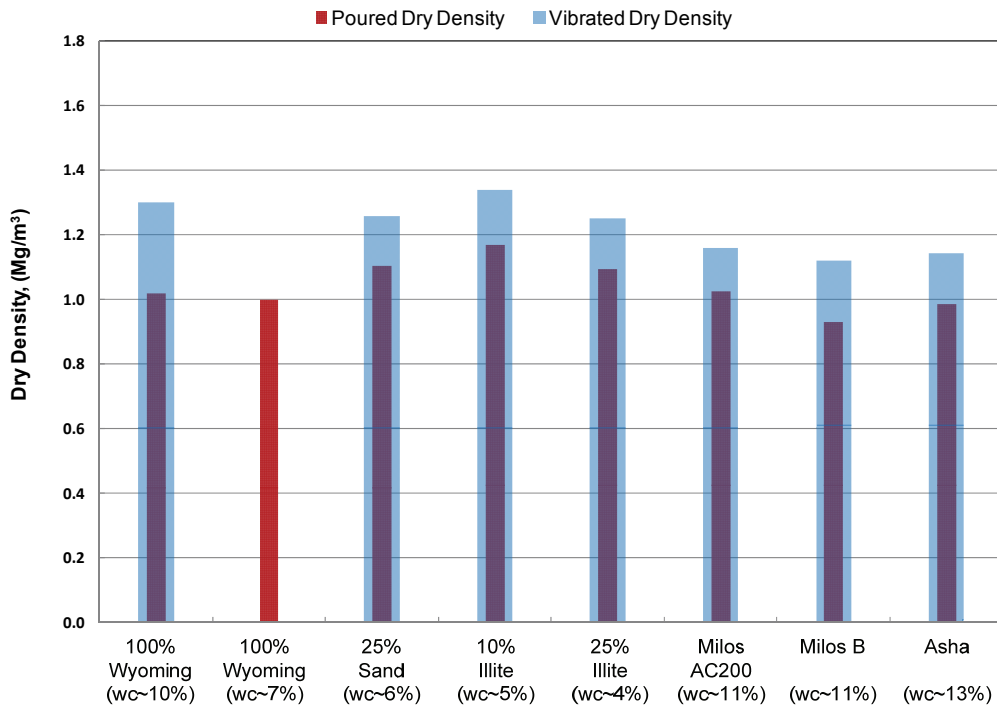
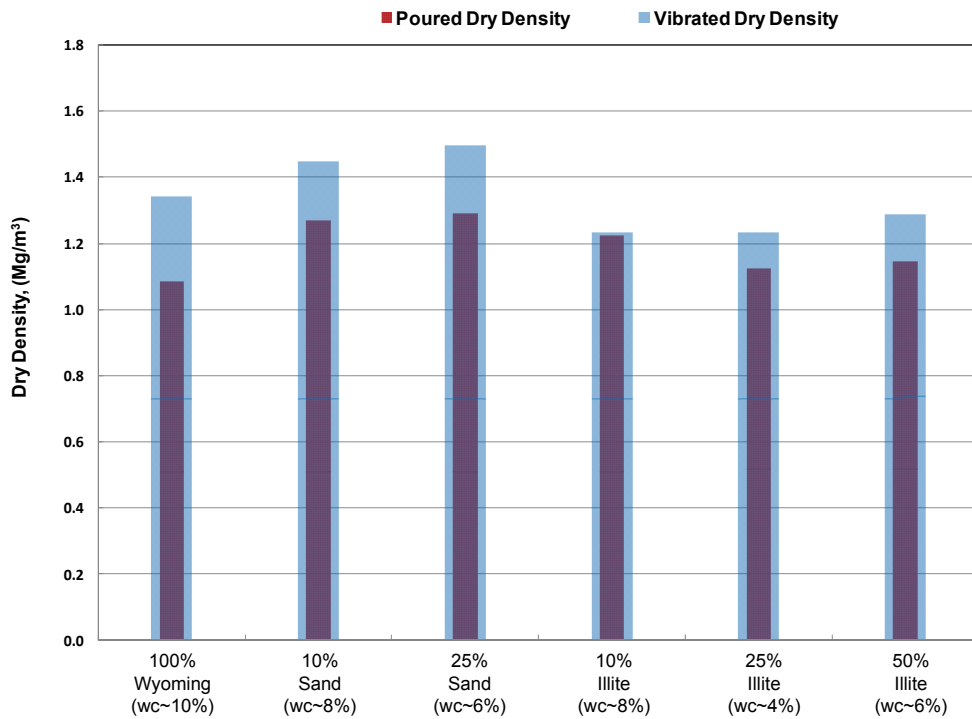

Figure 34: Poured and Vibrated Density of Various Clay-Only Pellets. (Note: two different individual dry densities (1.8 and 1.9 Mg/m³) for Milos AC200 small pellets)



(a) Large Pellets



(b) Medium Pellets

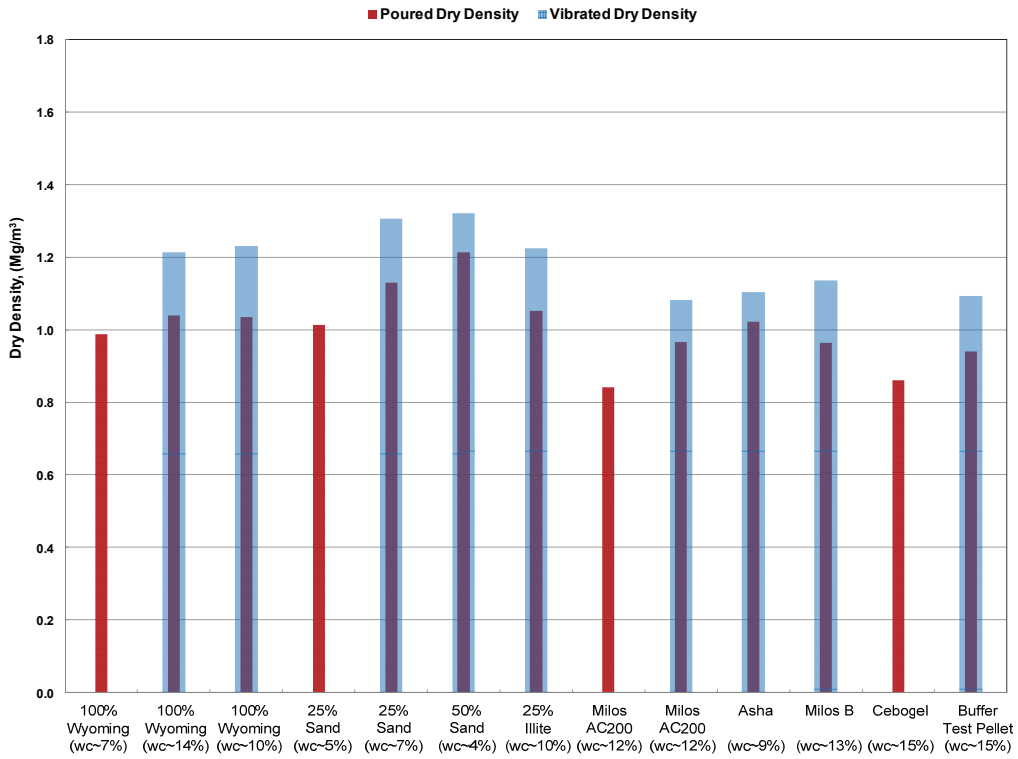

(c) Small Pellets

Figure 35: Poured and Vibrated Dry Bulk Densities of Pellets. (Note: two different individual dry densities (1.8 and 1.9 Mg/m³) for Milos AC200 small pellets)

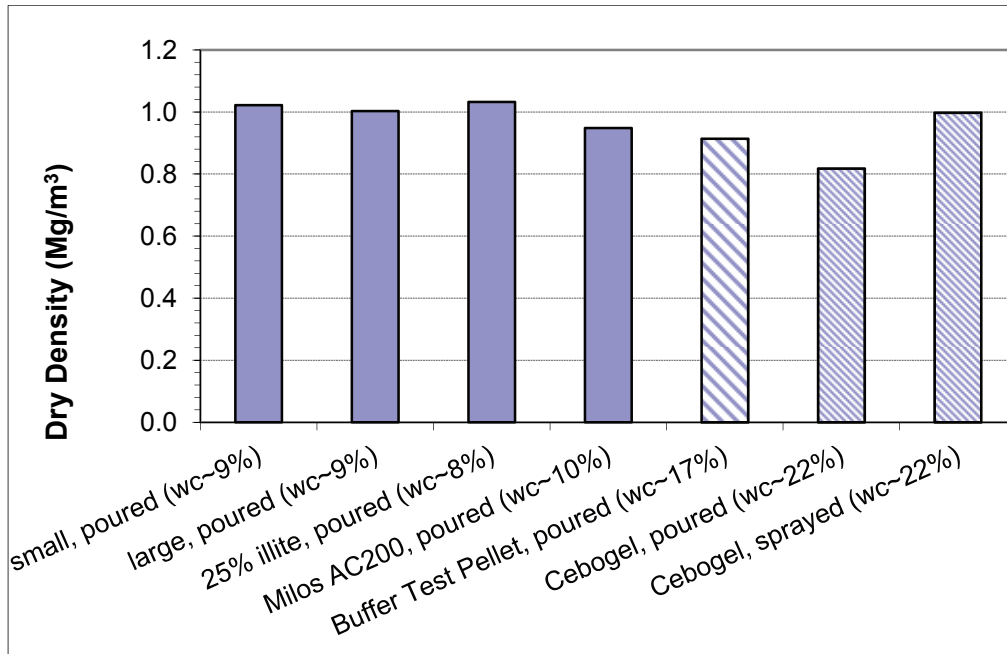

Figure 36: Results of VTT Tests to Determine Loose, As-poured Density of Pellets Installed in a Narrow Gap

Table 11: Poured and Vibrated Densities of Clay-only Pellets

Composition	Batch No.	Size	Water Content %	Single Pellet Bulk Density Mg/m³	Single Pellet Dry Density Mg/m³	As-Placed Bulk Density Mg/m³	As-Placed Dry Density Mg/m³	Vibrated Bulk Density Mg/m³	Vibrated Dry Density Mg/m³
Wyoming	56	L	10	2.11	1.92	1.12	1.02	1.43	1.30
Wyoming	3	L	7.1	2.16	2.02	1.07	1.00		
Milos AC200	41	L	11.4	2.04	1.83	1.14	1.02	1.29	1.16
Asha	17	L	12.9	2.20	1.95	1.11	0.98	1.29	1.14
Wyoming	43	M	9.6	2.09	1.91	1.19	1.09	1.47	1.34
Wyoming	51	S	9.7	2.18	1.99	1.14	1.03	1.35	1.23
Milos AC200	37	S	11.8	2.04	1.82	0.94	0.84		
Milos AC200	52	S	11.8	2.12	1.90	1.08	0.97	1.21	1.08
Asha	35	S	8.6	2.23	2.05	1.11	1.02	1.20	1.10
Milos B	55	S	12.6	2.17	1.93	1.09	0.96	1.28	1.14
Cebogel *			15.2	1.83	1.59	1.05	0.86	1.29	1.12
Buffer Test MX-80 *			15.6	1.79	1.55	1.10	0.94	1.31	1.13
SKB MX80 *			9.3	1.84	1.68	1.09-1.13	0.97	1.24	1.14

* These materials were supplied by Posiva and SKB and were of different size and shape from AECL-manufactured pellets

Table 12: Poured and Vibrated Densities of Pellets Containing Non-bentonite Component

Composition	Batch No.	Size	Pellet Water Content	Pellet Bulk Density	Pellet Dry Density	As-Placed Bulk Density	As-Placed Dry Density	Vibrated Bulk Density	Vibrated Dry Density
			%	Mg/m ³	Mg/m ³	Mg/m ³	Mg/m ³	Mg/m ³	Mg/m ³
100% Wyoming	56	L	10	2.11	1.92	1.12	1.02	1.43	1.30
100% Wyoming	3	L	7.1	2.16	2.02	1.07	1.00	-	-
25% Silica Sand	5	L	5.6	2.19	2.07	1.09-1.16	1.03-1.10	1.27-1.33	1.19-1.26
25% Illite	9	L	4.3	2.18	2.09	1.02	0.98	1.31	1.25
100% Wyoming	43	M	9.6	2.09	1.91	1.19	1.09	1.47	1.34
10% Silica Sand	47	M	7.5	2.19	2.04	1.37-1.49	1.27-1.39	1.56	1.45
25% Silica Sand	45	M	6.1	2.20	2.07	1.29-1.37	1.22-1.29	1.59-1.63	1.50-1.54
10% Illite	46	M	7.8	2.15	1.99	1.32	1.22	1.33	1.23
25% Illite	44	M	4.7	2.05	1.96	1.18	1.12	1.29	1.23
25% Silica Sand	25	S	4.6	2.27	2.17	1.06	1.01	-	-
25% Silica Sand	54	S	7.1	2.27	2.12	1.21	1.13	1.4	1.31
50% Silica Sand	40	S	3.6	2.04	1.97	1.26	1.21	1.37	1.32
25% Illite	53	S	10.2	2.23	2.02	1.16	1.05	1.35	1.23

Table 13: Density and Moisture Content Results from Tests by VTT, Finland

Material	Water Content (%) Production	Water Content (%) Testing	VTT Gap fill, bulk density (kg/m ³)	VTT Gap fill, dry density (kg/m ³)	AECL poured dry density (kg/m ³)
100% Wyoming, small (Batch 51)	9.7	8.9	1112	1021	1110
100% Wyoming, large (Batch 56)	10	8.9	1092	1003	1180
75% Wyoming:25% silica sand, small (Batch 54)	7.1	5.2	-	-	1210
75% Wyoming:25% illite, small (Batch 53)	10.2	8.3	1118	1032	1160
Milos AC200, small (Batch 52)	11.8	10.5	1047	948	1080
Milos B, small (Batch 55)	12.6	9.6	-	-	1070
Cebogel	21.9	21.9	1107	908	1050
Buffer Test MX-80	16.8	16.8	1067	914	993

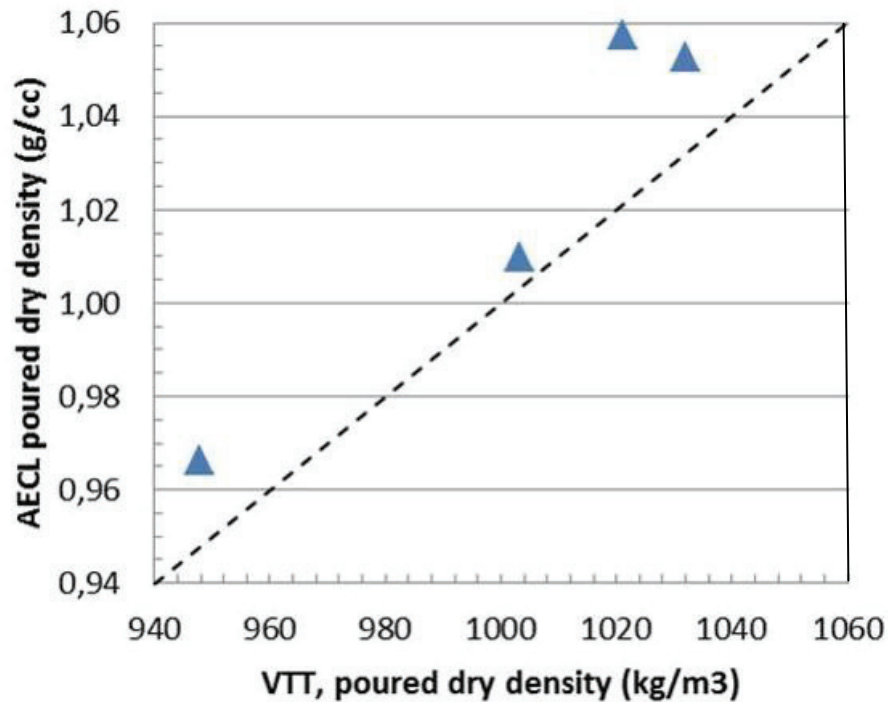

Figure 37: Comparison of Poured Dry Density Achieved in Small-Scale (AECL) and Large-Scale (VTT) Trials

5.6 ABRASION TESTS

Table 14 presents the test results of the abrasion test. The mass loss is presented as the average of two tests. For comparison, Buffer Test pellets and Cebogel extruded pellets were also tested. The table also provides references to standard Finnish aggregates tested in dry conditions (Vuorinen 1999).

Table 14: Results of MicroDeval Test

Sample Name	Mass Loss (%)
Reference: Buffer Test pellets (roller compacted, MX-80)	9.78
Reference: Cebogel extruded pellets	45.95
100 % Wyoming bentonite, small pellets	65.31
100 % Wyoming bentonite, large pellets	16.34
75 % Wyoming bentonite + 25 % Quartz Sand	33.04
75 % Wyoming bentonite 25 % Illite	57.12
100% Milos AC200	38.51
100% Milos B	24.08
Reference Good aggregate A [2] <i>an amphibolite composed of amphibole and feldspar</i>	2.3
Reference Good aggregate B [2] <i>a granite composed mainly of quartz and feldspar</i>	2.3
Reference Weak aggregate C [2] <i>a limestone</i>	8.6

It was expected that there may be some correlation between the wear resistance and strength of the pellets. Material having a higher strength may have better resistance to deterioration (indicated by a low value of mass loss). Table 15 shows the results of both the abrasion resistance and crush strength tests, along with the water contents of the various pellets. Figure 38 shows the relationship between these two parameters for the tested pellets. For equivalent bentonite type and moisture content (Wyoming bentonite with water content 5-9%), the trend held true that pellets with higher crush strength values had lower mass loss (better abrasion resistance). The references Cebogel and Buffer Test pellets had much higher water contents (17-22%) and thus cannot be directly compared to the other pellets. All three bentonites have similar crush strengths, though the mass loss was significantly higher for the 100% Wyoming bentonite compared to Milos AC200 and Milos B.

Table 15: Results of Wear Resistance Tests

Sample	Mass Loss (%)	Crush Strength (N)	Water content (%)
Buffer Test MX-80	9.8	136	16.8
100% Wyoming, large	16.3	235	8.9
Milos B, small	24.1	100	9.6
75% Wyoming + 25% Quartz Sand	33.0	169	5.2
Milos AC200, small	38.5	85	10.5
Cebogel	46.0	170	21.9
75% Wyoming + 25% Illite	57.1	129	8.3
100% Wyoming, small	65.3	89	8.9

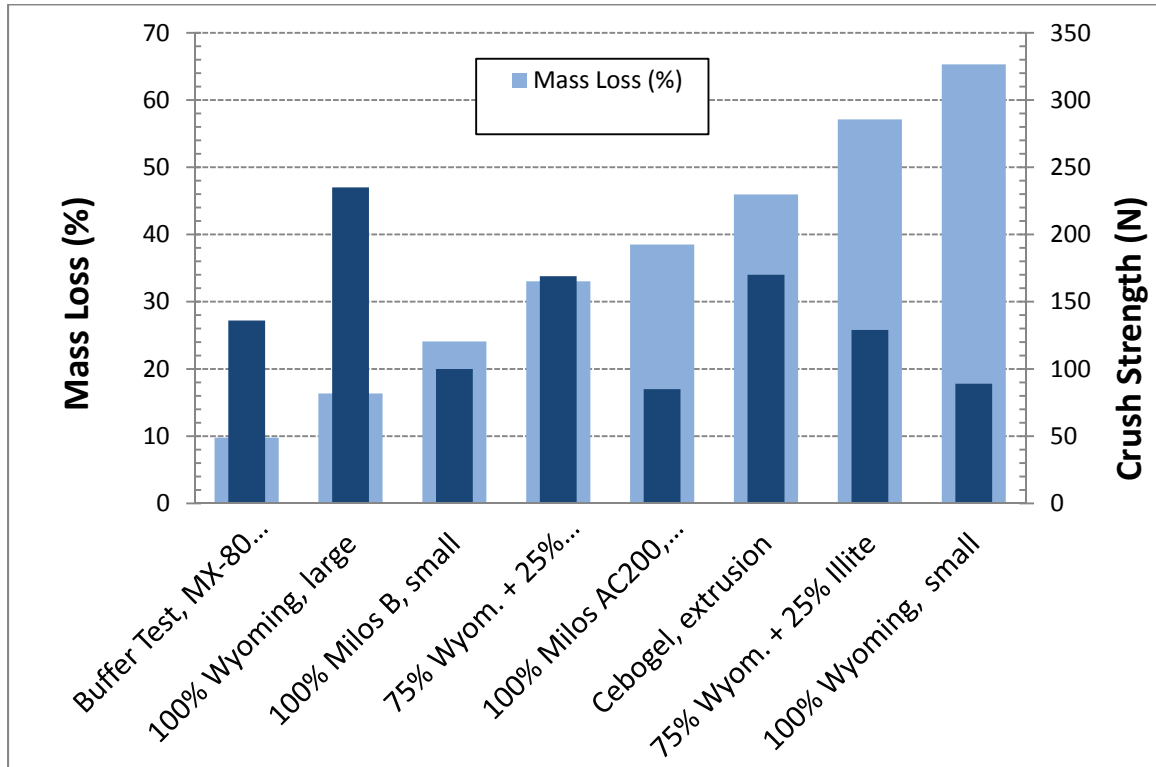

Figure 38: Relationship between Abrasion Resistance (Mass Loss) and Crush Strength

5.7 THERMAL PROPERTIES TESTING

5.7.1 Thermal Properties of Poured and Vibratory-Densified Pellet Fills

The thermal conductivity data for the various pellet-fill materials are provided in Table 16 and plotted in Figure 39. Each point represents the mean of several replicate tests. A pair of points is presented for each type of pellet. The point plotting with lower dry bulk density represents the dry density of the poured mass of pellets and the corresponding thermal conductivity measurement for that condition. The point plotting with higher dry density corresponds to the vibrated mass of pellets and the corresponding thermal conductivity measurement for that condition. Small symbols represent small pellets, medium symbols represent medium pellets and large symbols represent large pellets. Measurements on materials with the addition of Wyoming bentonite fines (i.e., 80 mesh granules) are noted as individual points. The results for large pellets made with 100% Wyoming bentonite are included in all graphs as a baseline comparison.

Figure 39 shows the results of tests conducted on the pellets manufactured during the 2011 program in terms of dry density. Figure 6 showed the results of tests conducted on available commercial pellets tested during the preliminary program and some of this data is repeated in Figure 39 for comparison to the new data set. The complete data set including the measured thermal diffusivity and specific heat values for each type of pellet are provided in Appendix B (Table B-4).

Figure 39(a-e) assists with the evaluation of the effect of vibratory compaction, different sources of bentonite, the addition of additives and different pellet sizes on thermal conductivity of the placed material. Figure 39a shows the results for 100% Wyoming bentonite, and the results for the large pellets are repeated on subsequent plots to provide a visual benchmark for comparison.

The thermal conductivity of loosely poured pellet-fill materials was less than 0.5 W/(m·K) for all of the tested pellets. Densification of the pellet mass using light vibratory compaction increased the thermal conductivity of the pellet-fill material to about 0.6 W/(m·K) for several type of pellets (i.e., the large pellets made with Milos AC200 bentonite, the large pellets made with Milos B bentonite, and the medium sized pellets made with a mixture of 90% bentonite and 10% silica sand). However, this value is still slightly less than the lower end of the desired range of 0.7 to 0.9 W/(m·K). For tunnel backfill or gap fill for use in a repository using the IFB concept, thermal conductivity improvement is also desirable since the option is to leave an air-gap which is much less thermally conductive. As shown in Figure 8, the thermal conductivity of the HCB buffer is also quite low (~0.5 to ~1.1 W/(m·K), depending on density and degree of saturation). Pellet fill of the type tested in this study would therefore be thermally comparable to the HCB buffer. For tunnel backfill applications, thermal properties of the gap fill are of relatively low importance and factors such as mechanical durability, erosion resistance and swelling and hydraulic properties are of greater importance.

5.7.2 Effect of Bentonite Type on Thermal Properties

Different sources of bentonite showed no to slight differences in thermal conductivity (Figure 39b and c). The Milos AC200 bentonite and Wyoming bentonites displayed similar thermal conductivity values. Milos B bentonite displayed a higher thermal conductivity (0.58 W/(m·K) and 0.63 W/(m·K) for small and large pellets after vibratory compaction, respectively), which may be attributed to the higher proportion of more highly heat conductive impurities in this material. Even then, their thermal conductivity is not substantially higher than other pellets. In general, the thermal conductivity of the pellets manufactured during the 2011 program exhibited slightly higher thermal conductivities than the commercially available bentonite pellets (Figure 6).

5.7.3 Effect of Additives to Clay

Comparing the pellets made with a blend of Wyoming bentonite and silica sand to those made with 100% Wyoming bentonite (Figure 39a), little improvement in thermal conductivity is achieved by adding substantial quantities of sand (Figure 39d). The highest thermal conductivity achieved (with a value of 0.61 W/(m·K)) using silica as an additive, was with the medium sized pellets made with a mixture of 90% bentonite and 10% silica. This is only slightly higher than the pellets of the same size made with 100% Wyoming bentonite (0.59 W/(m·K)). It is worth noting that the highest measured thermal conductivity corresponded to the highest density achieved for a mass of pellets. The increase in density due to vibratory compaction results in a greater increase in thermal conductivity than the addition of silica sand to the pellets achieves. Thermal conductivity is therefore dominated by the large air-voids present at the time of installation and modifications to the density of the individual pellets are of secondary importance.

Similarly, the addition of illite did not result in increased thermal conductivity of a mass of pellets relative to the silica-sand materials (Figure 39e). For example, the medium sized pellets made with 75% Wyoming bentonite and 25% illite had a thermal conductivity of 0.53 W/(m·K) (vibrated mass of pellets), which is slightly less than that measured for the same sized pellets made with 100% Wyoming bentonite (0.59 W/(m·K) for vibrated mass of pellets). Higher dry densities were achieved with the addition of illite, but this is at the expense of a lower overall EMDD.

5.7.4 Effect of Pellet Size on Thermal Conductivity

Comparing different sizes of pellets with the same composition, it appears that the medium sized pellets generally produced the highest thermal conductivities. This corresponds to higher densities achieved with the medium pellets relative to the other sizes. Dry densities in the order of 1.4 Mg/m³, which is the target density for NWMO's gap fill material in the HTP geometry, were achieved with the majority of the trials using medium sized pellets.

5.7.5 Effect of Fines Addition

The addition of Wyoming bentonite fines was conducted later in the program in an attempt to further increase the dry density of the placed material and perhaps also

increase thermal conductivity. The fines were in the form of 80 mesh granules, and were vibrated into the larger pores between the pellets. Figure 39a show that the addition of fines to the large pellets made with 100% Wyoming bentonite increased the dry density from 1.2 Mg/m³ to over 1.4 Mg/m³ when 20% fines, by weight, were added. A further increase in dry density was achieved when 30% fines were added (1.55 Mg/m³). These densities correspond to thermal conductivities above 0.65 W/(m·K). The best results were obtained with the small pellets made with 100% Wyoming bentonite with 30% fines. This combination increased the dry density to over 1.6 Mg/m³ and gave a thermal conductivity of 0.69 W/(m·K). When fines were added to pellets composed with 10% silica sand, the beneficial effects of the silica with respect to thermal conductivity was masked, and thermal conductivity was reduced (Figure 39d). The addition of illite to the pellets tended to lower thermal conductivity (Figure 39e). The addition of fines to the large pellets made with 75% Wyoming bentonite and 25 % illite simply increased the thermal conductivity into the range representative of pellets made with 100% bentonite.

Table 16: Thermal Conductivity of Pellet Fills

Pellet Composition	Densification	Thermal Conductivity (W/(m·K)) (for various pellet sizes)		
		Small	Medium	Large
Wyoming	Poured:	0.34-0.45	0.41	0.48
	Vibrated:	0.52-0.61	0.59	0.56
	Vibrated with 20% fines:	-	-	0.65
	Vibrated with 30% fines:	0.62-0.69	-	0.67
Asha	Poured:	0.43	-	0.43
	Vibrated:	0.49	-	0.54
Milos AC200	Poured:	0.44	-	0.45
	Vibrated:	0.54	-	0.61
Milos B	Poured:	0.47	-	0.43
	Vibrated:	0.58	-	0.63
Cebogel pellets	Poured:	0.46	-	-
	Vibrated:	0.53	-	-
Buffer Test Pellets	Poured:	0.52	-	-
	Vibrated:	0.56	-	-
10% Silica Sand	Poured:	-	0.45	-
	Vibrated:	-	0.61	-
	Vibrated with 30% fines:	-	0.52	-
25% Silica Sand	Poured:	0.44	0.45	0.56
	Vibrated:	0.52	0.59	0.56
50% Silica Sand	Poured:	0.44	-	-
	Vibrated:	0.52	-	-
10% Illite	Poured:	-	0.49	0.39
	Vibrated:	-	0.56	0.49
25% Illite	Poured:	0.42	0.41	0.38
	Vibrated:	0.48	0.53	0.49
	Vibrated with 30% fines:	-	-	0.54
50% Illite	Poured:	0.46	0.51	-
	Vibrated:	0.51	0.52	-

Note: "fines" consist of 80 mesh Wyoming bentonite granules (similar to MX-80)

5.7.6 Summary

The overall message provided by this data set is that up to a point, increased as-placed density has a greater effect on increasing thermal conductivity than the addition of silica sand or illite to the bentonite in the individual pellets. For pellets composed of 100% Wyoming bentonite, the addition of fines to fill the voids between pellets increased the dry density and increased thermal conductivity to just below the desired range of 0.7 to 0.9 W/(m·K).

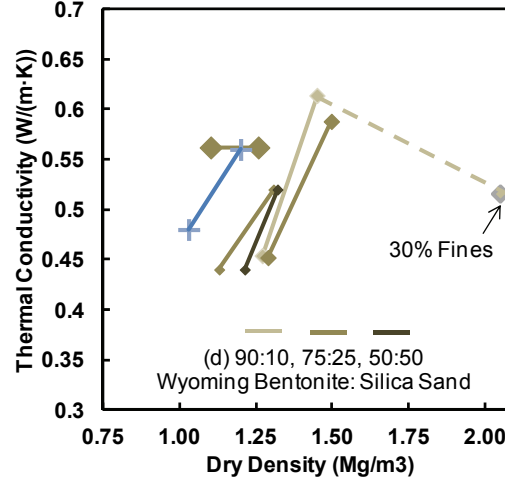
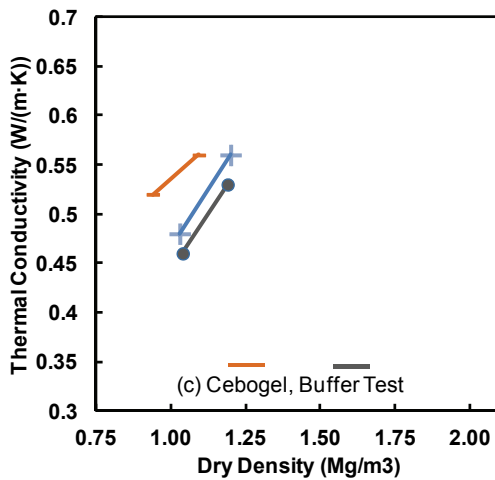
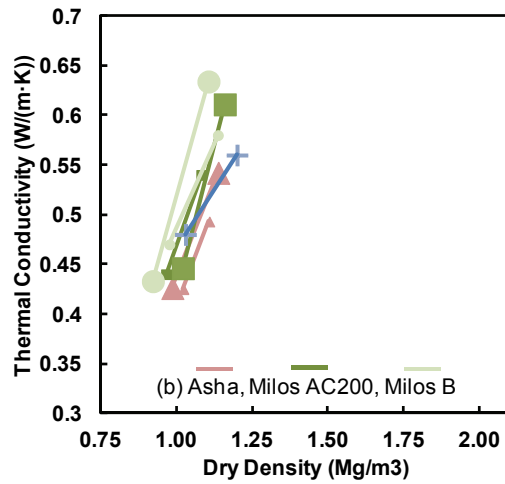
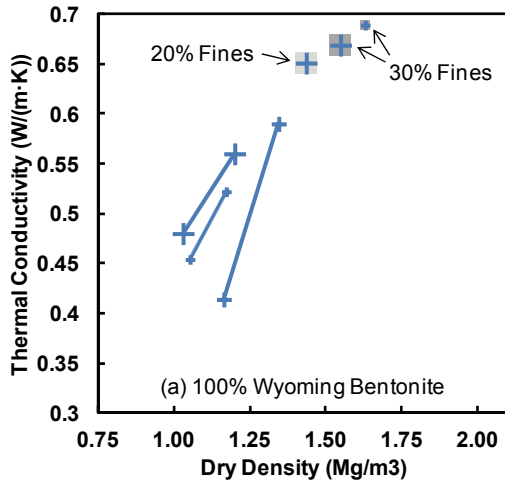

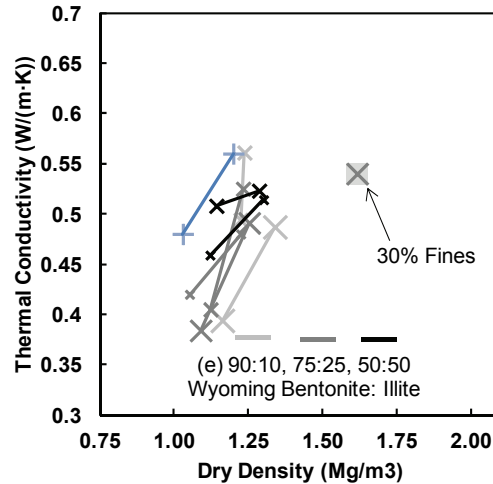

Figure 39: Comparison of Thermal Conductivity Values for Different Sizes and Compositions of Pellets

6. DISCUSSION AND CONCLUSIONS

The objective of this work was to evaluate the potential of developing bentonite based pellets that better meet the requirements of NWMO, SKB and Posiva for application as gap fill as well as tunnel backfill. A total of 56 batches of pellets were made for the study, representing a range of pellet sizes, shapes and the effects of various volumetrically inert fillers on the properties of bentonite-based materials.

The pellets were assessed primarily to evaluate potential to improving their density, strength, durability and heat transfer capability. Several different swelling clay materials of interest to NWMO, SKB and Posiva were examined as well as mixtures of bentonite with illitic clay or fine silica sand. Filler contents of 10, 25, and 50% by weight were tested. Based on preliminary characterisation results six pellet types were selected for additional advanced testing by Posiva and VTT in Finland and SKB and Clay Technology in Sweden. These tests are ongoing and are not reported on in this report.

Source material (clay) granularity was determined to be an important factor, influencing the roller pressure needed to produce good quality pellets. It was found that coarser feed material increased roller pressure and risked stalling the machine. As a result, unprocessed “clay” materials such as Milos B bentonite, required pre-treatment of the materials to screen out the larger aggregates and impurities (e.g. course sand-sized particles). This demonstrated the need for a consistent feed material during production of pellets and highlighted a key factor in determining the quality of the product produced.

The as-received moisture (5-13% gravimetric) of most of the raw stock materials examined was generally sufficient to produce good quality pellets. When moisture was added to the feed material it tended to stick to the rollers, producing poorly shaped pellets. In cases where the as-received moisture content was too high, pre-treatment (partial drying) of the stock material was required. Asha bentonite is an example of material that required some drying prior to pellet manufacturing.

In general the dry density of the pellets produced was higher at lower water content ranges and the EMDD of the individual pellets was not substantially affected by the presence of modest quantities of filler (typ. <25%). Hence the presence of filler materials should not adversely affect the swelling pressure developed or the hydraulic conductivity of the pellets. This has relevance to both the economics of pellet manufacturing as well as the performance of this barrier component.

The pellets produced all had individual pellet dry densities in the order of 2.0 Mg/m^3 . When loosely poured, the dry bulk density of the mass of pellets was generally in the order of 1.0 to 1.2 Mg/m^3 . This could be improved with vibratory compaction but the dry bulk density of most of the pellets after vibration was still less than 1.4 Mg/m^3 . The exceptions to these density limits were some of the pellets made with substantial silica sand and illite additives but the as-placed density of these materials were not substantially higher (e.g. $<1.6 \text{ Mg/m}^3$ dry density).

The addition of Wyoming bentonite fines (i.e. 80 mesh granules), vibrated into the pore space between the pellets was undertaken to evaluate their effect on overall density and thermal characteristics of the gap fill. The fines typically resulted in improved as-placed dry density ($>1.5 \text{ Mg/m}^3$). This would result in improved hydraulic and swelling behaviour of the fill material but would also limit the ability of the pellet fill to transfer inflowing water into its internal volume during the initial wetting stages. This could potentially result in localised variability of swelling pressure and earlier development of preferential flow paths.

The addition of additives such as silica sand and illite had only a small effect on the thermal conductivity of a mass of pellets relative to pellets made with 100% bentonite. Increasing the overall density through vibratory compaction resulted in an increase of the thermal conductivity that was greater than the effect of additives. This added variable of inter-pellet porosity dominates relative to the addition of admixtures that showed promise with pucks of bentonite-additive mixtures. The highest values of thermal conductivity following vibratory compaction were achieved with the large pellets made with Milos AC200 bentonite, the large pellets made with Milos B bentonite, and the medium sized pellets made with a mixture of 90% bentonite and 10% silica sand. The size of these pellets makes them unsuitable for gap fill use in the IFB geometry, but are of interest in the HTP geometry or as tunnel backfill. A thermal conductivity value of about $0.6 \text{ W/(m}\cdot\text{K)}$ appears to represent the maximum achieved without the addition of fines to fill the void space between the pellets. The maximum thermal conductivity values measured on pellets densified by vibratory compaction were close to $0.6 \text{ W/(m}\cdot\text{K)}$ which is below a more desirable range of 0.7 to $0.9 \text{ W/(m}\cdot\text{K)}$.

The vibration of Wyoming bentonite fines (80 mesh granules) generally provided a slight improvement to the thermal conductivity of all the pellet fill materials. The maximum thermal conductivity achieved through the addition of fines was $0.69 \text{ W/(m}\cdot\text{K)}$ using the small 100% Wyoming bentonite pellets with 30% fines vibrated into the pore space between the pellets. The greatest improvement offered by the addition of fines was a significant increase in bulk density of the as-placed material (e.g. over 1.5 Mg/m^3).

In summary; the implications of this study on the use of pellet materials in a repository are as follows:

- The pellet manufacturing process is sensitive to the water content of the source materials. In the tests completed in this study it was found that low (<15% and often <10%) gravimetric water content in the feed material was necessary in order to produce pellets of adequate durability.
- 100% bentonite (from various sources) can be used to produce dense pellets of reasonable durability for placement in a repository.
- The thermal conductivity of the pellet materials evaluated in this study is ~0.5 to ~0.6 W/(m·K) following vibratory compaction. This may not be sufficient for the HTP geometry but does represent a substantial improvement in the heat transfer characteristics relative to the air-gap otherwise present in the IFB geometry.
- The presence of silica sand and illite did not significantly increase the thermal conductivity of the as-placed material relative to the clay-only pellets. The thermal properties are dominated by the large, air-filled voids between the pellets. Over the longer term, once the clay has hydrated and swelled to fill these gaps there will likely be only a limited effect of additives on heat transfer since the water component dominates the system.
- The addition of fines (80 mesh Wyoming bentonite granules) to the pore space between pellets (20% to 30% fines by weight) resulted in an increase in thermal conductivity, but not greater than 0.7 W/(m·K). This is of interest in the HTP geometry where the fill is relied on to transfer the heat from the UFC to the surrounding rock mass in a generally dry environment.
- With the addition of fines (80 mesh Wyoming bentonite granules: 20% to 30% fines by weight), the bulk density of the as-placed material can be substantially increased. This may be of relevance to applications where pellet fill is placed in the HTP geometry. This will improve the initial and longer-term thermal conduction characteristics of the materials surrounding the UFC. In the IFB geometry, fines could also result in a higher buffer density being maintained within the borehole.
- The addition of a fine silica sand material resulted in a higher crush strength for the pellets. This may be of value where the pellets are considered for use in locations where they need to maintain a discernible crush strength (e.g. flooring materials where block and pellet backfilling occurs). This strength, if also associated with a reasonable erosion resistance (mechanical and hydraulic) could also be of value in pellet materials used in tunnel backfill applications. There was some correlation between crush strength and abrasion resistance.
- Illitic clay addition did not result in any substantive improvement in the mechanical or thermal characteristics of the pellets. The presence of this component may influence the ability of water to erode the pellet fill and adjacent bentonite materials but this was not evaluated as part of this project.

Ongoing work in Finland and Sweden will provide more insight into the hydraulic and mechanical performance of pellets as part of the fill materials used in the IFB and HTP geometries. While this study focussed on use of roller-compacted pellet materials, ongoing work in Finland and Sweden will include pellets manufactured using extrusion technology and will provide a valuable basis for comparison.

ACKNOWLEDGEMENTS

The work described in this document is the result of a co-operative research project funded by the Nuclear Waste Management Organisation of Canada, the Swedish nuclear fuel and waste management company (SKB) and Posiva Oy of Finland. The authors would like to acknowledge the assistance of B. Evenden and F. Johnston of AECL in the conduct of the laboratory testing done at AECL's Geotechnical Laboratory.

REFERENCES

- Ahonen, L., P. Korkeakoski, M. Tiljander, H. Kivikoski and R. Laaksonen. 2008. Quality assurance of the bentonite material, Posiva Oy, Working Report-2008-33, Olkiluoto.
- Carlson, L. 2004. Bentonite mineralogy. Part 1: Methods of Investigation – A Literature Review. Part 2: Mineralogical Research of Selected Bentonites. Posiva Oy, Working Report-2004-02, Olkiluoto.
- Chandler, N., A. Cournot, D. Dixon, C. Fairhurst, F. Hansen, M. Gray, K. Hara, Y. Ishijima, E. Kozak, J. Martino, K. Masumoto, G. McCrank, Y. Sugita, P. Thompson, J. Tillerson and B. Vignal. 2002. The five year report of the Tunnel Sealing Experiment: an international project of AECL, JNC. Atomic Energy of Canada Limited Report AECL-12727.
- De Bock, C., J-M. Bosgiraud, H. Weber, T. Rothfuchs, J. Verstricht, B. Breen and M. Johnson. 2008. Achievements of the ESDRED project in buffer construction technology, (K. Wolf, W.K Seidler and J.M. Bosgiraud, Editors), Euradwaste '08 conference ESDRED – An Integrated European Project Focused on Technology Development.
- Dixon, D.A. 1995. Towards and understanding of water structure and water movement through dense clays, Ph.D. Thesis, University of Manitoba, Dept Civil Engineering, Winnipeg.
- Dixon D., S. Stroes-Gascoyne, B. Kjartanson and P. Baumgartner. 2005. Development of Sealing Materials for Application as Engineered Barriers in a Deep Geologic Repository for Used Fuel Disposal: Filling the Gaps, Canadian Nuclear Society Waste Management, Decommissioning and Environmental Restoration for Canada's Nuclear Activities: Current and Future Needs Ottawa, Ontario, Canada, May 8-11, 2005.
- Dixon, D.A. and P. Keto. 2008. Backfilling techniques and materials in underground excavations : Application to Posiva's spent fuel repository, Posiva Oy, Working Report-2008 – 56, Olkiluoto.
- Dixon, D., S. Anttila, M. Viitanen and P. Keto. 2008a. Tests to determine water uptake behaviour of tunnel backfill (Baclo Tests at Äspö). Swedish Nuclear Fuel and Waste Management Company, SKB- R-08-134, Stockholm.
- Dixon, D., C. Lundin, E. Örtendahl, M. Hedin and G. Ramqvist. 2008b. Deep repository – engineered barrier system: Half-scale tests to examine water uptake by bentonite pellets in a block-pellet backfill system. Swedish Nuclear Fuel and Waste Management Company, SKB- R-08-132, Stockholm.
- Dixon, D.A., J.B. Martino, B. Holowick and D. Priyanto. 2011. Enhanced Sealing Project: Monitoring the THM response of a full-scale shaft seal. Canadian Nuclear Society Conference, Waste Management, Decommissioning and Environmental Restoration for Canada's Nuclear Activities September 11-14, 2011, Toronto.

- Dixon, D., E. Jonsson, J. Hansen, M. Hedin and G. Ramqvist. 2011a. Effect of localized water uptake on backfill hydration and water movement within a backfilled tunnel: half-scale tests at Äspö bentonite laboratory. Swedish Nuclear Fuel and Waste Management Company, SKB- R-11-27, Stockholm.
- Dixon, D., T. Sandén, E. Jonsson and J. Hansen. 2012. Backfilling of deposition tunnels: Use of bentonite pellets. Swedish Nuclear Fuel and Waste Management Co, SKB, Stockholm. R-Series report, SKB P-11-44, Stockholm.
- EN 1097-1 + A1: Tests for mechanical and physical properties of aggregates. Part 1: Determination of the resistance to wear (micro-Deval). 2011.
- Hansen, J., L. Korkiala-Tanttu, E. Keski-Kuha and P. Keto. 2009. Deposition tunnel backfill design for a KBS-3V repository. Posiva Oy, Working Report-2009-129, Olkiluoto.
- Johannesson, L-E and U. Nilsson. 2006. Deep repository – Engineered barrier systems; geotechnical behaviour of candidate backfill materials, laboratory tests and calculations for determining performance of the backfill. Swedish Nuclear Fuel and Waste Management Co., SKB, R-06-73, Stockholm.
- Johannesson, L.E. 2008. Geotechnical investigations made on unsaturated backfill materials. Swedish Nuclear Fuel and Waste Management Co., SKB, SKB-R-08-131, Stockholm.
- Johannesson, L-E., T. Sandén, A. Dueck and L. Ohlsson. 2010. Deep repository- Engineered barrier system: Characterisation of a backfill candidate material, IBECO-RWC-BF, BACLO PROJECT-PHASE 3 - Laboratory tests. Swedish Nuclear Fuel and Waste Management Company, SKB-10-44, Stockholm.
- Juvankoski, 2010. Description of basic design for buffer. Posiva Oy, Working Report WR-2009-131, Olkiluoto.
- Keto P., D. Dixon, E. Jonsson, D. Gunnarsson, L. Börgesson and J. Hansen. 2009. Assessment of backfill design for KBS-3V repository. Swedish Nuclear Fuel and Waste Management Company, SKB-R-09-52, Stockholm.
- Kiviranta, L. and S.Kumpulainen. 2011. Quality control and characterisation of bentonite materials. Posiva Oy, Working Report-2011-84, Olkiluoto.
- Kjartanson, B., D. Dixon and C. Kohle. 2005. Placement of bentonite pellets to fill repository sealing system voids and gaps. Ontario Power Generation, Nuclear Waste Management Divison, Technical Report, 06819-REP-01200-10136, Toronto.
- Man, A. and J.B. Martino. 2009. Thermal, hydraulic and mechanical properties of sealing materials. NWMO, Technical Report, NWMO TR-2009-20, Toronto.
- Man, A., J. Martino, C-S. Kim and D. Priyanto. 2011. Characterizing and improving the thermal conductivity of engineered clay barriers for sealing a deep geological repository. Canadian Nuclear Society Conference, Waste Management,

Decommissioning and Environmental Restoration for Canada's Nuclear Activities, 2011 Sept 11-14, Toronto.

Marjavaara, P. and H. Kivikoski. 2011. Filling the gap between buffer and rock in the deposition hole. Posiva Oy, Working Report-2011-33, Olkiluoto.

Martino, J. and D. Dixon. 2006. Placement and formulation studies on potential light backfill and gap fill materials for use in repository sealing. Ontario Power Generation, Nuclear Waste Management Division, Supporting Technical Report, 06819-REP-01300-10011-R00, Toronto.

Martino, J., D. Dixon, S. Stroes-Gascoyne, R. Guo, E. Kozak, M. Gascoyne, T. Fujita, B. Vignal, Y. Sugita, K. Masumoto, T. Saskura, X. Bourbon, A. Gingras-Genois and D. Collins. 2008. The Tunnel Sealing Experiment 10 year summary report. Atomic Energy of Canada Limited, URL-121550-REPT-001, Chalk River.

Martino, J.B., D.A. Dixon, B.E. Holowick and C-S. Kim. 2011. Enhanced Sealing Project (ESP): Seal Construction and Instrumentation Report. Nuclear Waste Management Organization, NWMO, APM-REP-01601-0003, Toronto.

Olsson, S. and O. Karnland. 2009. Characteristics of bentonites from Kutch, India and Milos, Greece – some candidate tunnel backfill materials. Swedish Nuclear Fuel and Waste Management Company, SKB-R-09-53, Stockholm.

Oscarson, D.W. and D.A. Dixon. 1989. Elemental, mineralogical, and pore-solution compositions of selected Canadian clays. Atomic Energy of Canada Limited, Report AECL-9891, Chalk River.

Quigley, R.M. 1984. Quantitative mineralogy and preliminary pore-water chemistry of candidate buffer and backfill materials for a nuclear fuel waste disposal vault. Atomic Energy of Canada Limited, Technical Report, AECL 7827, Chalk River.

Radhakrishna, H.S. and H.T. Chan. 1982. Laboratory study of physical properties of clay buffers for a nuclear fuel waste vault. Proc. 1st Intl. Conference on Radioactive Waste Management, September 1982, Winnipeg.

Radhakrishna, H.S. and H.T., Chan. 1985. Strength and hydraulic conductivity of clay-based buffers for a deep underground nuclear fuel waste disposal vault. Atomic Energy of Canada Limited, Technical Report, TR-327, Chalk River.

Riikonen, E. 2009. Flow-through and wetting tests of pre-compacted backfill blocks in a quarter-scale test tunnel. MSc. Thesis, Helsinki University of Technology, Espoo.

Sandén, T., L. Börgesson, A. Dueck, R. Goudarzi and M. Lönnqvist. 2008. Deep repository-engineered barrier system; erosion and sealing processes in tunnel backfill materials investigated in laboratory. Swedish Nuclear Fuel and Waste Management Co., SKB R-08-135, Stockholm.

SKB. 2010. Buffer, backfill and closure process report for the safety assessment SR-Site, Swedish Nuclear Fuel and Waste Management Co., SKB, TR-10-47, Stockholm.

- TKS. 2009. Nuclear Waste Management at Olkiluoto and Loviisa Power Plants: Review of current status and future plans for 2010–2012. Posiva Oy, Olkiluoto.
- Volckaert, G. 2000. A large scale in situ demonstration test for repository sealing in an argillaceous host rock - Reseal Project Phase 1. EUR report 19612.
- Vuorinen, J. 1999. Papers of Road Office in Finland 30/1999. The comparability of Nordic abrasion test and Micro-Deval test. Finnish Road Administration, 2000, 28 pp. *in Finnish*.

**APPENDIX A: MATERIAL DESCRIPTIONS AND MANUFACTURERS'
DATA SHEETS**

PRODUCT
DATA



Cebo Holland

CEBOGEL QSE

Use

The large swelling capacity makes CEBOGEL QSE suitable for:
The complete repair of drilled-through or damaged clay layers
Securing spring-loaded charges in the ground for seismological study
Making dams, dykes and water barriers non-water-permeable
Rapidly sealing damaged wells, etc..

Careful and even dosing are required for an optimal result.
Bridge formation can occur in the event of dosing too rapidly.

Description

Cylindrical bentonite rods (granules) made from 100 % activated sodium bentonite. A characteristic of CEBOGEL QSE is its considerable water absorption capacity, as a result of which it swells up considerably when in contact with water. The QSE quality is KIWA certified in the field of toxicological aspects.

Advantages

- The assurance of a strong, virtually watertight layer which can only be achieved using a pure sodium bentonite
- Has extra swelling capacity for sealing irregularities in the borehole wall or difficult to reach cavities
- Certified according to KIWA-ATA, therefore absolutely safe for use in drinking water areas
- Easy to apply
- Absolutely environmentally-friendly

Specification

Complies with the requirements set in BRL-K20236/01 for borehole clay for sealing boreholes in bottom layers with poor water permeability
Supplied with KIWA certificate for Toxicological Aspects (ATA), which guarantees an environmentally-friendly product

Parameter	Method	Requirement	Typical Value
Water absorption capacity after 24 hours	ASTM E946-92	≥ 600 % (BRL-265/01)	800 %

Cebo Holland BV
Westerdunweg 1
NL-1976 BV IDMUJIDEN
P.O. Box 70
NL-1970 AB IDMUJIDEN

Tel.: +31 255546262
Fax: +31 255546202
e-mail: sales@ceboholland.com
www.ceboholland.com

In so far as we can ascertain the above-stated information is correct. However, we are unable to provide any guarantees with regard to the results that you will achieve with this. This specification is provided on the condition that you determine yourself to what degree it is suitable for your purposes.

CEBOGEL QSE (pg 2/2)

Typical values

Montmorillonite level X-ray diffraction	80 %
Moisture content DIN 18121	16 %

Chemical and physical properties

Composition	High-quality activated sodium bentonite
Colour	Grey green
Form	Cylindrical rods
Dimensions	Diameter 6.5 mm Length 5 – 20 mm
Density	2100 kg/m ³
Bulk density	1100 kg/m ₃

Packaging

- 1000 kg packed in 25 kg polyethylene bags on a pallet with shrink film
- 1000 kg big bags

Revision date : 10-07-2003

Document no : CQ03IP

In so far as we can ascertain the above-stated information is correct. However, we are unable to provide any guarantees with regard to the results that you will achieve with this. This specification is provided on the condition that you determine yourself to what degree it is suitable for your purposes.



**Fine Granular
Industrial Sodium Bentonite**

MX 80

General Description	Fine granular Sodium Bentonite with an average particle size ranging between 16 and 200 mesh.																				
Functional Use	Multi-purpose product noted for rapid dispersion in water. Employed in a wide variety of industrial applications.																				
Purity	Hydrous aluminium silicate comprised principally of the clay mineral Montmorillonite. Montmorillonite content 90% minimum. Contains small portions of feldspar, biotite, selenite, etc.																				
Chemical Composition	<p>Typical Analysis (moisture free)</p> <table><tr><td>SiO₂</td><td>63.02%</td><td>MgO</td><td>2.67%</td></tr><tr><td>Al₂O₃</td><td>21.08%</td><td>Na₂O</td><td>2.57%</td></tr><tr><td>Fe₂O₃</td><td>3.25%</td><td>CaO</td><td>0.65%</td></tr><tr><td>FeO</td><td>0.35%</td><td>H₂O</td><td>5.64%</td></tr><tr><td>Trace</td><td>0.72%</td><td></td><td></td></tr></table>	SiO ₂	63.02%	MgO	2.67%	Al ₂ O ₃	21.08%	Na ₂ O	2.57%	Fe ₂ O ₃	3.25%	CaO	0.65%	FeO	0.35%	H ₂ O	5.64%	Trace	0.72%		
SiO ₂	63.02%	MgO	2.67%																		
Al ₂ O ₃	21.08%	Na ₂ O	2.57%																		
Fe ₂ O ₃	3.25%	CaO	0.65%																		
FeO	0.35%	H ₂ O	5.64%																		
Trace	0.72%																				
Chemical Formula	A tri-layer expanding mineral structure of approximately: (Al, Fe _{1.67} , Mg _{0.33}) Si ₄ O ₁₀ (OH) ₂ Na+Ca ₂ + _{0.33}																				
Moisture Content	Maximum 12% as shipped.																				
Dry Particle Size	Maximum 10% retained on 18 mesh (850 microns) Maximum 15% passing 200 mesh (75 microns)																				
pH	5% solids dispersion 8.5 to 10.5																				
Viscosity	1 part bentonite to 15 parts deionised water (6.25% solids) Dispersed on high-speed mixer. Fann viscometer , 8cps. Minimum																				
Packaging	Multi – wall paper bags, (25 kg), big-bags or bulk																				

© 2006 AMCOL Specialty Minerals is a trading division of
AMCOL Minerals Europe Ltd.
Registered in England No. 2347184
Registered Office: Weaver Valley Rd, Winsford, Cheshire, CW7 3BU England Tel: +44 (0) 1606 868200 | Fax: +44 (0) 1606 868268
a wholly-owned subsidiary of AMCOL International Corporation

The information and data contained herein are believed to be accurate and reliable. AMCOL Specialty Minerals makes no warranty of any kind and accepts no responsibility for the results obtained through application of this information.

Data from website: masco.net/pdf/catalogs/liquidand powder/datasheets/TD_MX_80.pdf



PRODUKTDATABLAD

Division: Minerals
 Varugrupp: 2830
 Utfärdad: 2005-02-14
 Version: 1.1
 Godkänt av / Datum: 18/2-05

BENTONITE VOLCLAY MX80

General description

Fine granular sodium bentonite with an average particle size ranging between 16 and 200 mesh.

Functional use

Multipurpose product noted for rapid dispersion in water. Employed in a wide variety of industrial applications.

Chemical formula

A tri-layer expanding mineral structure of approximately:

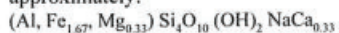

Purity

Hydrous aluminum silicate comprised principally of the clay mineral Montmorillonite. Montmorillonite content 90% minimum. Contains small portions of feldspar, biotite, selenite, etc.

Chemical composition

Typical analysis (moisture free).

SiO ₂	53,3 %
Al ₂ O ₃	17,0 %
Fe ₂ O ₃	5,5 %
TiO ₂	0,7 %
MgO	3,8 %
Na ₂ O	2,8 %
CaO	5,1 %
K ₂ O	0,9 %

Physical properties

pH	5 % solids dispersion 8.5 to 10.5
Moisture content	Max 12 % as shipped
Dry particle size	Max 10 % retained on 18 mesh (850 microns) Max 15 % passing 200 mesh (75 microns)
Viscosity	1 part Bentonite to 15 parts deionised water (6.25 % solids) dispersed on high-speed mixer. FANN viscometer, 8 cps min.

Packaging

25 kgs multi-wall paper bags or bulk.

Wyoming Bentonite Used in Pellet Manufacture: NSB-BC200-2008



BARA-KADE®

200 Bentonite

Description BARA-KADE® 200 is a high yield Wyoming sodium bentonite that is used in trenching, bored piling, and slurry wall installation. It is also used in soil sealing and other hydraulic barrier applications.

- Applications/Functions**
- Slurry trenching
 - Soil sealing
 - Tunnel boring
 - Other hydraulic barrier applications
 - Low solids coring fluid for mineral exploration

- Advantages**
- Treated high purity sodium based bentonite.
 - Easy to mix and yield a homogeneous, high viscosity mineral slurry.
 - Provides a stable slurry without separation for prolonged periods.
 - Compatible with cement and other construction additives.

Screen Analysis

	<u>Typical</u>	<u>Specification</u>
• Dry screen, percent minus 200 mesh	•	• 67.5 min
• Wet screen, percent plus 200 mesh	•	• 4 max

Properties

	<u>Typical</u>	<u>Specification</u>
• Moisture, percent	•	• 12 Max
• Aged Fann® 600 RPM(10.0gr/350ml)	•	• 24 Min
• Filtrate Loss	•	• 27 Max
• Specific Gravity	• 2.7	•
• Bulk Density (lbs/ft ³ compacted)	• 73	•
• Bulk Density (lbs/ft ³ uncompacted)	• 53	•

Availability BARA-KADE® 200 can be purchased through any Bentonite Performance Minerals LLC assigned Reseller. To locate the BPM Reseller nearest you, contact the Customer Service Department in Houston or your area BPM Regional Sales Manager.

Bentonite Performance Minerals LLC
A Halliburton Company
3000 N. Sam Houston Pkwy E.
Houston, TX 77032
www.bentonite.com

Customer Service (281) 871-7900 **Fax** (281) 871-7940

IBECO RWC-2008: Milos HQ : AC200

S&B Industrial Minerals GmbH



IBECO RWC

Beschreibung	Product description	Description
IBECO RWC ist ein natürlicher Calziumbentonit mit hohem Montmorillonitgehalt	IBECO RWC is a natural calcium bentonite with a high montmorillonite content	IBECORWC est une bentonite calcique naturelle à haute teneur en montmorillonite

Anwendung	Application	Application
Als „buffer“ Bentonit zur Einbettung von Containern für radioactive Abfälle in unterirdischen Endlagern	As buffer bentonite for the imbedding of containers for radioactive wastes in underground repositories	Comme « buffer » bentonite à l'encastrement des containers pour des déchets radioactifs dans dépôts souterrains

	Technische Durchschnittswerte	Typical values	Caractéristiques générales		
w	Wassergehalt ISO 787/2	Water content	Humidité	10 ± 2	%
ρ _s	Dichte DIN 51057	Specific density	Poids spécifique	2,65	g/ml
	Schüttdichte DIN 53466	Bulk density	Densité apparente tassée	1020 ± 50	g/ml
	Kornverteilung	Distribution of grains	Distribution aus grains	0 - 5	mm
	Siebrückstand auf Sieb 0,063 mm DIN 53734	Dry screen residue on sieve 0,063 mm	Refus au tamis (voie sèche) 0,063 mm	> 80	%
	Montmorillonit-Gehalt (Methylenblau-Methode)	Montmorillonite content (Methylen-blue-Method)	Teneur en Montmorillonite (Méthode au bleu de Méthylène)	≥ 75	%
CEC	Kationenaustauschkapazität	Cation exchange capacity	Capacité d'échange de cations	> 80	mval/100g
w _A	Wasseraufnahmevermögen Enslin-Neff, DIN 18132	Water absorption capacity	Capacité d'absorption d'eau	160 ± 30	%
	Quellvolumen	Swelling index	Gonflement	≥ 5	ml/2g

Lieferform	Delivery	Livraison
Lose per Silo-Lkw In Säcken, auf Paletten, geschrumpft In Big Bags	Bulk per road tanker In bags on pallets, shrink wrapped In Big Bags	Vrac en camion-silo En sacs sur palette filmée En Big Bags

Da wir auf die Verwendung unseres Produktes keinen Einfluß nehmen können, beschränkt sich unsere Haftung auf diese Produktinformation	The values listed are indicative and are not to be construed as rigid specifications	Les renseignements contenus dans cette fiche technique sont fournis à titre indicatif et ne peuvent engager notre responsabilité.
---	--	---

S&B Industrial Minerals GmbH
- Specialty bentonites & additives-
Ruhrtorfer Straße 72 • D – 68219 Mannheim • Tel.+49 6 21 / 8 04 27-0 • Fax +49 6 21 / 8 04 27-50

IBECO RWC-BF : Milos B : IBECO DEPONIT-BF

S&B Industrial Minerals GmbH



IBECO RWC-BF

Beschreibung	Description	Description
Natürlicher Calziumbentonit mit mittlerem Montmorillonitgehalt	Calcium bentonite natural with a medium montmorillonite content	Bentonite calcique naturelle à moyen teneur en montmorillonite

Anwendung	Application	Application
Als Dicht- und Versatzmaterial für Untertage-Deponien	As sealing and backfilling material for underground repositories	Comme cachetage et matériel de remblai pour les dépôts souterrains

	Technische Durchschnittswerte	Technical values (average)	Valeur techniques (moyenne)		
w	Wassergehalt ISO 787/2	Water content	Teneur d'eau	16 ± 1,5	%
ρ _s	Dichte DIN 51057	Specific density	Poids spécifique	2,65	g/cm ³
	Schüttdichte DIN 53466	Bulk density	Densité apparente tassée	1020 ± 50	g/l
	Körnung	Grain size	Granulation	0 – 5	mm
	Siebrückstand auf Sieb 0,063 mm DIN 53734	Dry screen residue on sieve 0,063 mm	Refus au tamis (voie sèche) 0,063 mm	> 80	%
	Methylenblau-Adsorption VDG P69	Methylen-blue-adsorption	Adsorption du bleu de méthylène	300 ± 30	mg/g
CEC	Kationenaustauschkapazität	Cation exchange capacity	Capacité d'échange de cations	60 ± 10	mval/100g
w _A	Wasseraufnahmevermögen Enslin-Neff, DIN 18132	Water absorption capacity	Capacité d'absorption d'eau	150 ± 30	%
	Quellvolumen	Swelling index	Gonflement	≥ 7	ml/2g
w _L	Fließgrenze DIN 18122	Liquid limit	Limite de liquidité	115	%
w _p	Ausrollgrenze DIN 18122	Plastic limit	Limite de plasticité	33	%
I _p	Plastizitätszahl (errechnet)	Plasticity index (calculated)	Indice de plasticité (calculée)	82	%

Lieferform	Delivery	Livraison
<ul style="list-style-type: none"> • Lose per Silo-Lkw • In Säcken, auf Paletten, geschrumpft • In Big Bags 	<ul style="list-style-type: none"> • Bulk per road tanker • In bags on pallets, shrink wrapped • In big bags 	<ul style="list-style-type: none"> • Vrac en camion-silo • En sacs sur palette filmée • En big bags

Da wir auf die Verwendung unseres Produktes keinen Einfluss nehmen können, beschränkt sich unsere Haftung auf diese Produktinformation.	The values listed are indicative and are not to be construed as rigid specifications.	Les renseignements contenus dans cette fiche technique sont fournis à titre indicatif et ne peuvent engager notre responsabilité.
---	---	---

S&B Industrial Minerals GmbH
 - Geschäftsbereich IBECO -
 Ruhrorter Straße 72 • D – 68219 Mannheim • Tel.+49 6 21 / 8 04 27-0 • Fax +49 6 21 / 8 04 27-50

DKOC 08.12

IBECO DEPONIT CA : IBECO RWC-BF : Milos B

S&B Industrial Minerals GmbH



Calziumbentonit IBECO DEPONIT CA

Beschreibung	Description	Description
Natürlicher Calziumbentonit mit hohem Montmorillonitgehalt	Calcium bentonite natural with a high montmorillonite content	Bentonite calcique naturelle à haute teneur en montmorillonite

Anwendung	Application	Application
Für bentonitvergütete Dichtungsschichten im Deponiebau sowie Sorptionsschichten.	For bentonite enriched liners in landfills and for sorption layers.	Étanchéité de décharges et couches d'adsorption.

	Technische Durchschnittswerte	Technical values (average)	Valeur techniques (moyenne)		
w	Wassergehalt ISO 787/2	Water content	Teneur d'eau	10 ± 2	%
ρ _s	Dichte DIN 51057	Specific density	Poids spécifique	2,65	g/cm ³
	Schüttdichte DIN 53466	Bulk density	Densité apparente tassée	800 ± 50	g/l
	Mahlfeinheit d _w auf Sieb 0,063 mm DIN 53734	Dry screen residue on sieve 0,063 mm	Refus au tamis (voie sèche) 0,063 mm	20 ± 5	%
	Methylenblau-Adsorption VDG P69	Methylen-blue-adsorption	Adsorption du bleu de méthylène	300 ± 30	mg/g
CEC	Kationenaustauschkapazität	Cation exchange capacity	Capacité d'échange de cations	60 ± 10	mval/100g
w _A	Wasseraufnahmevermögen Enslin-Neff, DIN 18132	Water absorption capacity	Capacité d'absorption d'eau	≥ 160	%
	Quellvolumen	Swelling index	Gonflement	≥ 7	ml/2g
w _l	Fließgrenze DIN 18122	Liquid limit	Limite de liquidité	115	%
w _p	Ausrollgrenze DIN 18122	Plastic limit	Limite de plasticité	33	%
I _p	Plastizitätszahl (errechnet)	Plasticity index (calculated)	Indice de plasticité (calculée)	82	%

Lieferform	Delivery	Livraison
<ul style="list-style-type: none"> • Lose per Silo-Lkw • In Säcken, auf Paletten, geschrumpft • In Big Bags 	<ul style="list-style-type: none"> • Bulk per road tanker • In bags on pallets, shrink wrapped • In big bags 	<ul style="list-style-type: none"> • Vrac en camion-silo • En sacs sur palette filmée • En big bags

Da wir auf die Verwendung unseres Produktes keinen Einfluss nehmen können, beschränkt sich unsere Haftung auf diese Produktinformation.	The values listed are indicative and are not to be construed as rigid specifications.	Les renseignements contenus dans cette fiche technique sont fournis à titre indicatif et ne peuvent engager notre responsabilité.
---	---	---

S&B Industrial Minerals GmbH
 Ruhrorter Straße 72 • D – 68219 Mannheim
 Tel.+49 6 21 / 8 04 27-0 • Fax +49 6 21 / 8 04 27-50

AMAN/HSPE 0310

APPENDIX B: RESULTS OF PELLET TESTING: DATA TABLES

CONTENTS

	<u>Page</u>
Table B-1: Results of Free Swell Tests.....	91
Table B-2: Density Achieved in Small Volume Pouring Tests for Clay-Only Materials..	94
Table B-3: Density Achieved in Small Volume Pouring Tests Using Wyoming Bentonite-Additive Pellets	95
Table B-4: Thermal Properties of Pellets	96
Table B-5: Crush Strength of Clay-Only Pellets.....	107
Table B-6: Crush Strength of Pellets for use as Gap fill in IFB or as Tunnel Fill in HTP Geometry	109

Table B-1: Results of Free Swell Tests

Test #	Group ID	Batch Number	Liquid	TDS (g/L)	Free swell index (cc/2g)	Free swell index (cc/g)
1	100% Wyom. Bent. Wyoming	Pellet 43	DW	0	11.8	5.9
			35 g/L solution	35	7.3	3.7
			70 g/L solution	70	7.5	3.8
			275 g/L solution	275	5.7	2.8
2	90%-10% B-S 10% Sand	Pellet 4	Distilled water	0	16.2	8.1
			35 g/L solution	35	6.4	3.2
			70 g/L solution	70	6.4	3.2
			275 g/L solution	275	5.1	2.6
3	90%-10% B-S 10% Sand	Pellet 47	DW	0	16.5	8.2
			35 g/L solution	35	6.8	3.4
			70 g/L solution	70	6.9	3.4
			275 g/L solution	275	5.4	2.7
4	90%-10% B-S 10% Sand	Pellet 30	DW	0	13.1	6.6
			35 g/L solution	35	6.5	3.3
			70 g/L solution	70	7.2	3.6
			275 g/L solution	275	4.9	2.4
5	90%-10% B-I 10% Illite	Pellet 6	DW	0	12.1	6.0
			35 g/L solution	35	5.9	2.9
			70 g/L solution	70	6.3	3.1
			275 g/L solution	275	4.9	2.5
6	90%-10% B-I 10% Illite	Pellet 46	DW	0	12.2	6.1
			35 g/L solution	35	7.0	3.5
			70 g/L solution	70	6.7	3.3
			275 g/L solution	275	5.6	2.8
7	90%-10% B-I 10% Illite	Pellet 32	DW	0	13.6	6.8
			35 g/L solution	35	6.4	3.2
			70 g/L solution	70	7.1	3.6
			275 g/L solution	275	5.2	2.6
8	75%-25% B-S 25 % Sand	Pellet 5	DW	0	10.8	5.4
			35 g/L solution	35	7.0	3.5
			70 g/L solution	70	7.0	3.5
			275 g/L solution	275	5.9	2.9
9	75%-25% B-S 25 % Sand	Pellet 45	DW	0	10.1	5.0
			35 g/L solution	35	5.4	2.7
			70 g/L solution	70	6.1	3.1
			275 g/L solution	275	4.4	2.2
10	75%-25% B-S 25 % Sand	Pellet 54	DW	0	11.9	5.9
			35 g/L solution	35	6.0	3.0
			70 g/L solution	70	5.9	2.9
			275 g/L solution	275	4.6	2.3

Test #	Group ID	Batch Number	Liquid	TDS (g/L)	Free swell index (cc/2g)	Free swell index (cc/g)
11	75%-25% B-I 25 % Illite	Pellet 9	DW	0	11.1	5.5
			35 g/L solution	35	5.7	2.9
			70 g/L solution	70	7.0	3.5
			275 g/L solution	275	5.0	2.5
12	75%-25% B-I 25 % Illite	Pellet 44	DW	0	10.0	5.0
			35 g/L solution	35	5.5	2.7
			70 g/L solution	70	4.6	2.3
			275 g/L solution	275	4.4	2.2
13	75%-25% B-I 25 % Illite	Pellet 53	DW	0	11.0	5.5
			35 g/L solution	35	5.3	2.7
			70 g/L solution	70	6.0	3.0
			275 g/L solution	275	4.3	2.2
14	50%-50% B-S 50% Sand	Pellet 48	DW	0	11.3	5.6
			35 g/L solution	35	4.1	2.1
			70 g/L solution	70	4.8	2.4
			275 g/L solution	275	3.6	1.8
15	50%-50% B-S 50% Sand	Pellet 40	DW	0	9.9	5.0
			35 g/L solution	35	6.0	3.0
			70 g/L solution	70	5.8	2.9
			275 g/L solution	275	4.4	2.2
16	50%-50% B-I 50% Illite	Pellet 50	DW	0	13.6	6.8
			35 g/L solution	35	4.3	2.2
			70 g/L solution	70	4.9	2.4
			275 g/L solution	275	3.8	1.9
17	50%-50% B-I 50% Illite	Pellet 39	DW	0	12.1	6.1
			35 g/L solution	35	4.8	2.4
			70 g/L solution	70	5.3	2.6
			275 g/L solution	275	4.0	2.0
18	Milos B	Pellet 11	DW	0	9.2	4.6
			35 g/L solution	35	4.2	2.1
			70 g/L solution	70	4.2	2.1
			275 g/L solution	275	3.9	2.0
19	Milos B	Pellet 55	DW	0	8.6	4.3
			35 g/L solution	35	4.6	2.3
			70 g/L solution	70	4.8	2.4
			275 g/L solution	275	3.0	1.5
20	Milos AC200	Pellet 41	DW	0	11.2	5.6
			35 g/L solution	35	6.6	3.3
			70 g/L solution	70	7.2	3.6
			275 g/L solution	275	5.5	2.7

Test #	Group ID	Batch Number	Liquid	TDS (g/L)	Free swell index (cc/2g)	Free swell index (cc/g)
21	Milos AC200	Pellet 52	DW	0	16.3	8.1
			35 g/L solution	35	7.4	3.7
			70 g/L solution	70	7.5	3.8
			275 g/L solution	275	5.7	2.9
22	Asha	Pellet 17	DW	0	10.4	5.2
			35 g/L solution	35	4.6	2.3
			70 g/L solution	70	4.8	2.4
			275 g/L solution	275	3.9	1.9
23	Asha	Pellet 35	DW	0	10.1	5.0
			35 g/L solution	35	4.7	2.3
			70 g/L solution	70	5.0	2.5
			275 g/L solution	275	3.7	1.9
	SKB MX-80 pellets		DW	0	15	7.5
	Posiva Buffer Test		DW	0	13.9	7
	Cebogel		DW	0	16.5	8.3

Note: Bentonite used in production of mixed component pellets is Wyoming bentonite = NSB-BC200-2008

Table B-2: Density Achieved in Small Volume Pouring Tests for Clay-Only Materials

Material	Batch Number	Pellet Size	Roller Load (psi)	Roller Speed Setting	Average Pellet w (%)	Average Pellet ρ_b (g/cc)	Average Pellet ρ_d (g/cc)	Single Pellet EMDD (Mg/m3)	Crush Strength ² (N)	STDEV	Poured Bulk Density (Mg/m3)	Poured Dry Density	Poured EMDD (Mg/m3)	Vibrated Bulk Density	Vibrated Dry Density	Vibrated EMDD (Mg/m3)
Wyoming	1	L	1000	3	6.2	2.07	1.95	1.79	95	±36.6						
Wyoming	2	L	1500	3	6.5	2.13	2.00	1.85	144	±25.7						
Wyoming	56=1/3 HTP	L	1500	3	10	2.11	1.92	1.76	235	±29.8	1.12-1.17	1.02-1.06	0.85-0.88	1.33-1.43	1.21-1.30	1.02-1.11
Wyoming	2010	L	1450		10.0	2.12	1.93	1.77								
Wyoming	3	L	1750	3	7.1	2.16	2.02	1.87	187	±45.4	1.07	1.00	0.83			
Wyoming	2010	L	1800		9.4	2.17	1.98	1.83								
Wyoming	43	M	1500	3	9.6	2.09	1.91	1.76	119	±31.1	1.17-1.30	1.07-1.16	0.89-1.01	1.47	1.34	1.15
Wyoming	18	S	1500	4	7.4	2.23	2.08	1.94	61	±10.0						
Wyoming	19	S	1500	3	7.3	2.24	2.09	1.95	54	±17.7						
Wyoming	51	S	1500	4	9.7	2.18	1.99	1.84	89	±8.2	1.16	1.06	0.88	1.35	1.23	1.04
Wyoming	29	S	1500	3	14.9	2.25	1.96	1.81	78	±21.6	1.19	1.04	0.87	1.39	1.21	1.02
Wyoming	20	S	1750	4	7.2	2.26	2.11	1.98	79	±18.0						
Wyoming	21	S	1750	3	7.3	2.28	2.12	1.99	52	±14.4	1.06	0.99	0.82			
Wyoming	28	S	1750	3	13.8	2.30	2.02	1.85	79	±22.3						
Milos AC200	41	L	1000	3	11.4	2.04	1.83	1.70	113	±14.8	1.05-1.14	0.94-1.02	0.77-0.85	1.29	1.16	0.98
Milos AC200	42	L	1000	4.25	11.7	2.05	1.84	1.71	238	±31.0						
Milos AC200	36	S	1000	3	11.6	2.09	1.87	1.75	50	±20.4						
Milos AC200	37	S	1000	4.25	11.8	2.04	1.82	1.69	72	±9.2	0.94	0.84	0.68			
Milos AC200	52	S	1000	4.25	11.8	2.12	1.90	1.78	85	±11.3	1.08	0.97	0.80	1.21	1.08	0.94
Asha	12	L	750	4.25	13.1	2.09	1.85	1.58	91	±19.4						
Asha	13	L	1000	4.25	13.0	2.17	1.92	1.66	195	±40.8						
Asha	14	L	1000	4	12.8	2.18	1.93	1.67	285	±63.2	1.11	0.98	0.74	1.2	1.06	0.81
Asha	15	L	1000	3.5	13.0	2.18	1.93	1.67	220	±28.0						
Asha	16	L	1250	3.25	13.0	2.23	1.97	1.72	273	±30.2						
Asha	17	L	1250	3.5	12.9	2.20	1.95	1.70	246	±30.4	1.01	0.89	0.67			
Asha	34	S	1250	3	8.6	2.25	2.07	1.84	48	±2.5						
Asha	35	S	1250	3.25	8.6	2.23	2.05	1.82	69	±14.1	1.01-1.11	0.93-1.02	0.70-0.77	1.2	1.10	0.85
Milos B	10	L	1000	3	14.0	2.18	1.91	1.60	299	±36.6						
Milos B	11	L	500	4.25	16.2	2.20	1.89	1.58	261	±11.6	1.07	0.92	0.63	1.29	1.11	0.8
Milos B	22	S	1000	3	13.5	2.24	1.97	1.67	100	±16.0						
Milos B	23	S	500	4.25	14.3	2.30	2.01	1.72	101	±20.2						
Milos B	55	S	1000	4.25	12.6	2.17	1.93	1.62	100	±27.7	1.07-1.10	0.95-0.98	0.65-0.68	1.28	1.14	0.81
Cebogel Extruded *					15.2	1.83	1.59	1.44	170	±50.7	1.04/1.05	0.91	0.87	1.29	1.12	0.98
SKB-MX80 pellets *					9.3	1.84	1.69	1.51	NM	NM	1.1	1.00	0.83	1.244	1.14	0.96
Posiva Buffer Test *					15.6	1.79	1.55	1.36	136	±20.7	1.09-1.13	0.97	0.80	1.31	1.13	0.95

Note: Bentonite used in AECL pellets is Wyoming bentonite = NSB-BC200-2008 *. Materials supplied by SKB and Posiva, different sizes than AECL pellets

Table B-3: Density Achieved in Small Volume Pouring Tests Using Wyoming Bentonite-Additive Pellets

Material Composition	Batch Number	Pellet Size	Roller Load (psi)	Roller Speed Setting	Average Pellet w (%)	Average Pellet ρ_b (g/cc)	Average Pellet ρ_d (g/cc)	Single Pellet EMDD (Mg/m3)	Crush Strength (N)	Strength STDEV	Poured Bulk Density (Mg/m3)	Poured Dry Bulk Density (Mg/m3)	Poured Pellet EMDD (Mg/m3)	Vibrated Bulk Density (Mg/m3)	Vibrated Dry Density (Mg/m3)	Vibrated EMDD (Mg/m3)
Wyoming Bentonite	1	L	1000	3	6.2	2.07	1.95	1.79	95	±36.6						
Wyoming Bentonite	2	L	1500	3	6.5	2.13	2.00	1.85	144	±25.7						
Wyoming Bentonite	2010	L	1500		9.3	2.14	1.96	1.80								
Wyoming Bentonite	56=1/3 HTP	L	1500	3	10	2.11	1.92	1.76	235	±29.8	1.12-1.17	1.02-1.06	0.85-0.88	1.33-1.43	1.21-1.30	1.02-1.11
Wyoming Bentonite	3	L	1750	3	7.1	2.16	2.02	1.87	187	±45.4	1.07	1.00	0.83			
Wyoming Bentonite	2010	L	1800		9.4	2.17	1.98	1.83								
Wyoming Bentonite	43	M	1500	3	9.6	2.09	1.91	1.76	119	±31.1	1.17-1.30	1.07-1.19	0.89-1.01	1.47	1.34	1.15
Wyoming Bentonite	18	S	1500	4	7.4	2.23	2.08	1.94	61	±10.0						
Wyoming Bentonite	19	S	1500	3	7.3	2.24	2.09	1.95	54	±17.7						
Wyoming Bentonite	51	S	1500	4	9.7	2.18	1.99	1.84	89	+8.2	1.16-1.17	1.06	0.88	1.35	1.23	1.04
Wyoming Bentonite	29	S	1500	3	14.9	2.25	1.96	1.81	78	±21.6	1.19	1.04	0.87	1.39	1.21	1.02
Wyoming Bentonite	20	S	1750	4	7.2	2.26	2.11	1.98	79	±18.0						
Wyoming Bentonite	21	S	1750	3	7.3	2.28	2.12	1.99	52	±14.4	1.06	0.99	0.82			
Wyoming Bentonite	28	S	1750	3	13.8	2.30	2.02	1.85	79	±22.3						
10 % Quartz Sand	4	L	1500	3	5.8	2.16	2.04	1.84	217	±25.5						
10 % Quartz Sand	47	M	1500	3	7.5	2.19	2.04	1.84	189	±26.6	1.37-1.49	1.27-1.39	1.02-1.14	1.56	1.45	1.19
10 % Quartz Sand	24	S	1500	3	5.6	2.32	2.20	2.04	116	±7.1						
10 % Quartz Sand	30	S	1500	3	13.7	2.36	2.08	1.89	87	±10.9						
25% Quartz sand	5	L	1500	3	5.6	2.19	2.07	1.77	213	±17.0	1.08-1.16	1.02-1.10	0.69-0.81	1.26-1.33	1.19-1.26	0.83-0.90
25% Quartz sand	45	M	1500	3	6.1	2.20	2.07	1.77	223	±21.3	1.29-1.37	1.22-1.29	0.86-0.92	1.59-1.63	1.50-1.54	1.12-1.16
25% Quartz sand	25	S	1500	3	4.6	2.27	2.17	1.91	95	+9.4	1.06	1.01	0.68			
25% Quartz sand	54	S	1500	4	7.1	2.27	2.12	1.84	169	±25.7	1.21	1.13	0.78	1.4	1.31	0.94
25% Quartz sand	31	S	1500	3	14.3	2.35	2.06	1.76	119	+9.6						
50% Quartz sand	48	M	1750	3	3.9	2.29	2.20	1.72	190	±37.2						
50% Quartz sand	40	S	1750	3	3.6	2.04	1.97	1.38	65	±13.7	1.26	1.22	0.64	1.37	1.32	0.72
10% Illite	6	L	1500	3	5.2	2.14	2.03	1.82	239	±34.6						
10% Illite	7	L	1750	3	5.3	2.13	2.02	1.81	100	±28.8	1.23	1.17	0.92	1.41	1.34	1.08
10% Illite	46	M	1500	3	7.8	2.15	1.99	1.78	149	±31.3	1.32	1.22	0.94	1.33	1.23	0.94
10% Illite	26	S	1500	3	4.9	2.41	2.30	2.16	67	±22.6						
10% Illite	32	S	1500	3	14.3	2.21	1.93	1.71	95	±20.6						
25% Illite	8	L	1500	3	4.1	2.10	2.02	1.70	101	±14.0	1.14	1.10	0.79	1.31	1.26	0.89
25% Illite	9	L	1750	3	4.3	2.18	2.09	1.79	166	+80.0	1.02	0.98	0.66			
25% Illite	44	M	1500	3	4.7	2.05	1.96	1.62	136	±19.6	1.18	1.13	0.78	1.29	1.23	0.87
25% Illite	27	S	1750	3	3.9	2.15	2.07	1.76	39	+8.9						
25% Illite	33	S	1750	3	13.9	2.20	1.93	1.59	92	+8.3	1.02	0.90	0.65			
25% Illite	53	S	1000	4	10.2	2.23	2.02	1.70	129	±14.5	1.13-1.16	0.87	0.57	1.35	1.23	0.87
50% Illite	49	M	1500	3	5.6	2.09	1.98	1.38	85	±15.0	1.21	1.15	0.59	1.36	1.29	0.69
50% Illite	50	M	1750	3	5.6	2.21	2.09	1.53	179	±14.3						
50% Illite	38	S	1500	3	4.6	2.22	2.12	1.57	78	±31.0	1.17	1.12	0.57	1.36	1.30	0.7
50% Illite	39	S	1750	3	4.6	2.23	2.13	1.59	72	±13.9						

Note: Bentonite used in production of mixed component pellets is Wyoming bentonite = NSB-BC200-2008

Table B-4: Thermal Properties of Pellets

(Note: TC = Thermal Conductivity, TD = Thermal Diffusivity, SH = Specific Heat)

Batch	Rep	Poured			Vibrated			Mass of Pellets (kg)	ρ_{bulk} (Mg/m ³)
		TC (W/(m·K))	TD (mm ² /s)	SH (Mj/m ³ K)	TC (W/(m·K))	TD (mm ² /s)	SH (Mj/m ³ K)		
100% Wyoming Bentonite - Large									
56	1	0.295	4.764	0.062				1.792	1.179
	2	0.223	1.854	0.120				1.760	1.158
	3	0.307	4.963	0.062				1.816	1.195
	Average:	0.275	3.860	0.081					1.177
	1				0.318	8.046	0.040	2.035	1.339
	2				0.365	9.976	0.037	2.019	1.328
	3				0.347	6.240	0.056	1.988	1.308
	Average:				0.344	8.087	0.044		1.325
100% Wyoming Bentonite - Medium									
43	1	0.360	1.843	0.196				1.341	1.355
	2	0.449	3.271	0.137				1.219	1.232
	3	0.431	6.341	0.068				1.228	1.240
	Average:	0.414	3.818	0.134					1.276
	1				0.586	2.722	0.215	1.447	1.462
	2				0.583	3.713	0.157	1.466	1.481
	3				0.600	1.768	0.339	1.463	1.478
	Average:				0.590	2.734	0.237		1.474
100% Wyoming Bentonite - Small									
29	1	0.363	2.370	0.153				1.800	1.184
	2	0.319	1.854	0.172				1.817	1.195
	Average:	0.341	2.112	0.163					1.190
	1				0.592	2.598	0.228	2.111	1.389
	2				0.634	2.855	0.222	2.107	1.386
	Average:				0.613	2.727	0.225		1.388

Batch	Rep	Poured			Vibrated			Mass of Pellets (kg)	ρ_{bulk} (Mg/m ³)
		TC (W/(m·K))	TD (mm ² /s)	SH (Mj/m ³ K)	TC (W/(m·K))	TD (mm ² /s)	SH (Mj/m ³ K)		
100% Wyoming Bentonite - Small									
51	1	0.424	1.683	0.252				1.768	1.163
	2	0.513	2.146	0.239				1.723	1.133
	3	0.425	1.032	0.412				1.778	1.170
	Average:	0.454	1.620	0.301					1.155
100% Wyoming Bentonite - Large									
	1	0.425	1.253	0.339				4.675	1.172
	2	0.455	1.126	0.404				4.675	1.172
	3	0.462	1.434	0.322				4.675	1.172
	Average:	0.447	1.271	0.355					1.172
100% Wyoming Bentonite Using Different Sized Testing Boxes									
	1				0.522	1.246	0.419	5.400	1.353
	1				0.491	0.614	0.800	2.072	1.363
	2				0.498	1.327	0.375	2.044	1.345
	Average:				0.503	1.062	0.531		1.354
100% Wyoming Bentonite - Large, with 20% Bentonite Fines									
56	1				0.658	2.292	0.288	2.400	1.579
	2				0.644	1.854	0.364	2.400	1.579
	Average:				0.651	2.073	0.326		1.579
100% Wyoming Bentonite - Large, with 30% Bentonite Fines									
56	1				0.697	1.491	0.468	2.600	1.711
	2				0.652	1.803	0.361	2.600	1.711
	3				0.657	1.193	0.551	2.600	1.711
	Average:				0.669	1.496	0.460		1.711

Batch	Rep	Poured			Vibrated			Mass of Pellets (kg)	ρ_{bulk} (Mg/m ³)
		TC (W/(m·K))	TD (mm ² /s)	SH (Mj/m ³ K)	TC (W/(m·K))	TD (mm ² /s)	SH (Mj/m ³ K)		
100% Wyoming Bentonite - Small, with 30% Bentonite Fines									
29	1				0.628	0.697	0.901	2.730	1.796
	2				0.599	0.732	0.819	2.730	1.796
	3				0.620	0.662	0.936	2.730	1.796
	Average:				0.616	0.697	0.885		1.796
100% Wyoming Bentonite - Small, with 30% Bentonite Fines									
51	1				0.696	1.143	0.609	2.730	1.796
	2				0.696	1.324	0.525	2.730	1.796
	3				0.676	0.925	0.731	2.730	1.796
	Average:				0.689	1.131	0.622		1.796
Asha - Large									
14 & 15	1	0.406	0.268	0.152				1.697	1.116
	2	0.446	3.547	0.126				1.691	1.113
	Average:	0.426	1.908	0.139					1.114
	1				0.543	2.236	0.243	1.958	1.288
	2				0.541	4.564	0.119	1.948	1.282
	Average:				0.542	3.400	0.181		1.285
Asha - Small									
34 & 35	1	0.405	3.929	0.103				1.693	1.114
	2	0.446	1.923	0.232				1.684	1.108
	Average:	0.425	2.926	0.167					1.111
	1				0.458	1.178	0.389	1.825	1.201
	2				0.528	1.554	0.340	1.834	1.207
	Average:				0.493	1.366	0.364		1.204

Batch	Rep	Poured			Vibrated			Mass of Pellets (kg)	ρ_{bulk} (Mg/m ³)
		TC (W/(m·K))	TD (mm ² /s)	SH (Mj/m ³ K)	TC (W/(m·K))	TD (mm ² /s)	SH (Mj/m ³ K)		
Milos AC200 - Large									
41 & 42	1	0.454	4.640	0.098				1.732	1.139
	2	0.438	4.828	0.091				1.732	1.140
	Average:	0.446	4.734	0.094					1.140
	1				0.604	1.928	0.313	1.978	1.301
	2				0.618	2.580	0.240	1.957	1.287
	Average:				0.611	2.254	0.276		1.294
Milos AC200 - Small									
52	1	0.441	1.959	0.225				1.638	1.078
	2	0.435	2.371	0.184				1.628	1.071
	3	0.434	2.367	0.183				1.635	1.076
	Average:	0.436	2.232	0.197					1.075
	1				0.542	2.427	0.223	1.866	1.227
	2				0.543	2.152	0.252	1.813	1.193
	3				0.538	2.284	0.235	1.859	1.223
	Average:				0.541	2.288	0.237		1.214
Milos B - Large									
11	1	0.439	5.456	0.081				1.595	1.049
	2	0.426	4.945	0.086				1.665	1.095
	Average:	0.433	5.201	0.083					1.072
	1				0.622	2.478	0.251	1.922	1.264
	2				0.645	2.673	0.241	1.983	1.305
	Average:				0.634	2.576	0.246		1.285

Batch	Rep	Poured			Vibrated			Mass of Pellets (kg)	ρ_{bulk} (Mg/m ³)
		TC (W/(m·K))	TD (mm ² /s)	SH (Mj/m ³ K)	TC (W/(m·K))	TD (mm ² /s)	SH (Mj/m ³ K)		
Milos B - Small									
55	1	0.472	1.230	0.384				1.634	1.075
	2	0.472	2.438	0.194				1.698	1.117
	3	0.468	1.863	0.251				1.671	1.099
	Average:	0.471	1.844	0.276					1.097
	1				0.609	1.710	0.356	1.958	1.288
	2				0.585	2.162	0.271	1.956	1.287
	3				0.557	1.803	0.309	1.925	1.267
	Average:				0.584	1.892	0.312		1.280
	90% Wyoming Bentonite:10% Silica Sand - Medium								
47	1	0.441	5.348	0.082				0.861	1.471
	2	0.432	10.190	0.042				0.865	1.479
	3	0.490	4.979	0.098				0.886	1.514
	Average:	0.454	6.839	0.074					1.488
	1				0.684	2.366	0.289	1.016	1.737
	2				0.576	2.740	0.210	1.010	1.726
	3				0.584	1.794	0.326	1.009	1.725
	Average:				0.614	2.300	0.275		1.729
	90% Wyoming Bentonite:10% Silica Sand - Medium, with 30% Bentonite Fines								
47	1				0.515	2.743	0.188	1.300	2.222
	2				0.518	3.478	0.149	1.300	2.222
	3				0.514	2.790	0.184	1.300	2.222
	Average:				0.516	3.004	0.174		2.222

Batch	Rep	Poured			Vibrated			Mass of Pellets (kg)	ρ_{bulk} (Mg/m ³)
		TC (W/(m·K))	TD (mm ² /s)	SH (Mj/m ³ K)	TC (W/(m·K))	TD (mm ² /s)	SH (Mj/m ³ K)		
75% Wyoming Bentonite:25% Silica Sand - Large									
5	1	0.550	1.824	0.300				1.535	1.077
	2	0.588	6.321	0.093				1.532	1.075
	3	0.548	4.688	0.117				1.530	1.074
	Average:	0.562	4.278	0.170					1.076
	1				0.562	1.833	0.307	2.060	1.445
	2								
	3								
	Average:				0.562	1.833	0.307		1.445
75% Wyoming Bentonite:25% Silica Sand - Medium									
45	1	0.390	7.751	0.050				0.878	1.501
	2	0.481	1.326	0.363				0.875	1.496
	3	0.484	5.460	0.089				0.876	1.497
	Average:	0.452	4.846	0.167					1.498
	1				0.583	2.663	0.219	0.963	1.646
	2				0.561	4.526	0.124	0.949	1.623
	3				0.622	2.231	0.279	0.944	1.614
	Average:				0.588	3.140	0.207		1.628
75% Wyoming Bentonite:25% Silica Sand - Small									
54	1	0.436	1.349	0.323				1.807	1.189
	2	0.440	1.055	0.417				1.861	1.224
	3	0.446	1.231	0.362				1.841	1.211
	Average:	0.441	1.212	0.368					1.208
	1				0.496	0.992	0.500	2.087	1.373
	2				0.561	1.638	0.343	2.142	1.409
	3				0.510	1.051	0.485	2.143	1.410
	Average:				0.522	1.227	0.443		1.397

Batch	Rep	Poured			Vibrated			Mass of Pellets (kg)	ρ_{bulk} (Mg/m ³)
		TC (W/(m·K))	TD (mm ² /s)	SH (Mj/m ³ K)	TC (W/(m·K))	TD (mm ² /s)	SH (Mj/m ³ K)		
50% Wyoming Bentonite: 50% Silica Sand - Small									
40	1	0.461	2.361	0.195				0.596	1.419
	2	0.430	2.669	0.161				0.607	1.446
	3	0.421	1.299	0.324				0.604	1.438
	Average:	0.438	2.110	0.227					1.434
	1				0.549	1.270	0.432	0.722	1.718
	2				0.494	1.119	0.441	0.694	1.652
	3				0.509	1.474	0.345	0.681	1.621
	Average:				0.517	1.288	0.406		1.664
90% Wyoming Bentonite:10% Illite - Large									
7	1	0.397	5.262	0.075				1.784	1.239
	2	0.390	7.157	0.055				1.744	1.211
	Average:	0.394	6.210	0.065					1.225
	1				0.479	6.246	0.077	2.031	1.410
	2				0.494	2.851	0.173	2.032	1.411
	Average:				0.487	4.549	0.125		1.411
90% Wyoming Bentonite:10% Illite - Medium									
46	1	0.440	4.869	0.090				0.774	1.323
	2	0.490	3.034	0.161				0.771	1.318
	3	0.553	3.286	0.168				0.772	1.320
	Average:	0.494	3.730	0.140					1.320
	1				0.543	2.496	0.217	0.789	1.349
	2				0.635	2.474	0.257	0.790	1.351
	3				0.504	3.182	0.158	0.762	1.302
	Average:				0.561	2.717	0.211		1.334

Batch	Rep	Poured			Vibrated			Mass of Pellets (kg)	ρ_{bulk} (Mg/m ³)
		TC (W/(m·K))	TD (mm ² /s)	SH (Mj/m ³ K)	TC (W/(m·K))	TD (mm ² /s)	SH (Mj/m ³ K)		
75% Wyoming Bentonite:25% Illite - Large									
8	1	0.409	4.493	0.091				1.750	1.151
	2	0.359	5.226	0.069				1.701	1.119
	Average:	0.384	4.860	0.080					1.135
	1				0.474	4.823	0.098	1.996	1.313
	2				0.508	1.952	0.260	1.970	1.296
	Average:				0.491	3.388	0.179		1.305
75% Wyoming Bentonite : 25% Illite - Medium Pellets									
44	1	0.413	3.182	0.130				0.791	1.351
	2	0.399	4.470	0.089				0.793	1.356
	3	0.404	5.183	0.078				0.819	1.400
	Average:	0.405	4.278	0.099					1.369
	1				0.506	1.211	0.418	0.899	1.537
	2				0.522	1.145	0.456	0.893	1.526
	3				0.547	1.620	0.338	0.877	1.499
	Average:				0.525	1.325	0.404		1.520
75% Wyoming Bentonite:25% Illite - Small									
53	1	0.407	1.386	0.294				1.774	1.167
	2	0.434	2.677	0.162				1.760	1.158
	3	0.426	1.594	0.267				1.766	1.162
	Average:	0.422	1.886	0.241					1.162
	1				0.467	0.913	0.512	2.009	1.322
	2				0.483	0.933	0.517	2.054	1.351
	3				0.494	0.956	0.517	2.076	1.365
	Average:				0.481	0.934	0.515		1.346

Batch	Rep	Poured			Vibrated			Mass of Pellets (kg)	ρ_{bulk} (Mg/m ³)
		TC (W/(m·K))	TD (mm ² /s)	SH (Mj/m ³ K)	TC (W/(m·K))	TD (mm ² /s)	SH (Mj/m ³ K)		
75% Wyoming Bentonite:25% Illite - Large, with 30% Bentonite Fines									
8	1				0.538	0.884	0.609	2.600	1.711
	2				0.552	2.024	0.273	2.600	1.711
	3				0.531	1.275	0.416	2.600	1.711
	Average:				0.540	1.394	0.433		1.711
50% Wyoming Bentonite:50% Illite - Medium									
49 & 50	1	0.546	5.871	0.093				1.829	1.203
	2	0.602	3.466	0.174				1.823	1.200
	3	0.424	8.306	0.051				1.854	1.220
	4	0.461	2.616	0.176				1.831	1.205
	Average:	0.508	5.065	0.124					1.207
	1				0.523	1.629	0.321	2.084	1.371
	2				0.523	1.067	0.490	2.047	1.347
	Average:				0.523	1.348	0.406		1.359
50% Wyoming Bentonite:50% Illite - Small									
38 & 39	1	0.461	3.221	0.143				1.783	1.173
	2	0.456	3.450	0.132				1.782	1.173
	Average:	0.459	3.336	0.138					1.173
	1				0.517	1.817	0.285	2.082	1.370
	2				0.512	1.793	0.296	2.059	1.355
	Average:				0.514	1.805	0.290		1.362
Buffer Test Pellets: Trial #1									
	1	0.571	2.150	0.265					1.102
	2	0.496	2.931	0.169					1.101
	3	0.519	1.951	0.266					1.100
	4	0.461	4.688	0.098					1.100
	Average:	0.512	2.930	0.200					1.101

Batch	Rep	Poured			Vibrated			Mass of Pellets (kg)	ρ_{bulk} (Mg/m ³)
		TC (W/(m·K))	TD (mm ² /s)	SH (Mj/m ³ K)	TC (W/(m·K))	TD (mm ² /s)	SH (Mj/m ³ K)		
Buffer Test Pellets: Trial #2									
	1	0.520	2.712	0.235				1.663	1.094
	2	0.513	5.126	0.100				1.672	1.100
	Average:	0.517	3.919	0.168					1.097
	1				0.540	1.255	0.430	1.924	1.266
	2				0.585	1.182	0.495	1.981	1.303
	Average:				0.562	1.219	0.462		1.284
Buffer Test Pellets: Trial #3; mc=15.6%									
	1	0.297	1.648	0.18					1.133
	2	0.333	2.151	0.155					1.132
	3	0.264	1.103	0.240					1.124
	Average	0.287	1.634	0.192					1.130
	1				0.622	2.69	0.231		1.294
	2				0.658	2.569	0.256		1.290
	3				0.664	2.397	0.277		1.286
	Average				0.648	2.552	0.255		1.290
Cebogel	mc=15.2%								
	1	0.501	2.553	0.196					1.133
	2	0.500	1.794	0.279					1.132
	3	0.521	1.687	0.309					1.124
	Average	0.503	2.011	0.261					1.130
					0.602	1.578	0.382		1.294
					0.604	1.353	0.447		1.290
					0.616	1.694	0.364		1.286
	Average				0.607	1.542	0.398		1.290

Batch	Rep	Poured			Vibrated			Mass of Pellets (kg)	ρ_{bulk} (Mg/m ³)
		TC (W/(m·K))	TD (mm ² /s)	SH (Mj/m ³ K)	TC (W/(m·K))	TD (mm ² /s)	SH (Mj/m ³ K)		
SKB-MX80	mc=9.3%								
	1	0.360						1.086	
	2	0.390						1.100	
	3	0.329						1.100	
	Average	0.360						1.095	
	1				0.505	3.672	0.138	1.233	
	2				0.425	2.193	0.194	1.256	
	3				0.440	1.359	0.323	1.243	
	Average				0.457	2.408	0.218	1.244	

Table B-5: Crush Strength of Clay-only Pellets

	Batch No.	Size	Water Content %	Dry Density Mg/m³	Crush Strength N	STDEV
100% Wyoming	1	L	6.2	1.9	95	37
100% Wyoming	2	L	6.5	2.0	144	26
100% Wyoming	3	L	7.1	2.0	187	45
		Average	6.6	2.0	142	52
100% Wyoming	56	L	10	1.9	235	30
Milos AC200	41	L	11.4	1.8	113	15
Milos AC200	42	L	11.7	1.8	238	31
		Average	11.6	1.8	175	70
Milos B	10	L	14.0	1.9	299	37
Milos B	11	L	16.2	1.9	261	12
		Average	15.1	1.9	280	32
Asha	12	L	13.1	1.8	91	19
Asha	13	L	13.0	1.9	195	41
Asha	14	L	12.8	1.9	285	63
Asha	15	L	13.0	1.9	220	28
Asha	16	L	13.0	2.0	273	30
Asha	17	L	12.9	1.9	246	30
		Average	13.0	1.9	215	73
Cebogel			15.2	1.59	170	51
Buffer Test - MX-80			15.6	1.55	136	21

Note: Wyoming bentonite = NSB-BC200-2008

Table B-5: Crush Strength of Clay-only Pellets (continued)

	Batch No.	Size	Water Content %	Dry Density Mg/m³	Crush Strength N	STDEV
100% Wyoming	18	S	7.4	2.08	61	10
100% Wyoming	19	S	7.3	2.09	54	18
100% Wyoming	20	S	7.2	2.11	78	18
100% Wyoming	21	S	7.3	2.12	52	14
		Average	7.3	2.1	61	17
100% Wyoming	28	S	13.8	2.02	79	22
100% Wyoming	29	S	14.9	1.96	78	22
		Average	14.4	2.0	79	20
100% Wyoming	51	S	9.7	1.99	89	8
Milos AC200	36	S	11.6	1.87	50	20
Milos AC200	37	S	11.8	1.82	72	9
Milos AC200	52	S	11.8	1.90	85	11
		Average	11.7	1.9	69	20
Asha	34	S	8.6	2.07	48	3
Asha	35	S	8.6	2.05	69	14
		Average	8.6	2.1	59	15
Milos B	22	S	13.5	1.97	100	16
Milos B	23	S	14.3	2.01	101	20
Milos B	55	S	12.6	1.93	100	28
		Average	13.5	2.0	101	20

Note: Wyoming bentonite = NSB-BC200-2008

Table B-6: Crush Strength of Pellets for use as Gap Fill in IFB or as Tunnel Fill in HTP Geometry

	Batch No.	Size	Water Content %	Dry Density Mg/m³	Crush Strength N	STDEV
100% Wyoming	1	L	6.2	1.9	95	37
100% Wyoming	2	L	6.5	2.0	144	26
100% Wyoming	3	L	7.1	2.0	187	45
		Average	6.6	2.0	142	52
100% Wyoming	56	L	10	1.9	235	30
10% Sand	4	L	5.8	2.0	217	25
25% Sand	5	L	5.6	2.1	213	17
10% Illite	6	L	5.2	2.0	239	35
10% Illite	7	L	5.3	2.0	100	29
		Average	5.3	2.0	169	80
25% Illite	8	L	4.1	2.0	101	14
25% Illite	9	L	4.3	2.1	166	80
		Average	4.2	2.1	133	63
100% Wyoming	43	M	9.6	1.9	119	31
10% Sand	47	M	7.5	2.0	189	27
25% Sand	45	M	6.1	2.1	223	21
50% Sand	48	M	3.9	2.2	190	37
10% Illite	46	M	7.8	2.0	149	31
25% Illite	44	M	4.7	2.0	136	20
50% Illite	49	M	5.6	2.0	85	15
50% Illite	50	M	5.6	2.1	179	14
		Average	5.6	2.0	132	52

Note: Wyoming bentonite = NSB-200-2008

Table B-6: Crush Strength of Pellets for use as Gap Fill in IFB or as Tunnel Fill in HTP Geometry (continued)

	Batch No.	Size	Water Content (%)	Dry Density (Mg/m³)	Crush Strength (N)	STDEV (N)
100% Wyoming	18	S	7.4	2.1	61	10
100% Wyoming	19	S	7.3	2.1	54	18
100% Wyoming	20	S	7.2	2.1	78	18
100% Wyoming	21	S	7.3	2.1	52	14
		Average	7.3	2.1	61	17
100% Wyoming	28	S	13.8	2.0	79	22
100% Wyoming	29	S	14.9	2.0	78	22
		Average	14.4	2.0	79	20
100% Wyoming	51	S	9.7	2.0	89	8
10% Sand	24	S	5.6	2.2	116	7
10% Sand	30	S	13.7	2.1	87	11
25% Sand	25	S	4.6	2.2	95	9
25% Sand	54	S	7.1	2.1	169	26
25% Sand	31	S	14.3	2.1	119	10
50% Sand	40	S	3.6	2.0	65	14
10% Illite	26	S	4.9	2.3	67	23
10% Illite	32	S	14.3	1.9	95	21
25% Illite	27	S	3.9	2.1	39	9
25% Illite	33	S	13.9	1.9	92	8
25% Illite	53	S	10.2	2.0	129	15
50% Illite	38	S	4.6	2.1	78	31
50% Illite	39	S	4.6	2.1	72	14
		Average	4.6	2.1	75	22

Note: Wyoming bentonite = BC- NSB-200-2008