

# Generic Transportation Worker Dose Assessment

NWMO TR-2014-17

December 2014

**U. Stahmer**

Nuclear Waste Management Organization

**nwmo**

NUCLEAR WASTE  
MANAGEMENT  
ORGANIZATION

SOCIÉTÉ DE GESTION  
DES DÉCHETS  
NUCLÉAIRES

**Nuclear Waste Management Organization**  
22 St. Clair Avenue East, 6<sup>th</sup> Floor  
Toronto, Ontario  
M4T 2S3  
Canada

Tel: 416-934-9814  
Web: [www.nwmo.ca](http://www.nwmo.ca)

# **Generic Transportation Worker Dose Assessment**

**NWMO TR-2014-17**

December 2014

**U. Stahmer**  
Nuclear Waste Management Organization

**Document History**

Title:	Generic Transportation Worker Dose Assessment	
Report Number:	NWMO TR-2014-17	
Revision:	R000	Date: December 2014
Nuclear Waste Management Organization		
Authored by:	U. Stahmer	
Verified by:	C. Lawrence	
Reviewed by:	C. Medri	
Reviewed by:	N. Hunt	
Approved by:	R. Ross	
Accepted by:	C. Hatton	

## ABSTRACT

**Title:** Generic Transportation Worker Dose Assessment  
**Report No.:** NWMO TR-2014-17  
**Author(s):** U. Stahmer  
**Company:** Nuclear Waste Management Organization  
**Date:** December 2014

### Abstract

In 2012, NWMO prepared a generic dose assessment which estimated radiological dose to members of the public due to the used fuel transportation program. The assessment looked at used fuel transport by the two land modes of transport, road and rail. Building on this work, this assessment looks at occupational dose due to used fuel transport.

This work provides a generic assessment of the potential occupational dose to transportation workers due to used fuel transport in Canada. As the location of the APM repository site is currently unknown, program specific calculations and risk assessments are premature. The intent of this assessment is to provide a starting point to address concerns about the safety of the transportation system in a transparent manner.

Transportation activities assessed in this report focus on activities workers are engaged in from the time a used nuclear fuel shipment departs from the reactor sites where the fuel is currently stored to its arrival at the repository site. Occupational doses were assessed to range between approximately 0.012 to 0.35 mSv per year with members of the transport crew receiving the highest dose. Since calculated doses remain below the regulatory dose limit of 1 mSv per year for a member of the public, this assessment concludes that transportation workers would not need to be designated as Nuclear Energy Workers. Findings for different transportation worker categories are tabulated in Figure S-1.

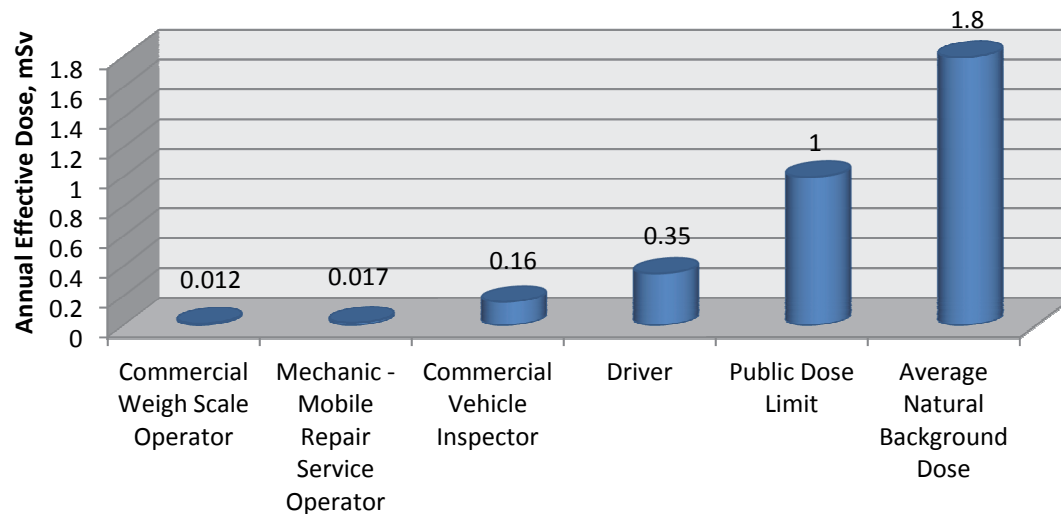

**Figure S-1: Comparison of Worker Doses**



## ACRONYMS AND DEFINITIONS

ALARA	As Low As Reasonably Achievable. An optimization tool in radiation protection used to keep individual, workplace and public dose limits as low as reasonably achievable, social and economic factors being taken into account. ALARA is not a dose limit; it is a practice that aims to keep dose levels as far as possible below regulatory limits.
APM	Adaptive Phased Management. Canada's plan for long-term management of used nuclear fuel.
Burnup	A measure of how much energy has been extracted from a fuel bundle.
CANDU	CANada Deuterium Uranium. Canadian-invented, pressurized heavy water reactor. The acronym refers to its deuterium-oxide (heavy water) moderator and its use of natural uranium fuel.
CNSC	Canadian Nuclear Safety Commission. Canada's nuclear regulatory agency.
Conveyance	Any vehicle such as a truck, train or ship used to transport radioactive material.
CVSA	Commercial Vehicle Safety Alliance. An international not-for-profit organization comprised of local, state, provincial, territorial and federal motor carrier safety officials and industry representatives from the United States, Canada, and Mexico.
DGR	Deep Geological Repository as it applies to used fuel.
Effective Dose	The sum of the products, in sieverts, obtained by multiplying the equivalent dose of radiation received by and committed to each organ or tissue, as set out in CNSC's Radiation Protection Regulations.
Equivalent Dose	The product, in sieverts, obtained by multiplying the absorbed dose of radiation type, as set out in CNSC's Radiation Protection Regulations.
IAEA	International Atomic Energy Agency. United Nations nuclear regulatory authority.
ICRP	International Commission on Radiological Protection. An advisory body providing recommendations and guidance on radiation protection.
MCNP	Monte Carlo N-Particle Transport Code. The software code used to calculate dose rates emitted by the UFTP. See Section 3.2 and Appendix A.
NEW	Nuclear Energy Worker. A person who is required, in the course of the person's business or occupation in connection with a nuclear substance or nuclear facility, to perform duties in such circumstances that there is a reasonable probability that the person may receive a dose of radiation that is greater than the prescribed limit for the general public.
Sv	Sievert. A sievert is the International System of Units (SI) used to measure radiation dose. The unit as used in this assessment is the millisievert (mSv), or one thousandth ( $1/1000$ ) of a sievert (Sv).

Type B(U)	The type of package required for the transport of highly radioactive material including used nuclear fuel. The concept of a Type B(U) package is that it is capable of withstanding most of the severe accident conditions in transport without loss of containment or increase in external radiation level to an extent which would endanger the general public or those involved in rescue or cleanup operations.
UFTP	Used Fuel Transportation Package. The transportation package used to assess the radiation dose reported in this study. The UFTP is currently certified by the CNSC as a Type B(U) package.



**TABLE OF CONTENTS**

	<b><u>Page</u></b>
<b>ABSTRACT</b> .....	<b>iii</b>
<b>1. INTRODUCTION</b> .....	<b>1</b>
<b>1.1 ASSESSMENT PURPOSE</b> .....	<b>1</b>
<b>1.2 ASSESSMENT SCOPE</b> .....	<b>1</b>
<b>1.3 ASSESSMENT BASIS</b> .....	<b>2</b>
<b>2. RADIATION AND RADIOLOGICAL REGULATORY CONTEXT</b> .....	<b>3</b>
<b>2.1 RADIATION</b> .....	<b>3</b>
<b>2.2 REGULATORY CONTEXT</b> .....	<b>3</b>
2.2.1 Regulatory Dose Limits .....	3
2.2.2 Maximum Radiation Levels .....	4
<b>3. ASSUMPTIONS AND ANALYSIS METHODOLOGY</b> .....	<b>5</b>
<b>3.1 USED FUEL TRANSPORTATION PACKAGE</b> .....	<b>5</b>
3.1.1 Used Fuel Properties.....	5
3.1.2 Weather Cover (Neutron Shield) .....	6
3.1.3 Road Transport Configuration .....	6
<b>3.2 UFTP DOSE RATES AND MAXIMUM RADIATION LEVELS</b> .....	<b>7</b>
3.2.1 Maximum Dose Rates .....	8
<b>4. TRANSPORTATION ACTIVITIES</b> .....	<b>10</b>
<b>4.1 DRIVER</b> .....	<b>11</b>
4.1.1 Pre-Driving Activities .....	12
4.1.2 En-route Activities.....	13
4.1.2.1 Driving .....	13
4.1.2.2 Stops during Driving .....	15
4.1.3 Post-Driving Activities.....	17
4.1.4 Driver Activity Summary .....	17
4.1.5 Time per Shipment and Maximum Annual Shipments per Driver.....	18
<b>4.2 PROVINCIAL COMMERCIAL VEHICLE INSPECTOR</b> .....	<b>19</b>
<b>4.3 COMMERCIAL WEIGH SCALE OPERATOR</b> .....	<b>20</b>
<b>4.4 MECHANIC – MOBILE REPAIR SERVICE OPERATOR</b> .....	<b>21</b>
<b>5. ILLUSTRATIVE OCCUPATIONAL DOSE</b> .....	<b>21</b>
<b>5.1 DRIVER</b> .....	<b>22</b>
<b>5.2 COMMERCIAL VEHICLE INSPECTOR</b> .....	<b>23</b>
<b>5.3 COMMERCIAL WEIGH SCALE OPERATOR</b> .....	<b>23</b>
<b>5.4 MECHANIC – MOBILE REPAIR SERVICE</b> .....	<b>25</b>
<b>6. DISCUSSION OF RESULTS</b> .....	<b>25</b>
<b>6.1 DRIVER</b> .....	<b>25</b>
6.1.1 Data Sensitivity.....	25
<b>6.2 COMMERCIAL VEHICLE INSPECTOR</b> .....	<b>26</b>
<b>6.3 COMMERCIAL WEIGH SCALE OPERATOR</b> .....	<b>27</b>
<b>6.4 MECHANIC – MOBILE REPAIR SERVICE OPERATOR</b> .....	<b>27</b>

<b>7.</b>	<b>CONCLUSIONS .....</b>	<b>27</b>
	<b>ACKNOWLEDGEMENTS .....</b>	<b>30</b>
	<b>REFERENCES .....</b>	<b>31</b>
	<b>APPENDIX A: RATIONALE FOR LIMITING SCOPE TO WORKERS WITHIN 30 M OF PACKAGE .....</b>	<b>33</b>
	<b>APPENDIX B: TRANSPORT ACTIVITIES AND DOSE CALCULATIONS .....</b>	<b>35</b>
	<b>APPENDIX C: CALCULATION OF DOSE TO INDIVIDUAL DUE TO PASSING UFTP SHIPMENT .....</b>	<b>59</b>
	<b>APPENDIX D: RATIONALE FOR LIMITING SCOPE TO ROAD TRANSPORT .....</b>	<b>63</b>

**LIST OF TABLES**

	<b><u>Page</u></b>
Table 1: Regulatory Effective Dose Limits .....	3
Table 2: Maximum Dose Rates from UFTP (without Weather Cover) .....	8
Table 3: Dose Rates from UFTP.....	8
Table 4: Transportation Activities and Associated Workers.....	11
Table 5: Transport Speed Limits in Population Density Zones .....	15
Table 6: Distances and Travel Times through Population Density Zones .....	16
Table 7: Pre- and Post-Shipment Activities .....	18
Table 8: Stop Durations and Frequencies .....	18
Table 9: Maximum Annual Shipments per Driver .....	19
Table 10: Driver Dose Summary.....	22
Table 11: Commercial Vehicle Inspector Dose.....	23
Table 12: Weigh Scale Operator Dose .....	24
Table 13: Data Sensitivity to Transport Speed and Rest Stop Length.....	26
Table 14: Maximum Inspections for a Given Inspector.....	26
Table 15: Occupational Dose Summary .....	28

**LIST OF FIGURES**

	<b><u>Page</u></b>
Figure 1: Maximum Radiation Levels for Packages and Conveyances Transported under Exclusive Use .....	4
Figure 2: UFTP Assembly.....	6
Figure 3: Typical Road Transport Configuration .....	7
Figure 4: Maximum Dose Rates from UFTP (220 MWh/kgU).....	9
Figure 5: Maximum Dose Rates from UFTP (280 MWh/kgU).....	10
Figure 6: Driver Connecting Tractor to Trailer .....	12
Figure 7: Transport Crew in Tractor Cab during Driving .....	13
Figure 8: Sample Population Density Zone Map .....	14
Figure 9: Commercial Cardlock Station on Highway 17 .....	17
Figure 10: Commercial Vehicle Circle Check .....	20
Figure 11: UFTP Shipment in Stationary Weigh Scale.....	21
Figure 12: MTO Weigh Station and MTO Officer using a Portable Scale.....	24
Figure 13: Comparison of Worker Doses.....	28



## **1. INTRODUCTION**

Used nuclear fuel discharged from Canadian nuclear power reactors is currently stored at licensed interim storage facilities located at the reactor sites where it is produced. Adaptive Phased Management (APM), Canada's plan for long-term management of used nuclear fuel has as its endpoint safe and secure isolation of used nuclear fuel in a deep geological repository (DGR). Implementation of APM requires the transport of the used nuclear fuel from the interim storage locations to the repository site.

In 2012, NWMO prepared a generic dose assessment (Batters et al., 2012) which estimated radiological dose to members of the public due to the used fuel transportation program. The assessment looked at used fuel transport by the two land modes of transport: road and rail. Building on the work done in 2012, this assessment looks at occupational dose due to used fuel transport.

### **1.1 Assessment Purpose**

The purpose of this work is to provide a generic assessment of the potential occupational dose to transportation workers involved in used fuel transport in Canada. As the location of the APM repository site is unknown at this time, program specific calculations and risk assessments are premature. The intent of this assessment is to provide factual data related to the safety of the transportation system in a transparent manner. This information will provide a basis for decision making, program planning and provide input for design optimization of the components of the transportation system.

### **1.2 Assessment Scope**

This assessment estimates potential individual effective dose (hereafter referred to as 'dose') received by transportation workers resulting from the transportation of used nuclear fuel by road.

Road transportation was determined to be the bounding transport mode for calculating occupational dose to workers. This is due to the fact that workers in the road transport realm are, on average, in closer proximity to the UFTP for longer periods of time than during rail transport. Each transportation shipment is considered to start with the loaded package on the trailer ready to be picked up for transport. The shipment is considered to end when the trailer arrives at the APM repository site receiving bay and is disconnected from the tractor.

Activities including package loading, preparation for shipment, and securing onto the transport trailer which are conducted by workers at a licensed facility are outside of the scope of this assessment.

Occupational dose estimates are limited to normal conditions of transport. Doses due to accident conditions of transport are not addressed in this study. Public doses resulting from potential transport accidents bounded by the conditions defined in the Canadian and International Transport Regulations are assessed in Batters et al. (2012).

Worker doses are calculated for a number of transportation related activities. The calculated doses are compared to the regulatory dose limits defined in the Canadian Nuclear Safety Commission's (CNSC) Radiation Protection Regulations (CNSC, 2000b). Doses are initially compared to the limit for a member of the public to determine whether workers need to be designated as Nuclear Energy Workers (NEWs). If there are instances where dose results exceed the public dose limit, calculated doses are compared against regulatory dose limits for a NEW.

### 1.3 Assessment Basis

This analysis is based upon the following assumptions:

- a) Use of the reference transportation package, the Used Fuel Transportation Package (UFTP). The UFTP was first certified in the 1980's. In 2013, the UFTP was recertified to demonstrate it meets current regulatory requirements.
- b) The UFTP is loaded with 192 CANDU style 37 element used fuel bundles aged, on average, 30 years out-of-reactor. Fuel burnup is discussed under (h) below.

Note: Although the UFTP is certified to transport 10 year old fuel (Stahmer, 2013); the bases of this work assume the fuel to be on average 30 years old to align with the reference repository design (Garisto et. al., 2009).

- c) Only doses associated with road transport are assessed. Occupational dose received by workers during road transport is shown to be higher than occupational dose received during rail transport. See assessment in Appendix D. The transport crew accompanying a road shipment is in closer proximity to the package during transport than for similar transport by rail.
- d) The road conveyance consists of a tractor and trailer loaded with a single UFTP. An annual total of 620 shipments is assumed.
- e) Each used fuel shipment cycle consists of two transport segments: the outbound segment where the UFTP loaded with used fuel is transported from the reactor sites where it is currently stored to the repository site; and the inbound segment where the empty package is returned to the point of origin. Only outbound (loaded) segments are assumed to contribute to occupational dose (an empty UFTP does not emit radiological dose).
- f) Only normal conditions of transport, as defined by the transportation regulations (CNSC, 2000a) and (IAEA, 2000), are considered. Normal conditions of transport are intended to cover situations in which the package is subjected to minor mishaps or incidents ranging in severity, but would continue its journey after having been subjected to these minor mishaps.
- g) Only workers within a 30 m radius of the package are considered. See Appendix A.
- h) The dose rates at various distances from the UFTP are calculated in the generic transportation dose assessment (Batters et al., 2012). Reference fuel with two burnup rates are considered: 220 and 280 MWh/kgU. All used fuel bundles within the UFTP are assumed to have the identical burnup. Used fuel with an average burnup of 220 MWh/kgU is used in annualized dose calculations (assuming peak burnup fuel in annualized calculations would result in higher than realistic calculated dose). Used fuel with a peak burnup of 280 MWh/kgU is used in dose calculations for single occurrence activities to ensure conservative dose estimates. Burnup is described in greater detail in Section 3.1.1 (b).

## 2. RADIATION AND RADIOLOGICAL REGULATORY CONTEXT

### 2.1 Radiation

Radiation emitted by used fuel is in the form of alpha particles, beta particles, neutrons and photons (gamma rays). Alpha and beta particles are stopped by the thick steel walls of the transportation package. Hence, only gamma and neutron radiation levels at various distances from a loaded used fuel transportation package are considered.

Radiation dose, measured in sieverts (Sv), is a measure of the energy absorbed by human tissue and is generally used as an indicator of the potential radiation effect on the human body. Dose rate is the measurement of radiation exposure over a period of time. The dose rate (dose received during a given amount of time) decreases as the distance from the source increases or as protective shielding is added.

### 2.2 Regulatory Context

In Canada, the CNSC sets radiological dose limits to protect the health and safety of persons. This is done by following the recommendations of the International Commission on Radiological Protection (ICRP), which comprises some of the world's leading scientists and other professionals in the field of radiation protection, and by using many of the standards and guides of the International Atomic Energy Agency (IAEA).

Dose limits are established for:

1. a member of the general public
2. a *nuclear energy worker*, defined as a person who is required, in the course of the person's business or occupation in connection with a nuclear substance or nuclear facility, to perform duties in such circumstances that there is a reasonable probability that the person may receive a dose of radiation that is greater than the prescribed limit for the general public (Nuclear Safety and Control Act, S.C. 1997, c.9)

#### 2.2.1 Regulatory Dose Limits

Effective dose limits for the public and nuclear energy workers have been set by the Radiation Protection Regulations (CNSC, 2000b) and are shown in Table 1, below. For the purpose of this assessment, doses to workers are compared (if required) to a dose limit of 20 mSv per year for NEWs (i.e., the regulatory dose limit of 100 mSv averaged over five years for Nuclear Energy Workers).

**Table 1: Regulatory Effective Dose Limits**

Person	Period	Effective Dose
Nuclear energy worker, including a pregnant nuclear energy worker	(a) One-year dosimetry period	50 mSv
	(b) Five-year dosimetry period	100 mSv
Pregnant nuclear energy worker	Balance of the pregnancy	4 mSv
A person who is not a nuclear energy worker	One calendar year	1 mSv

Source: CNSC, 2000b

### 2.2.2 Maximum Radiation Levels

To protect workers and the public, the transportation regulations set maximum radiation levels for transportation packages and the conveyances in which the packages are transported. Additionally, a distinction for shipments requiring *exclusive use* is made. Exclusive use (IAEA, 2000) is the term used to define shipments by a sole consignor with control over the shipment and all initial, intermediate and final loading and unloading operations. According to regulatory requirements, the UFTP is required to be shipped under exclusive use.

Maximum radiation levels for transportation packages and conveyances under exclusive use are defined as follows:

a) Maximum Radiation Levels for Transportation Packages

The radiation level at any point on the external surface of the transportation package shall not exceed 10 mSv/h (CNSC, 2000a).

b) Maximum Radiation Levels for Conveyances

The radiation level at any point on the external surface of a conveyance shall not exceed 2 mSv/h, and shall not exceed 0.1 mSv/h at a distance of 2 m from the surface of the conveyance (CNSC, 2000a).

Maximum radiation levels for the UFTP in its road configuration are illustrated in Figure 1, below.

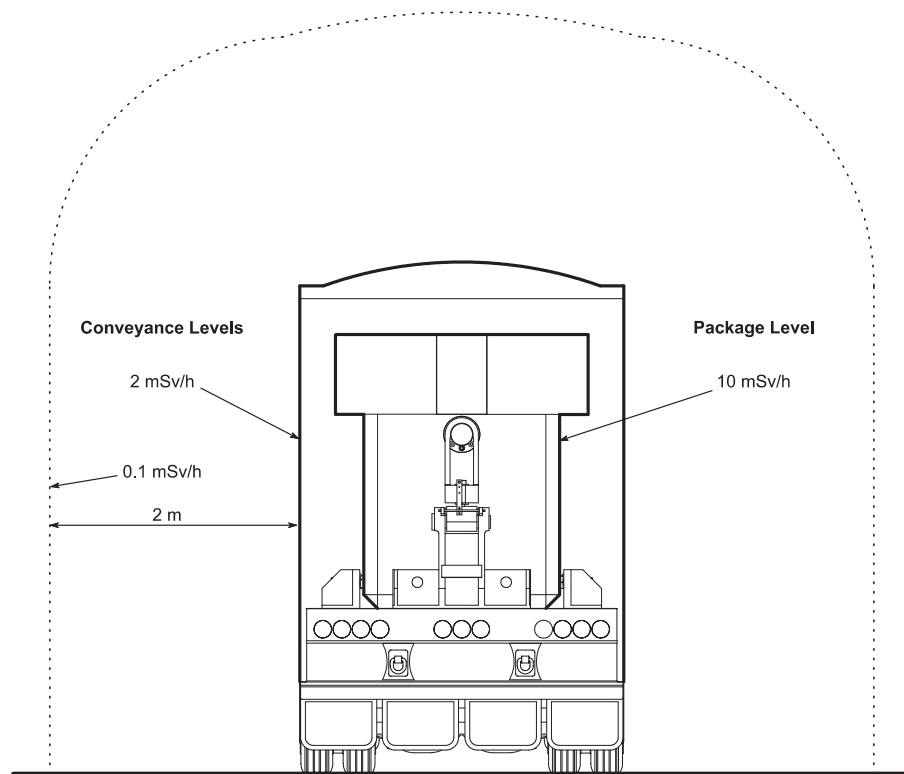

**Figure 1: Maximum Radiation Levels for Packages and Conveyances Transported under Exclusive Use**



### **3. ASSUMPTIONS AND ANALYSIS METHODOLOGY**

#### **3.1 Used Fuel Transportation Package**

The cube shaped UFTP is designed to contain a total of 192 used fuel bundles in two stacked modules. The body and lid of the package are manufactured from Type 304L stainless steel. Both are constructed from single piece forgings or castings. The lid is bolted to the body using 32 bolts. An impact limiter made from redwood encased in a stainless steel shell is bolted to the lid of the package to protect the lid/body seal by reducing impact forces in the event of an accident. The impact limiter also serves as a thermal shield to protect the package seals during a fire. An illustration of the UFTP is provided in Figure 2.

The overall package dimensions are 1881 x 1556 x 1824 mm (excluding impact limiter, protrusions and attachments) and the package and impact limiter weigh approximately 35 tonnes when fully loaded with used fuel. The two long walls are 272 mm thick and the base, lid, and short walls are 267 mm thick. The package can be lifted using trunnions on either side of the body and the lid is lifted via a central flange. The package design incorporates a vent port in the lid and a drain port in the body. Both ports are sealed with a plug and a cover during transport.

The UFTP was designed, tested, manufactured by Ontario Hydro (now Ontario Power Generation) in the mid 1980's. The package design was first certified in the 1980's by the Atomic Energy Control Board (the predecessor of the CNSC). In July 2013, the package design was re-certified to meet current Canadian regulations (CNSC, 2013) and international standards (IAEA, 2000).

##### **3.1.1 Used Fuel Properties**

For the purpose of this assessment, all used fuel bundles inside the UFTP are assumed to be intact (undamaged) standard 37-element bundles. All used fuel bundles are assumed to have uniform decay and discharge burnup:

a) **Used Fuel Decay Time**

All fuel bundles inside the UFTP are assumed to be 30 years out-of-reactor.

b) **Fuel Discharge Burnup**

The radiation emitted by each fuel bundle after discharge from the reactor is dependent on the length of time spent in the reactor and is characterized by the fuel burnup rating. Burnup is a measure of how much fission energy has been produced per unit mass of fuel. Irradiated fuel bundles with higher fuel burnup will emit more radiation.

Bundle-discharge burnups for Pickering A, Pickering B, Bruce A, Bruce B, and Darlington stations have been examined. A burnup of 220 MWh/kgU represents the highest of the average burnups at these plants (Wilk, 2013). A burnup of 280 MWh/kgU represents the 95<sup>th</sup> percentile of all discharged fuel bundles from the Pickering A, Pickering B, and Bruce A stations; and the 99<sup>th</sup> percentile of all discharged bundles from the Darlington and Bruce B stations.

The burnup for used fuel from Gentilly 2 and Point Lepreau stations is generally below 190 MWh/kgU (Wilk, 2013), and hence is bounded by the OPG/Bruce Power values.

For the purposes of this assessment, the average burnup of 220 MWh/kgU is assumed for dose calculations involving multiple annual occurrences (e.g. driver dose). For single occurrences (i.e., a mechanic changing a tire en-route), the more conservative peak burnup of 280 MWh/kgU is used in the dose calculations.

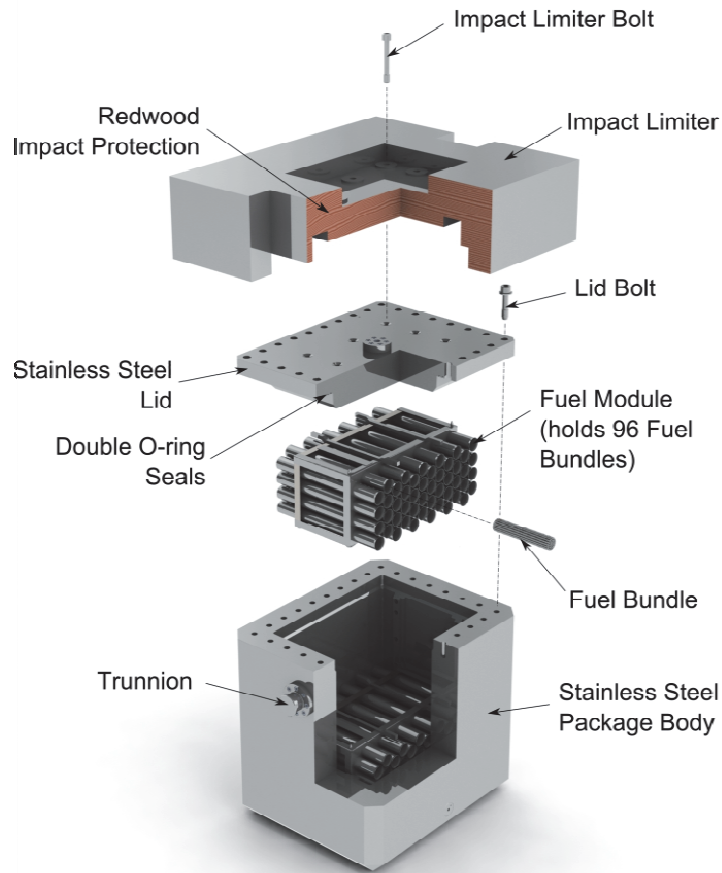

**Figure 2: UFTP Assembly**

### **3.1.2 Weather Cover (Neutron Shield)**

The stainless steel construction of the UFTP provides a very effective shield for gamma radiation; however, it is less effective for shielding neutrons. Although the radiation levels for the UFTP design are below the maximum radiation levels for transportation packages, a neutron shield (doubling as a weather cover and subsequently referred to as such) could be added over top of the package to reduce radiological exposure to the public and workers. Dose rates from the UFTP have been calculated with and without a weather cover in place. The weather cover is assumed to be a 10 cm thick high-density polyethylene cover placed over top of the UFTP during transport operations.

### **3.1.3 Road Transport Configuration**

For transport by road, the assumed configuration consists of a single UFTP on a tractor-trailer unit. The long walls of the UFTP are parallel to the direction of travel and the short walls are in line with the ends of the truck.

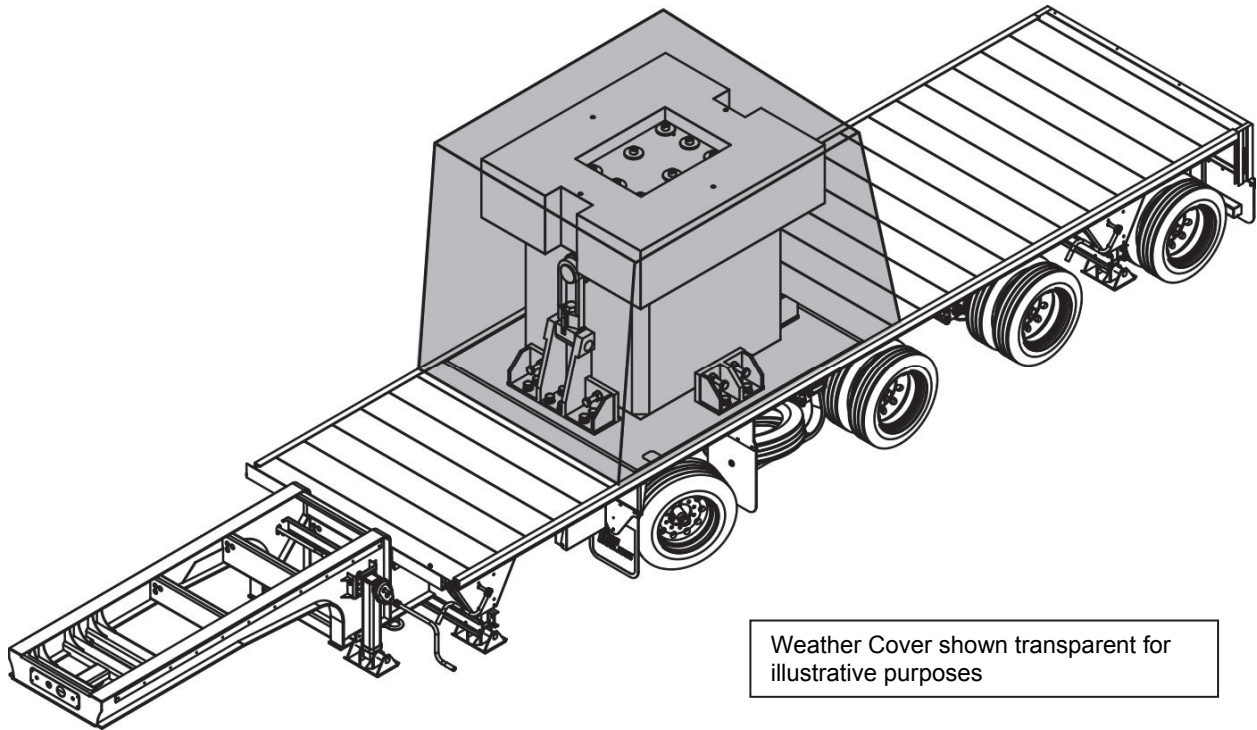

**Figure 3: Typical Road Transport Configuration**

The weight of the fully loaded UFTP is such that only one package can be transported on a tractor-trailer unit at a time and still comply with provincial transportation regulations in Ontario. The semi-trailer configuration consisting of a single UFTP underneath a weather cover (shown transparent for illustrative purposes) is illustrated in Figure 3. The used fuel processing facility at the repository site is designed to handle approximately 120,000 used fuel bundles per year requiring approximately 620 road shipments per year.

### **3.2 UFTP Dose Rates and Maximum Radiation Levels**

Dose rates at various locations and distances from the UFTP were calculated in the Generic Transportation Dose Assessment (Batters et al., 2012) using a representative model of the package and the three-dimensional Monte Carlo N-Particle transport code MCNP5 (LANL, 2003).

Dose rates emitted by a UFTP filled with 192 bundles of used fuel were calculated for an average burnup of 220 MWh/kgU and peak burnup of 280 MWh/kgU. These are compared to the maximum radiation levels described in Section 2.2.2.

- For used fuel with average burnup (220 MWh/kgU), the calculated UFTP dose rate on contact is 0.061 mSv/h. This dose rate is significantly less than the 10 mSv/h level on contact for exclusive use.
- For used fuel with peak burnup (280 MWh/kgU), the calculated UFTP dose rate on contact is 0.10 mSv/h. This dose rate is significantly less than the 10 mSv/h level on contact for exclusive use.

- The conveyance includes a tractor-trailer carrying a single UFTP with a weather cover. Its dose rates would be bounded by the equivalent dose rates calculated for the package. The maximum calculated dose rates from the UFTP on contact (0.1 mSv/h) and at distance of 2 m (0.0033 mSv/h) are below the maximum radiation levels for a conveyance.

**Table 2: Maximum Dose Rates from UFTP (without Weather Cover)**

Distance from Package	Maximum Radiation Level (mSv/h)	UFTP	
		220 MWh/kgU	280 MWh/kgU
Contact	2 (conveyance) 10 (exclusive use package)	0.061 mSv/h	0.10 mSv/h
1 m	-	0.014 mSv/h	0.026 mSv/h
2 m	0.1 (conveyance)	0.0024 mSv/h*	0.0033 mSv/h*

\* Note: Conveyance values at 2 m include a weather cover

### 3.2.1 Maximum Dose Rates

It was found that the maximum dose rates occur at the mid-height of the short side of the package; thus, to be conservative, these dose rates are used in occupational dose calculations.

The dose rates at various distances measured from the UFTP exterior surface where the maximum dose rate is found are tabulated in Table 3 below and graphed in Figure 4 and 5. The external surface of the weather cover is assumed to be approximately 0.4 m from the external surface of the UFTP.

**Table 3: Dose Rates from UFTP**

Distance from Package	220 MWh/kgU burnup			280 MWh/kgU burnup		
	Neutron	Gamma	Total	Neutron	Gamma	Total
Contact	0.0404	0.0208	0.061	0.0852	0.0168	0.10
0.3 m	0.0245	0.0125	0.037	0.0510	0.0153	0.067
1 m	0.00799 <b>0.000445</b>	0.00547	0.014 <b>0.0060</b>	0.0166 <b>0.000445</b>	0.00763	0.024 <b>0.0082</b>
2 m	0.00275 <b>0.00017</b>	0.00224	0.0050 <b>0.0024</b>	0.00575 <b>0.000169</b>	0.00310	0.0089 <b>0.0033</b>
3 m	0.00136 <b>0.000094</b>	0.00114	0.0025 <b>0.0012</b>	0.00283 <b>0.000091</b>	0.00150	0.0043 <b>0.0016</b>
10 m	0.00015 <b>0.000018</b>	0.000116	0.00027 <b>0.00013</b>	0.000314 <b>0.000018</b>	0.000142	0.00046 <b>0.00016</b>
30 m	0.000018 <b>0.000003</b>	0.000012	0.000029 <b>0.000015</b>	0.000037 <b>0.000003</b>	0.000014	0.000051 <b>0.000018</b>

Notes:

- all dose rates are in mSv/h
- dose rates for package only are shown in plain text.
- dose rates for package with weather cover are shown in **bold**.
- gamma dose rates include secondary gamma radiation from neutron interaction with the weather shield.

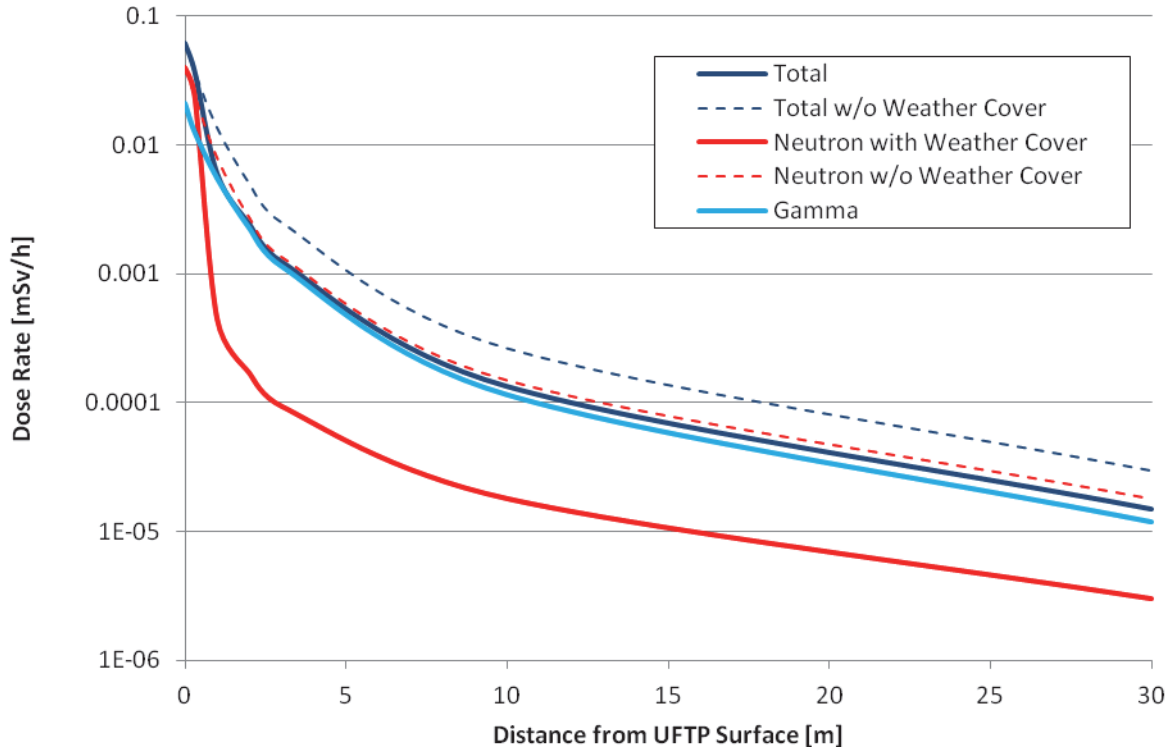
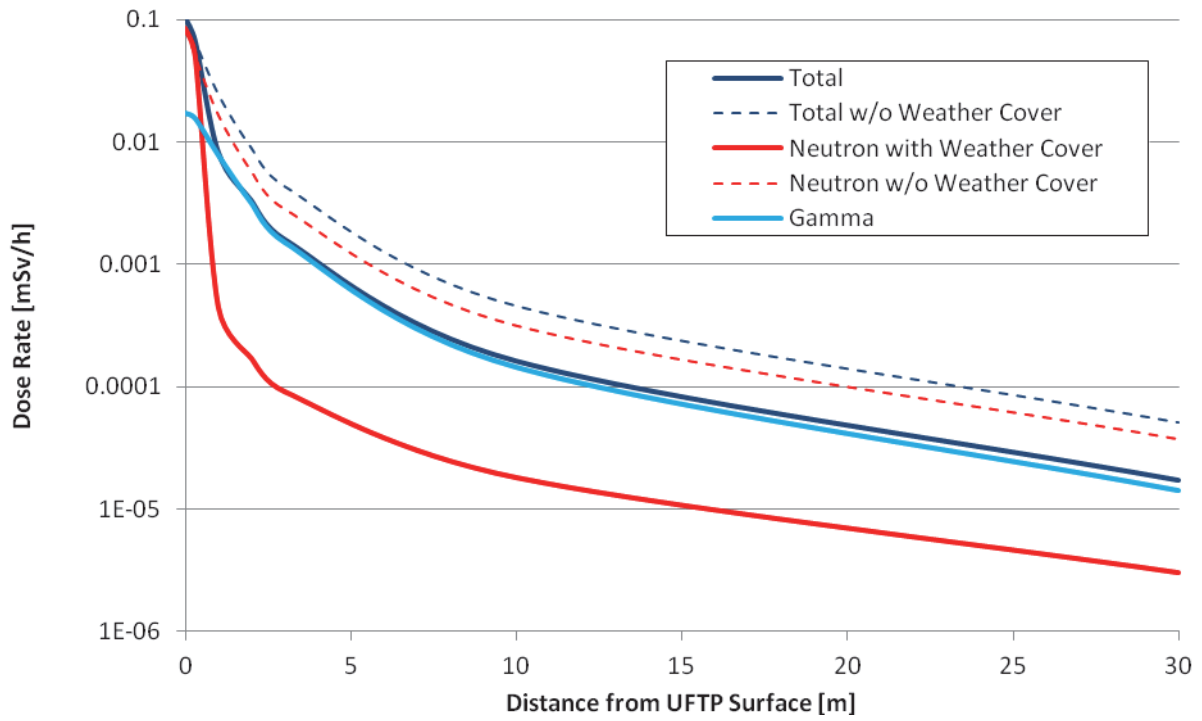

Figure 4: Maximum Dose Rates from UFTP (220 MWh/kgU)



### Figure 5: Maximum Dose Rates from UFTP (280 MWh/kgU)

#### 4. TRANSPORTATION ACTIVITIES

The occupational dose due to used fuel transport is dependent on several factors which include:

- radioactivity of the radiological source (the used fuel)
- shielding present around the source (the transportation package, in this case, the UFTP)
- duration of exposure
- proximity to the radiological source
- frequency of occurrence

The first two factors, radioactivity and shielding, are determined by configuration and package design and therefore do not vary in this study. Thus differences in occupational dose for a given package configuration becomes a function of the remaining three: exposure time, distance and frequency. To calculate occupational dose, activities placing a worker in the vicinity of the package must be determined. For each activity, the activity duration, the worker's distance from the package and the frequency at which a specific activity is carried out must be established. These data are then used to calculate the dose that a worker may receive during that activity. The dose for any given activity is the product of the dose rate at the given distance, the duration of the activity at that distance, and the frequency of occurrence. The total dose the worker will receive is the sum of the doses of all activities the worker engages in. The total dose value is calculated based on a one-year period, to allow comparison with the allowable limits as shown in Table 1.

Activities associated with the transport of used fuel can be divided into three categories:

- pre-shipment activities (preparation for shipment at the interim storage site)
- activities en-route (during used fuel transport)
- activities post receipt at the eventual repository site (inspections, removal of package from trailer, etc.)

The list of activities associated with used fuel transport and the workers conducting each of these activities are itemized in Table 4 below.

**Note:** As stated in Section 1.2, this assessment focuses on activities associated with the physical transport of used nuclear fuel. Activities occurring at the nuclear facilities at the point of origin and destination, such as the loading and unloading of the UFTP to and from the transport vehicle, are conducted by workers within these facilities covered by the facility licences and are not part of this work.

As noted in Section 1.3 (e) above, return shipments do not contain used fuel (do not emit radiation) and thus are not considered to contribute to occupational dose.

Additionally, the scope of occupational dose calculations is limited to workers within a 30 m radius of the package. The basis for this is the calculation that a worker located at 30 m from a fully loaded UFTP during an entire 2000 hour work year would receive a dose of approximately 0.03 mSv or approximately 3% of the regulatory public dose limit or 0.15% of the dose limit for NEWs (see Appendix A).

For each activity and worker listed in Table 4 below, information was obtained from appropriate resources (such as logistics companies, mobile repair services, trucking related associations, etc.) to collect real-world time, distance and frequency scenario data in a Canadian context. These data were analyzed and used to calculate radiological dose for each activity and subsequently for each worker. Data obtained from the sources is included in Appendix B.

**Table 4: Transportation Activities and Associated Workers**

<b>Pre-shipment</b>	<b>En-route</b>	<b>Upon Receipt</b>
<ul style="list-style-type: none"> <li>connecting tractor to trailer</li> <li>vehicle condition inspection</li> <li>documentation check</li> </ul>	<ul style="list-style-type: none"> <li>time in transit (driving)</li> <li>vehicle inspections by driver</li> <li>rest / relief stops</li> <li>refuelling stops</li> <li>en-route transport inspections (weigh scales)</li> <li>breakdown stops – minor en-route repair / tire change</li> </ul>	<ul style="list-style-type: none"> <li>disconnect tractor from trailer</li> <li>post-shipment debrief and documentation filing</li> </ul>
<b>Associated Workers</b>		
<ul style="list-style-type: none"> <li>Driver</li> </ul>	<ul style="list-style-type: none"> <li>Driver</li> <li>Commercial vehicle inspector</li> <li>Commercial weigh scale operator</li> <li>Mechanic / tow truck operator</li> </ul>	<ul style="list-style-type: none"> <li>Driver</li> </ul>

#### 4.1 Driver

As stated in CNSC Regulatory Guide G-208, Transportation Security Plans for Category I, II or III Nuclear Material (CNSC, 2003), the transport crew required for a used nuclear fuel shipment consists of, as a minimum, a driver and an escort. The driver is responsible for the operation of the vehicle and the escort is responsible for on-board communications and surveillance of the shipment. For this study the driver and the escort are assumed to travel in the tractor cab.

During driving and rest stops, the transport crew is assumed to be equidistant from the UFTP. However, non-driving activities performed by the driver, such as connecting and disconnecting the trailer, conducting en-route vehicle condition inspections and refuelling the tractor routinely place the driver in closer proximity to the UFTP than the escort. During these activities, the driver will receive a greater dose than the escort. In reality, some of the driver's activities may be shared by the transport crew.

At this early stage in transport logistics planning, determination of the exact activities of the escort and any work sharing that may occur is premature. However, it is safe to assume that the dose received by the escort will not exceed the dose received by the driver. For calculation purposes, only the dose to the driver is assessed.

Dose received by the driver is a function of pre- and post-shipment activities, number and duration of the stops along the route, and the time spent driving. As the eventual repository site is still unknown, a spectrum of trip lengths is considered. Each of the activities conducted by the driver is described in more detail below. In this assessment, the driver is assumed to be assigned to the same return trip, i.e.: Darlington to Schreiber, over a one year period.

#### 4.1.1 Pre-Driving Activities

Based on the information provided by the carriers interviewed, pre-shipment activities for the driver have been categorized into 3 groups:

##### a) Connecting the tractor and trailer

Connecting the tractor to the trailer includes the following activities:

- checking the 5<sup>th</sup> wheel on the tractor to ensure it is sufficiently lubricated (this activity is conducted prior to arrival).
- backing the tractor under the trailer to engage and lock the kingpin and the 5<sup>th</sup> wheel together
- ensuring that a positive connection has been made
- applying tractor brake
- inspecting the kingpin and 5<sup>th</sup> wheel and ensuring the release arm has moved into the locked position
- attaching the glad-hands (airlines) and electrical connections
- raising the landing gear

This activity typically takes 5 minutes. Additional details on the position of the driver are provided in Appendix B-1 under the activity “Tractor-Trailer Hookup / Unhook”.

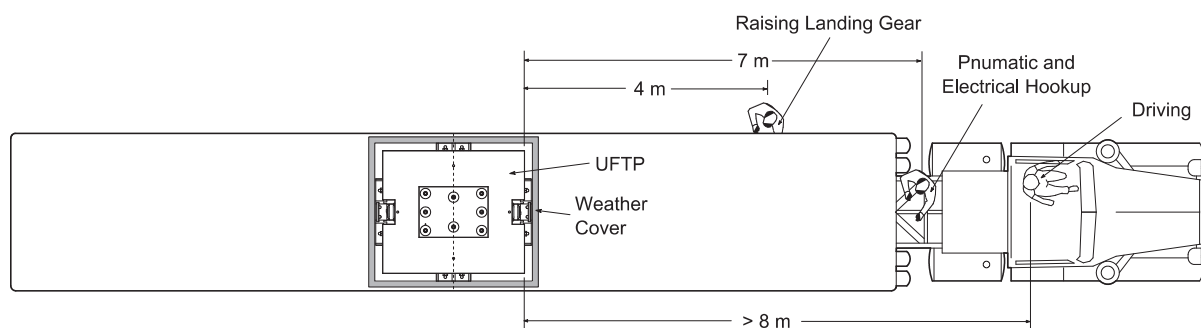

**Figure 6: Driver Connecting Tractor to Trailer**

##### b) Vehicle Condition Inspection

After hookup, the driver conducts a circle check of the vehicle. This check consists of a general condition inspection of the vehicle including: correct load securement, placards and labels, lights operational, etc. The vehicle condition inspection typically takes 10 minutes. Additional details on the position of the driver are provided in Appendix B-6 under the activity “Vehicle Inspections”. Note: any more detailed inspection of the vehicle prior to departure such as a full Commercial Vehicle Safety Alliance (CVSA) Level VI inspection (specific to radioactive materials shipments) is assumed to be conducted by a qualified inspector, and not by the driver.

##### c) Documentation Check

Prior to departure, the driver is briefed by the transportation staff and the driver checks the documentation accompanying the shipment, as required. This activity typically takes 15 minutes and could take place away from the loaded trailer. For calculation purposes, the driver is assumed to be in the tractor cab during this time (to maximize dose to the driver).



## 4.1.2 En-route Activities

### 4.1.2.1 Driving

Driving time must be established to estimate radiological dose to the driver. The time required to complete one shipment cycle (a round trip shipment – UFTP loaded with used fuel from the interim storage site to the repository and an empty UFTP on the return trip) is the sum of times for all activities performed by the driver over the course of the trip.

#### a) Transport Crew Location

The NWMO UFTP Mobile Display tractor-trailer configuration is assumed to be typical of the configuration that will be used once transport operations begin. In this configuration, the distance between the package and leading edge of the trailer is 6.6 m as shown in Figure 7, below. Tractors with sleeper units behind the driver are typically longer than those without, placing drivers at a further distance from the UFTP. In the existing UFTP mobile exhibit tractor-trailer unit, the distance between the front wall of the UFTP and the rear wall of the tractor sleeper berth is approximately 8 m. Conservatively, for calculation purposes, the transport crew is assumed to be located at 8 m from the UFTP. No credit is given for any shielding provided by the sleeper or tractor walls. Additional details on the position of the driver are provided in Appendix B-5 under the activity “En-route Transport”.

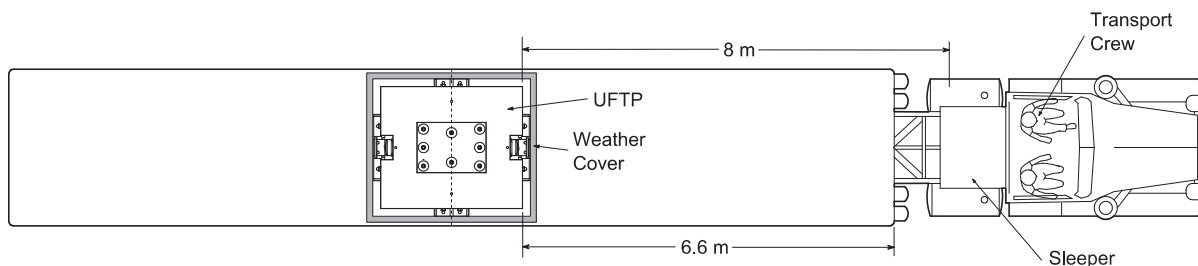

**Figure 7: Transport Crew in Tractor Cab during Driving**

#### b) Trip Length

As the repository site location is unknown, various trip lengths are considered. Eleven communities are currently in the site selection program (one in Saskatchewan, one in Ontario west of Thunder Bay, four between Thunder Bay and Sault Ste. Marie, two near Elliot Lake, and three in southwestern Ontario). To characterize transport between the interim storage locations and these communities, six representative trip lengths ranging from 50 km to 2900 km are considered. These trip lengths, detailed further in Section 4.1.2.2, have been selected to represent typical distances from the existing interim storage sites to potential repository sites. For calculation purposes, five of the trips assume the representative point of origin to be the Darlington nuclear facility, as transport from Darlington maximizes travel through densely populated areas. The 6th trip assumes the trip origin to be the Bruce Nuclear facility and the destination a representative site in southwestern Ontario approximately 50 km away.

#### c) Population Density

Transport speed along a road or regional highway is dependent to a degree on the population density of the area through which the road travels. For example, rural highway speed limits are often reduced in areas where the highway passes through a town. To account for this, population centres along representative trips are examined.

Statistics Canada defines, “A population centre as area with a population of at least 1,000 and a density of 400 or more people per square kilometre. All areas outside population centres will continue to be defined as rural area.” (Statistics Canada, 2011). However, these two divisions are too broad for the purposes of this investigation.

To account for the numerous small towns with populations less than 1000 and posted speed limits less than highway speed, population densities in this assessment have been broken into three ranges: urban, suburban and rural. These densities were selected to allow identification of areas of reduced speed limits along roadways (see Figure 8). The population densities are classified as:

- Urban: more than 650 persons per km<sup>2</sup>
- Suburban: 50 to 650 persons per km<sup>2</sup>; and
- Rural: less than 50 persons per km<sup>2</sup>.

This division is similar to the population density classifications used in the radiological assessment code RADTRAN (Weiner et al., 2009). Note that the suburban range (50 to 650 persons per km<sup>2</sup>) straddles Statistics Canada’s value of 400 persons per km<sup>2</sup> for the urban/suburban boundary.

Population densities in Ontario were obtained using Statistics Canada data from the 2011 census (Statistics Canada, 2011). A map showing the population densities in Ontario is provided in Figure 8.

Each trip is broken down into segments based on the population density zone it passes through. The distance of each segment is calculated and an associated transport speed is assigned. For each trip, the total distance through each population density zone is determined.

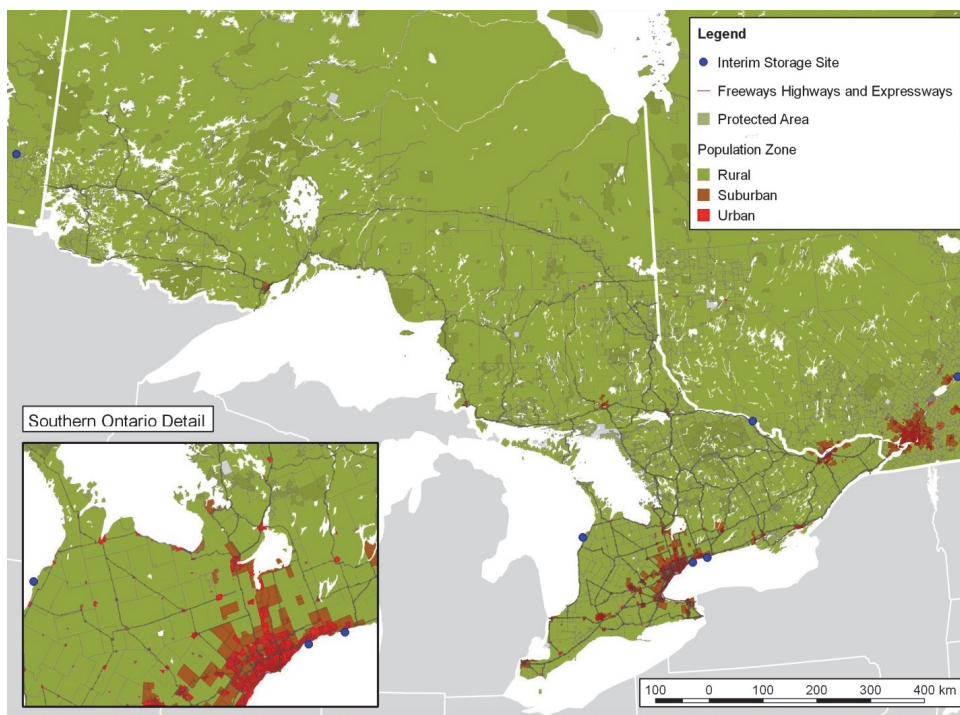

**Figure 8: Sample Population Density Zone Map**

d) Transport Speed in Population Density Zones

Typical posted transport speed limits through population density zones are provided in Table 5 below. Although use of highways is assumed (controlled access highways through large population areas), average transport speeds are frequently lower than the posted speed limits due to traffic congestion. For example, the average speed of commuting through Toronto is 42 km/h (Metrolinx, 2008), hence this speed is assumed for all urban segments. A speed of 45 km/h is assumed for suburban segments and a speed of 70 km/h for rural segments. These assumptions fall within the range of average speeds published by the Transportation Association of Canada (TAC) (Kingston, 2011)

**Table 5: Transport Speed Limits in Population Density Zones**

<b>Population Density</b>	<b>Typical Posted Speed Limit</b>	<b>Speed Assumed in Calculations</b>
Urban ( $\geq 650$ persons per $\text{km}^2$ )	100 km/h (controlled access highway) 50 km/h (city street)	42 km/h*
Suburban ( $< 650$ persons per $\text{km}^2$ and $\geq 50$ persons per $\text{km}^2$ )	80 to 100 km/h (highway)	45 km/h**
Rural ( $< 50$ persons per $\text{km}^2$ )	80 to 90 km/h (highway)	70 km/h**

\* Reference: Metrolinx, 2008

\*\* Reference: Kingston, 2011

e) Transport Distance and Time

For each trip, distances through the three population density zones: urban, suburban and rural, are calculated (see Table 6). The communities presented in this table are selected solely to provide a range of possible transport distances. Using the transport speeds in Table 5, the travel time in each population density zone is calculated and summed to obtain a total travel time. Note that travel time does not include stops along the route. Stops during driving are addressed in the next section.

4.1.2.2 Stops during Driving

Carriers, such as Caravan Logistics and Ontario Power Generation, were contacted to provide information on typical activities of the driver during routine trips. Frequencies of the activities were also provided. Stops are divided into three categories: rest and relief, en-route vehicle condition inspections, and refuelling. Each is described in more detail in Sections (a) to (c) below.

**Table 6: Distances and Travel Times through Population Density Zones**

Representative Trip	Distance	Distance and Travel Time in Zone			Total Travel Time
		Urban	Suburban	Rural	
Bruce to South Bruce	50 km	0 km	3 km	47 km	00:44 h
		00:00 h	00:04 h	00:40 h	
Darlington to South Bruce	250 km	86 km	47 km	117 km	04:45 h
		02:02 h	01:03 h	01:40 h	
Darlington to Elliot Lake	600 km	82 km	64 km	454 km	09:51 h
		01:57 h	01:25 h	06:29 h	
Darlington to Schreiber	1200 km	89 km	83 km	1028 km	18:38 h
		02:07 h	01:50 h	14:41 h	
Darlington to Ignace	1700 km	99 km	98 km	1503 km	26:00 h
		02:21 h	02:11 h	21:28 h	
Darlington to Creighton	2900 km	102 km	139 km	2659 km	43:30 h
		02:26 h	03:05 h	37:59 h	

a) Rest and Relief Stops

Rest and relief stops are required during any lengthy journey. Based on information provided by commercial trucking firms, rest and relief stops are typically 30 minutes in length and are made approximately every 400 km or 4 hours of driving time. All trips greater than 300 km in length are assumed to have at least one stop for rest or relief (Note: it is assumed that rest stops are not taken during 50 km and 250 km shipments). As traffic congestion and unplanned traffic slowdowns or stoppages cannot be predicted, for dose calculation purposes, rest and relief stops are based on travel distance and not driving time.

Although it is expected that each member of the transport crew will leave the tractor cab over the course of the stop, for dose calculation purposes, the driver is assumed to remain in the tractor cab during each rest stop for its entirety (to maximize dose to the driver). Additional details on the position of the driver are provided in Appendix B-3 under the activity “Rest / Relief Stop”.

b) En-route Vehicle Condition Inspections

Regulations require that the condition of a commercial vehicle is monitored by the driver during transport. This requirement is met through en-route vehicle condition inspections. These inspections carried out by the driver are typically conducted every 200 km and are similar to the pre-shipment vehicle condition inspection discussed in Section 4.1.2 (b) (Note: it is assumed that there are no en-route vehicle inspection stops for trips less than 300 km in length). Additional details on the position of the driver are provided in Appendix B-5 under the activity “Vehicle Inspections”. For dose calculation purposes, the driver is assumed to conduct all vehicle condition inspections, placing him or her in close proximity to the package more frequently than any other transport crew member.

c) Refuelling Stops

Refuelling stops of a tractor-trailer loaded with used nuclear fuel should be kept to a minimum. It is assumed that the fuel tanks on the tractor are full at the point of origin. The range of a

tractor-trailer is approximately 1400 km, thus only trips greater than 1400 km in length will require refuelling. The time to refuel takes approximately 20 minutes.

Refuelling is assumed to take place at a commercial cardlock station such as the one shown in Figure 9. Cardlock stations can support the refuelling of multiple vehicles at the same time. The assumed configuration of the cardlock station along with the time and distance assumptions used in the dose calculations is presented in Appendix B-4. For calculation purposes, the driver is assumed to be located 6 m from the UFTP during refuelling.



**Figure 9: Commercial Cardlock Station on Highway 17**

#### **4.1.3 Post-Driving Activities**

Upon arrival at the destination, the driver disconnects the tractor from the trailer. This is essentially the reverse of the activities listed in Section 4.1.1 (a) and requires the same amount of time (5 minutes). Last, the driver prepares documentation for filing into a records management system and is debriefed by the transportation manager. This activity typically takes 15 minutes and would typically take place away from the trailer. For calculation purposes, this is assumed to take place at 8 m from the UFTP (to maximize dose to the driver).

#### **4.1.4 Driver Activity Summary**

##### **a) Pre- and Post-Driving Activity Summary**

The calculation of total driving time includes pre- and post-shipment activities. Typical activities for the driver detailed in Appendix B are summarized in Table 7 below. Typically, pre-shipment activities performed by the driver require 30 minutes and post-shipment activities require 20 minutes.

**Table 7: Pre- and Post-Shipment Activities**

<b>Activity</b>	<b>Duration</b>	<b>Performed by</b>
Tractor Hookup to Trailer	5 min	Driver – Pre-Shipment
Vehicle Condition Inspection	10 min	Driver – Pre-Shipment
Documentation Preparation and Check	15 min	Driver – Pre-Shipment
Unhook Tractor from Trailer	5 min	Driver – Post-Shipment
Documentation Submission and Debrief	15 min	Driver – Post-Shipment

b) En-route Activity Summary

Parameters used to determine the number of and total time for stops along the trip are summarized in Table 8 below.

**Table 8: Stop Durations and Frequencies**

<b>Stop Type</b>	<b>Duration</b>	<b>Frequency</b>
Rest / Relief	30 min	Every 400 km or 4 hours All trips over 300 km have at least one rest stop
Vehicle Condition Inspection	10 min	Every 200 km for trips greater than 300 km
Refuelling	20 min	Every 1400 km

**4.1.5 Time per Shipment and Maximum Annual Shipments per Driver**

The total time per shipment includes the times for pre- and post-shipment activities, all stops and time in transit. Shipment times for each of the 6 representative trips are summarized in Table 9, below.

Used fuel delivery from the reactor sites where it is currently stored to the repository site will require approximately 620 UFTP shipments per year. Using the representative trip lengths presented in Table 6, a given driver is only able to perform a fraction of this total. The maximum number of annual shipments for a given driver can be estimated by dividing the number of available work hours by the total time for a return shipment (a 2000 hour work year is assumed: 40 working hours per week, 50 weeks per year) and is presented in Table 9. In the case of the 50 km trip (Bruce site to repository site in Southwestern Ontario), the maximum number of annual trips is calculated to be 636. However, current transport logistics estimates (Stahmer, 2009) indicate that the maximum number of annual shipments originating from the Bruce site is 295. In this case, the number of annual shipments for the driver has been reduced from the calculated number (636) to the number provided in current transport logistics estimates (295).

Due to hours of service requirements, trips over 600 km in length may require multiple drivers or overnight stops. Addressing of these logistics decisions is premature and out of scope for this analysis; however, trip length has minimal impact on annualized driver dose. See Section 6.1.1 for discussion on data sensitivity.

**Table 9: Maximum Annual Shipments per Driver**

Activity	Trip Length					
	50 km	250 km	600 km	1200 km*	1700 km*	2900 km*
Pre-Shipment	00:30 h	00:30 h	00:30 h	00:30 h	00:30 h	00:30 h
Rest / Relief Stops	00:00 h (0 stops)	00:30 h (1 stop)	00:30 h (1 stop)	01:30 h (3 stops)	02:00 h (4 stops)	03:30 h (7 stops)
Vehicle Condition Inspection Stops	00:00 h (0 stops)	00:00 h (0 stops)	00:20 h (2 stops)	00:50 h (5 stops)	01:20 h (8 stops)	02:20 h (14 stops)
Refuelling Stops	00:00 h (0 stops)	00:00 h (0 stops)	00:00 h (0 stops)	00:00 h (0 stops)	00:20 h (1 stop)	00:40 h (2 stops)
Driving Time	00:44 h	04:45 h	09:51 h	18:38 h	26:00 h	43:30 h
Post-Shipment	00:20 h	00:20 h	00:20 h	00:20 h	00:20 h	00:20 h
<b>Total Time per Shipment (one way)</b>	<b>01:34 h</b>	<b>06:05 h</b>	<b>11:31 h</b>	<b>21:48 h</b>	<b>30:30 h</b>	<b>50:50 h</b>
<b>Maximum Annual Shipments</b>	<b>295**</b>	<b>164</b>	<b>86</b>	<b>45</b>	<b>32</b>	<b>19</b>

\* Multiple drivers or overnight stops will be required to meet Hours of Service requirements.

\*\* The number of annual shipments originating from the Bruce site. See NWMO TR-2009-21.

## 4.2 Provincial Commercial Vehicle Inspector

Provincial commercial vehicle inspectors ensure that commercial vehicles are in compliance with acts, regulations and safety standards. Their role is to visually inspect vehicles and load securing systems to look for defects. They also review documentation, inspect driver licenses and log books, examine commercial vehicle licenses, insurance documents, and permits for compliance with applicable acts and regulations.

Through the Commercial Vehicle Safety Alliance (CVSA), commercial vehicle inspections have been harmonized between provinces. There are several levels of inspection ranging from a comprehensive (Level I) inspection that evaluates both the driver and vehicle, to ones with a more specific area of focus, such as for hazardous or radioactive materials (Level VI). Inspections and affixing of CVSA decals must be performed by certified inspectors. The term "certified" means the government employee performing inspections and/or affixing CVSA decals must have successfully completed a training program approved by the CVSA.

Vehicle inspections typically follow a similar pattern termed the circle check (see Figure 10). Inspection durations will vary depending on the comprehensiveness of the inspection, but the inspection consists of an inspector walking around the conveyance, and at times, going underneath and on to the vehicle deck to inspect the various components and features (e.g. brakes and tie-downs).

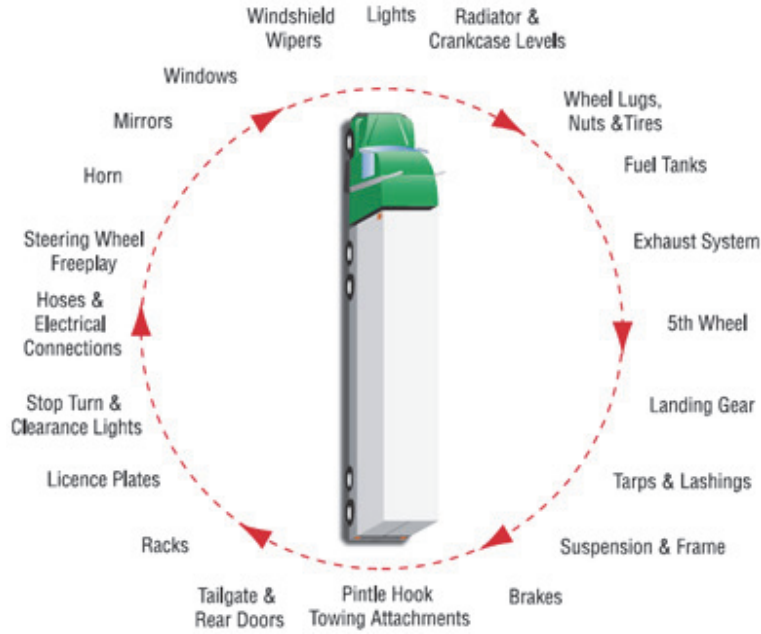

Source: Ontario Ministry of Transportation (MTO)

**Figure 10: Commercial Vehicle Circle Check**

Dose received by the inspector during the inspection will vary depending on the level of inspection being conducted. Data provided by the Ontario Ministry of Transportation (MTO) indicates that approximately 110,000 commercial vehicle inspections are conducted by government inspectors annually. Details on the proximity and duration of the inspector to the vehicle for the different inspection levels are provided in Appendix B-6 under the activity “Vehicle Inspections”.

#### **4.3 Commercial Weigh Scale Operator**

Regulations require that commercial vehicles be weighed periodically. Weighing typically takes place at either government or commercial weigh stations along highways, but may also be performed en-route by ministry inspectors using portable scales.

During the weighing, a weigh scale operator may be in proximity of a loaded UFTP. With information provided by the MTO, placement of weigh scale operators was established for both stationary and portable scales. Dose received by the weigh scale operator will vary depending on the type of scale being used to weigh the vehicle. A typical stationary weigh scale configuration is shown in Figure 11 below. Additional details for the different scale configurations are provided in Appendices B-7 and B-8 under the activities “Weighing at Weigh Station” and “Weighing with Portable Weigh Scale”.



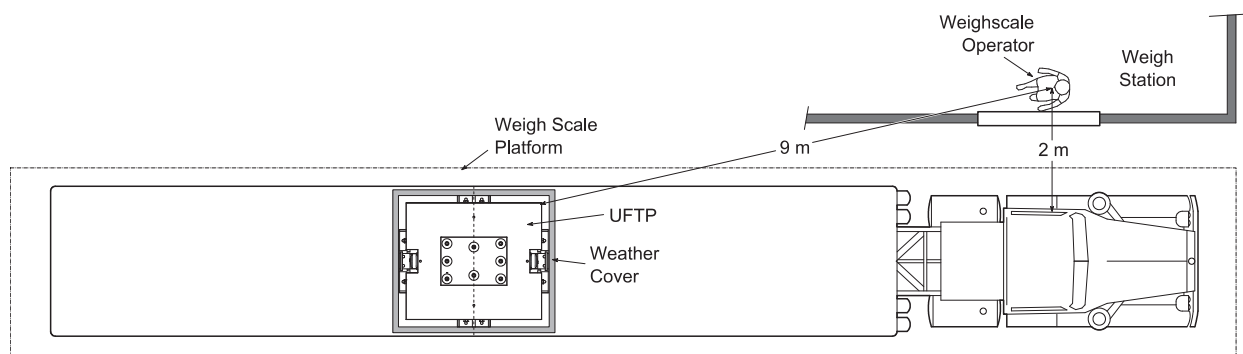

**Figure 11: UFTP Shipment in Stationary Weigh Scale**

#### **4.4 Mechanic – Mobile Repair Service Operator**

UFTP transportation equipment will be maintained to the highest standards and will be inspected prior to departure as well as en-route and upon arrival at the destination. However, breakdowns of equipment may occur. Mobile repair services will be at times required to fix flat tires or make minor repairs to the tractor-trailer while it is en-route. Depending on the nature of the breakdown, the repair work may place a mechanic or tow truck operator close to a loaded UFTP.

Mobile breakdown services were contacted and typical repairs that may be required during transit were established. Replacement of the inner tire of a dual tire group and the repair of a maxipot brake chamber were considered to be typical roadside repairs. In either case, the repair time and distance from the UFTP is assumed to be similar. For the dose calculations, the mechanic is assumed to be located at a distance of 0.4 m away from the UFTP during the duration of the repair. For a given mechanic, this scenario is assumed to be a singular event. Additional details are provided in Appendix B-9 under the activity "Minor Breakdown or Tire Repair".

### **5. ILLUSTRATIVE OCCUPATIONAL DOSE**

Calculation of individual dose to a worker for a given scenario is the product of the dose rate at the distance defined in the scenario, the exposure time and frequency. The relative distance between the worker and UFTP is assumed to be fixed during this time.

For example, from Table 3, the dose rate at 10 m from the package and weather shield is 0.00013 mSv/h. This means an individual standing 10 m away from the long side of the package for one hour would receive a dose of 0.00013 mSv. If the individual is present at that location for 15 minutes, they would receive a dose of 0.000033 mSv, or one quarter of the hourly dose. Likewise, an individual present at that location for 3 hours would receive a dose of 0.00039 mSv, or three times the hourly dose.

Exposure frequency must also be considered to calculate annual dose. From the example in the paragraph above, an individual located 10 m away from the long side of the package for 15 minutes receives a dose of 0.000033 mSv. Assuming the individual experiences this scenario 5 times during the span of a year, the individual then receives 5 times the dose received in the 15 minute exposure, or 0.00016 mSv per year.

As mentioned in Section 3.1.2, the weather cover provides additional shielding of neutron radiation. The weather cover is an integral part of the transportation system and the UFTP will be covered during all shipments.

There are instances where the relative motion between the worker and the UFTP are not fixed, such as a UFTP shipment passing a weigh scale operator. In cases such as this, calculation of dose to the worker differs somewhat from the calculations described above. Here the worker is assumed to be stationary at a given distance from the passing UFTP shipment. As the vehicle approaches, the dose rate the individual is exposed to will increase till it reaches a maximum when the transportation package(s) is (are) closest to the individual. The dose rate then decreases as the vehicle continues on its route. The total dose received is dependent on vehicle speed; the faster the vehicle speed, the lower the dose because of the reduced exposure time. This methodology is discussed in more detail in Appendix C.

### 5.1 Driver

Driver dose is the sum of doses received during pre-shipment, en-route and post-shipment activities. These activities are dependent on many factors including traffic conditions, road conditions, vehicle speed, trip length, population density, en-route condition inspection and rest stop frequencies, etc.

**Table 10: Driver Dose Summary**

<b>Shipment Length</b>	<b>50 km</b>	<b>250 km</b>	<b>600 km</b>	<b>1200 km</b>	<b>1700 km</b>	<b>2900 km</b>
<b>Per-shipment Dose by Activity (all doses in mSv)</b>						
Pre-shipment	0.00066	0.00066	0.00066	0.00066	0.00066	0.00066
Driving	0.00015	0.00095	0.0020	0.0037	0.0052	0.0087
Rest Stops	0.00	0.00010	0.00010	0.00030	0.00040	0.00070
Condition Inspections	0.00	0.00	0.0012	0.0029	0.0046	0.0081
Refuelling	0.00	0.00	0.00	0.00	0.00012	0.00023
Post-Shipment	0.000088	0.000088	0.000088	0.000088	0.000088	0.000088
<b>Per-Shipment Dose</b>	<b>0.0009</b>	<b>0.0018</b>	<b>0.0040</b>	<b>0.0077</b>	<b>0.011</b>	<b>0.018</b>
<b>Annual Dose by Activity (all doses in mSv)</b>						
Pre-shipment	0.20	0.11	0.057	0.030	0.021	0.013
Driving	0.044	0.16	0.17	0.17	0.17	0.17
Rest Stops	0.00	0.016	0.009	0.014	0.013	0.013
Condition Inspections	0.00	0.00	0.099	0.13	0.15	0.15
Refuelling	0.00	0.00	0.00	0.00	0.004	0.004
Post-Shipment	0.026	0.014	0.008	0.004	0.003	0.002
<b>Annual Dose</b>	<b>0.27</b>	<b>0.30</b>	<b>0.34</b>	<b>0.34</b>	<b>0.35</b>	<b>0.35</b>

Note: All doses rounded to 2 significant digits.

Each driver activity was identified and assessed individually to determine driver location and time. This data was then used to calculate the maximum number of shipments a driver could make in a given year. Once this was established, per-shipment and annual dose to the driver was calculated. The results for the 6 different trip lengths discussed in Section 4.1.2.1 are summarised in Table 10 above. Detailed calculations and assumptions for each activity are presented in Appendix B-1 through B-4 and are summarized in Appendix B-5.

## 5.2 Commercial Vehicle Inspector

Vehicle inspection standards are established by the CVSA and compliance inspections are conducted, in Ontario, by the Ministry of Transportation (MTO). Inspections typically consist of a circle check of the vehicle placing the inspector at various distances from the package during the course of the inspection. Inspections to the various CVSA levels range in completion time from approximately a half-hour for a CVSA Level II inspection to one-and-a-half hours for a CVSA Level VI inspection.

To address the issue of varying distance from the package, the area around the vehicle was divided into 1 m<sup>2</sup> parcels and the inspector was assumed to be in each of the 46 parcels an equivalent amount of time. This methodology is described in further detail in Appendix B-6 and was applied to all vehicle inspections, both CVSA and en-route vehicle condition inspections performed by the driver.

Data provided by MTO indicates that government inspectors inspect approximately 110,000 commercial vehicles per year across all inspection levels. This is only a small fraction of the number of shipments made. For dose calculation purposes, the MTO agreed that inspection of 5% (or 31 shipments per year) of all UFTP shipments was reasonable. For additional conservatism, all of these inspections are assumed to be conducted by the same inspector.

A summary of the dose calculation results for the CVSA inspections is in provided in Table 11, below.

**Table 11: Commercial Vehicle Inspector Dose**

Inspection Level	Dose per Inspection [mSv]	Number of Inspections by given Inspector	Annual Dose [mSv]
CVSA Level I	0.0035	31	0.11
CVSA Level II	0.0017	31	0.054
CVSA Level VI	0.0052	31	0.16

Note: All doses rounded to 2 significant digits.

## 5.3 Commercial Weigh Scale Operator

Commercial vehicle scales at weigh stations vary in size. Some have scales that can only weigh axle groupings while others can weigh the entire vehicle at once. Depending on the weigh station, the time required to weigh a vehicle will vary. Additionally, Ministry inspectors have portable scales that can be used to weigh a vehicle along a roadway (see Figure 12). These variances were considered in calculating dose to a weigh scale operator.

For operators at stationary scales, the methodology applied in dose calculations was similar. The operator was assumed to be in a fixed position during the weighing activity. For a large

scale, only one fixed position (operator near tractor cab) was considered. For small scales, a second fixed position placing the operator in closer proximity with the rear axle grouping was added. In both cases, dose received during vehicle approach and departure was included (see Appendix B-7).

Weighing a vehicle using portable scales requires two scale units, one for each side of the vehicle. One axle is weighed at a time. The scales are placed on the ground in front of the wheels and the vehicle is driven forward onto the scales. The axle weight is the sum of the weights of each scale. Weighing of a tractor-trailer in this manner typically takes 15 minutes. Equal time is assumed to be required at each axle location. The dose to the inspector is calculated to be the sum of the dose received at each axle location during the total weighing activity (see Appendix B-8).



**Figure 12: MTO Weigh Station and MTO Officer using a Portable Scale**

Based on information provided by the Ontario Ministry of Transportation (MTO), any given operator was assumed to be present for 5% of all 620 annual shipments (31 shipments). The dose received by weigh scale operators is summarized in Table 12 below.

**Table 12: Weigh Scale Operator Dose**

Scale Type	Operator Dose per Weighing [mSv]	Number of Inspections by given Inspector	Annual Dose [mSv]
Stationary – Large Platform	0.000084	31	0.00026
Stationary – Small Platform	0.000089	31	0.0028
Portable	0.00040	31	0.012

Note: All doses rounded to 2 significant digits.

#### **5.4 Mechanic – Mobile Repair Service**

Commercial trucking operators and mobile repair service providers were contacted to identify the types of breakdowns that could typically be expected to be repaired en-route: Breakdowns in two categories were identified: tire replacement and brake chamber replacement. For dose calculations, the mechanic is assumed to be positioned in close proximity (approximately 0.4 m, alongside the weather cover) of the UFTP. Roadside repairs such as these typically take between one half to 1 hour to complete. The dose received by the mechanic during the repair is calculated to be 0.017 mSv (see Appendix B-9).

### **6. DISCUSSION OF RESULTS**

#### **6.1 Driver**

Radiological dose received by the driver for a given shipment is largely a function of shipment length. The dose received by a driver varies from 0.0009 mSv for a 50 km shipment to a dose of 0.018 mSv for a 2900 km shipment. However, as a given driver on a short route will make many more shipments during a given year than a driver on a long route, the annualized doses received by a driver end up varying very little. As presented in Table 10, the lowest dose is 0.27 mSv per year for a driver on the 50 km route while the dose for a driver on the 2900 km route is only 0.35 mSv per year.

Occupational doses to workers under normal transport conditions were estimated to be below the dose limit for a member of the public (i.e., 1 mSv per year); and, by extension well below that of 20 mSv per year for NEWs (i.e., the regulatory dose limit of 100 mSv averaged over five years for Nuclear Energy Workers).

Dose rates and resulting occupational doses received by workers have been calculated and are not based on measured values. Dose monitoring of occupational activities for drivers and security escorts will be established when the radiation protection program is developed, prior to the operational start up of the used fuel transportation program.

##### **6.1.1 Data Sensitivity**

As mentioned in Section 5.1, driver dose is dependent on many factors. To determine the sensitivity of the annualized dose to the various inputs, calculations were repeated with varying inputs. For example, the calculated dose received by a driver in the base assumption ranges from 0.27 mSv per year to 0.35 mSv per year. This assumes average transport speeds of 42 km/h for urban areas, 45 km/h for suburban areas and 70 km/h for rural areas. See Base Assumption in Table 13 below.

Recalculating driver dose using typical posted speed limits of 100 km/h for urban areas, 50 km/h for suburban areas and 80 km/h for rural areas only marginally affects the annual driver dose. For this data, the dose range is 0.25 to 0.39 mSv per year. See the column "Posted Speed" in Table 13 below.

Using typical posted speed limits of 100 km/h for urban areas, 50 km/h for suburban areas and 80 km/h for rural areas in Southern Ontario (trips of 50 and 250 km in length) and 90 km/h for rural areas in Northern Ontario and extending the rest stop length from 30 to 45 minutes in length, the dose range is 0.26 to 0.38 mSv per year. See the last column in Table 13 below.

**Table 13: Data Sensitivity to Transport Speed and Rest Stop Length**

	Base Assumption	Posted Speed	Posted Speed – Longer Rest Stop
Transport Speed			
Urban	42 km/h	100 km/h	100 km/h
Suburban	45 km/h	50 km/h	50 km/h
Rural	70 km/h	80 km/h	80 or 90 km/h
Rest Stop Length	30 min	30 min	45 min
Annual Driver Dose	0.27 mSv – 0.35 mSv	0.25 mSv – 0.39 mSv	0.26 mSv – 0.38 mSv

This consistency in driver dose can be readily explained. Varying the transport speed, rest stop and en-route inspection frequencies, or pre- and post-shipment activities all end up affecting the number of shipments per year. A faster shipment cycle means more shipments by the driver; a slower shipment cycle means fewer shipments. However since the length of the work year and hours of service remain fixed, the impact of dose to the driver is minimal, because the time spent by the driver in front of the package remains similar.

Conservatively, the transport crew was assumed to remain in the tractor cab during the documentation check (both pre- and post-shipment) and during all the rest stops. In reality, the crew is not restricted to remain in the cab during these activities. For all transport distances, occupational dose is dominated by dose received while performing activities other than documentation checks and rest stops. The annual dose range for the driver was unaffected when the doses were recalculated assuming virtually zero dose during these activities.

## 6.2 Commercial Vehicle Inspector

The potential dose to a commercial vehicle inspector varies from 0.054 mSv for an inspector inspecting 31 shipments annually to CVSA Level II standards to 0.16 mSv for an inspector inspecting 31 shipments annually to CVSA Level VI standards.

Although dose to the inspector for a singular inspection is low (two CVSA Level VI inspections are roughly equivalent to a dental x-ray (typically 0.01 mSv (Mettler, 2008)), awareness of potential dose uptake and caution are advisable for all detailed inspections. (According to CVSA, most employers require dosimeters to be worn as part of the personal protective equipment to be worn by inspectors conducting Level VI inspections. All Level VI qualified inspectors interviewed were Haz Mat qualified. The transport crew will be equipped with dose monitoring equipment and will be trained to instruct the inspector to minimize exposure by conducting work (when possible) at a greater distance from a loaded package.

In the unlikely event that more than 5% of shipments are inspected by the same inspector during a given year, the possibility exists that the dose received by that inspector may exceed the public dose limit of the dose of 1 mSv per year. The maximum number of inspections that a given inspector can perform without exceeding this limit is presented in Table 14, below.

**Table 14: Maximum Inspections for a Given Inspector**

Inspection Level	Maximum inspections per Inspector
Level I	289
Level II	579
Level VI	193

### **6.3 Commercial Weigh Scale Operator**

The potential annual dose received by a weigh scale operator ranges from 0.00026 mSv for an operator at a stationary weigh scale to 0.012 mSv for the operator of a portable scale assuming MTO data that suggests that approximately 5% of all trucks are weighed.

Doses calculated for stationary scale operators are assumed to be conservative because of conservative distance assumptions (2 m away from side of truck) and that shielding provided by the structure they are in is not credited. Even with these conservative assumptions, if all 620 UFTP shipments were to be weighed by the same operator, the total received dose would range from 0.005 mSv for an operator at a stationary weigh scale with a large platform to 0.06 mSv for the operator at a weigh scale with a small platform.

Weighings using portable scales are conducted by MTO officers who have stopped a commercial vehicle for potential safety infractions alongside the roadway. As the weight of the UFTP shipments will be very consistent, and MTO will be aware of the UFTP transportation program, the assumption that 31 UFTP shipments will be weighed a given officer is conservative.

### **6.4 Mechanic – Mobile Repair Service Operator**

The potential dose to a mechanic making a minor repair to a UFTP shipment is calculated to be 0.017 mSv. This assumes that the repair required is in very close proximity to the UFTP (0.4 m). While the dose received by the mechanic during the repair is approximately equivalent to two dental x-rays (typically 0.01 mSv per x-ray (Mettler, 2008)), it is highly unlikely that a repair in this location by the same mechanic will be a frequent occurrence. The transport crew will be equipped with dose monitoring equipment and will be trained to instruct the mechanic to minimize exposure by conducting work (when possible) at a greater distance from a loaded package.

## **7. CONCLUSIONS**

Dose rates emitted by a UFTP loaded with 192 bundles of 30 year out-of-reactor CANDU fuel were calculated and presented in NWMO Report TR-2012-06, Generic Transportation Dose Assessment. Using these dose rate data, occupational doses to workers in the proximity of UFTP transport were calculated. Per occurrence dose for activities engaged in by the identified workers was calculated as was the annual dose received by a worker in each category. These results are summarized in Table 15 and Figure 13 below.

In all cases, the maximum individual occupational dose to workers under normal transport conditions was estimated to be below the dose limit for a member of the public (i.e., 1 mSv per year). This assessment concludes that transportation workers would not need to be designated as NEWs.

However, dose rates and resulting occupational doses received by the workers are calculated, and not based on measured values. Dose monitoring of occupational activities will be assessed for drivers and security escorts when the radiation protection plan is developed in support of the operational startup of the used fuel transportation program, including the use of dosimeters worn by the workers.

Driving operations (team driving (straight through) vs. driving with overnight stops) have not been optimized as the eventual repository site destination and associated transport routes are unknown. Driver dose calculations should be re-examined once more route information becomes available.

**Table 15: Occupational Dose Summary**

Worker	Dose per Occurrence [mSv]	Annual Frequency	Annual Dose [mSv]
<b>Driver</b>			
50 km trip	0.0009	295 shipments	0.27
250 km trip	0.0018	164 shipments	0.30
600 km trip	0.0040	86 shipments	0.34
1200 km trip	0.0077	45 shipments	0.34
1700 km trip	0.0111	32 shipments	0.35
2900 km trip	0.0184	19 shipments	0.35
<b>Commercial Vehicle Inspector</b>			
CVSA Level I	0.0035	31 inspections	0.11
CVSA Level II	0.0017	31 inspections	0.054
CVSA Level VI	0.0052	31 inspections	0.16
<b>Weigh Scale Operator</b>			
Large Stationary Scale	0.0000084	31 weighings	0.00026
Small Scale	0.000089	31 weighings	0.0028
Portable Scale	0.0004	31 weighings	0.012
<b>Mechanic – Mobile Repair Service Operator</b>			
	0.017	1 repair	0.017

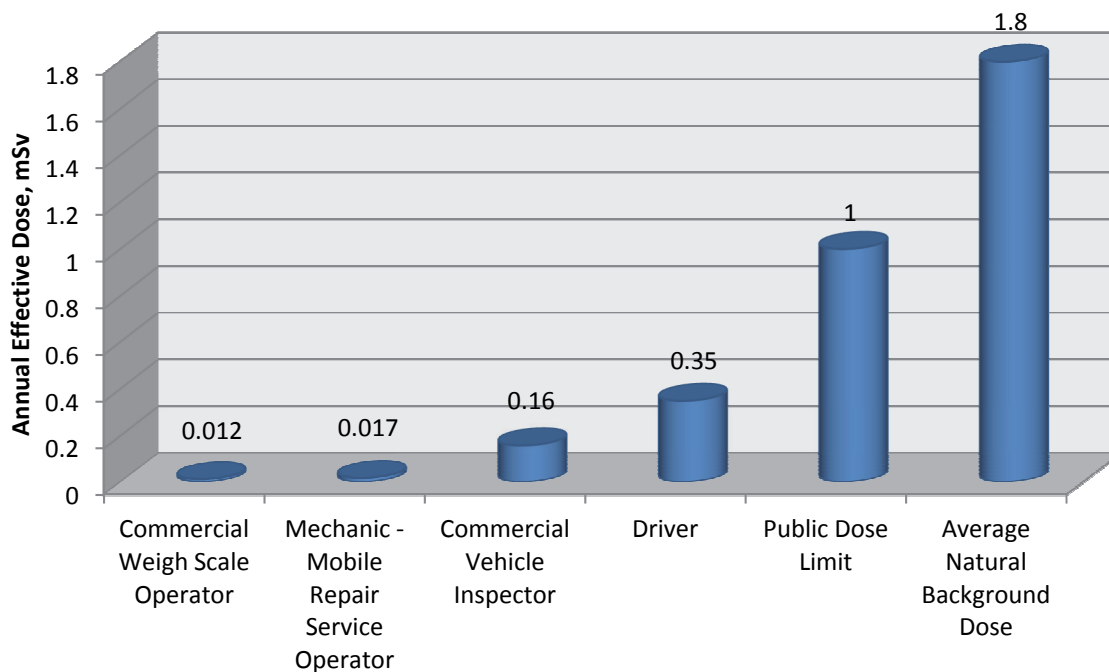

**Figure 13: Comparison of Worker Doses**



Transportation activities assessed in this report focus on workers involved with a UFTP shipment departing the facility at the point of origin to arriving at the destination facility. Specifically the scope of the assessment covers worker activities from the time a used nuclear fuel shipment is loaded on the trailer, departing from the reactor sites to when the trailer arrives at the APM repository site receiving bay and is disconnected. Activities conducted within the boundaries of the associated facilities to prepare a shipment for transport and process a shipment after arrival are not included in the scope of this report (i.e., loading of fuel into the UFTP, on-site transfers of the UFTP, UFTP inspection and testing, loading, securing of the UFTP onto transport trailer at the point of origin and unloading of UFTP at the destination).

Based on the results presented in this report, the doses calculated for transportation workers are below the dose limit for a member of the public (i.e., 1 mSv per year); and, by extension well below the dose limit of 20 mSv per year for NEWs (i.e., the regulatory dose limit of 100 mSv averaged over five years for a Nuclear Energy Worker).

## **ACKNOWLEDGEMENTS**

The preparation of this report could not have been accomplished without the help of individuals in various organizations. The author would like to thank the following individuals for their input and assistance in the gathering of data and determination of activities and scenarios presented.

- Caravan Logistics – Peter Katsoulis, Manager, Training and Case Vanderwel, driver.
- Commercial Vehicle Safety Alliance – Carlisle Smith, Director, Hazardous Materials Programs
- Freiburger and Sons – Marvin Freiburger, proprietor.
- Ontario Ministry of Transportation – Alf Brown, Head Carrier Enforcement Liason, Noris Bot, Manager, Emergency Management and Planning, Blair MacIssac, Manager, Transportation, Mike Wozniack, Transportation Officer.
- Ontario Power Generation – Pauline Witzke, Manager, Radioactive Material Transportation, Luke Keuken, First Line Manager, Radioactive Material Transportation Drivers, Rob Lamont and Chris Lyndon, Transportation Officers.

## REFERENCES

- Batters, S., K. Tsang and U. Stahmer. 2012. Generic Transportation Dose Assessment. Prepared for the NWMO by AMEC NSS Ltd. NWMO Report Number NWMO TR-2012-06. October 2012.
- Canadian Nuclear Safety Commission (CNSC). 2000a. Packaging and Transport of Nuclear Substances Regulations. SOR/2000-208 plus amendments.
- Canadian Nuclear Safety Commission (CNSC). 2000b. Radiation Protection Regulations. SOR 2000/203 plus amendments.
- Canadian Nuclear Safety Commission (CNSC). 2003. Regulatory Guide G-208 – Transportation Security Plans for Category I, II or III Nuclear Material. March 2003.
- Canadian Nuclear Safety Commission (CNSC). 2013. Certificate for Transport Package Design. CDN/2052/B(U)-96. July, 2013.
- City of Kingston (Kingston). 2011. Guidelines for Establishing Posted Speed Limits. Traffic Division, Engineering Department. City of Kingston.
- Garisto, F., T. Kempe, and P. Gierszewski. 2009. Technical Summary of the Safety Aspects of the Deep Geological Repository Concept for Used Nuclear Fuel. NWMO Report No. NWMO TR-2009-12. September 2009.
- International Atomic Energy Agency (IAEA). 2000. Safety Standards Series No. TS-R-1 (ST-1, Revised). Regulations for the Safe Transport of Radioactive Material. 1996 Edition (Revised). Vienna, 2000.
- Los Alamos National Laboratories (LANL). 2003. MCNP – A General Monte Carlo N-Particle Transport Code; Volume 2 – User Manual, Version 5.1.3. LANL Report Number LA-CP-03-0245. April, 2003.
- Metrolinx. 2008. Costs of Road Congestion in the Greater Toronto and Hamilton Area; Impact and Cost-Benefit Analysis of the Metrolinx Draft Regional Transportation Plan. December, 2008.
- Mettler, F.A., W. Huda, T.T. Yoshizumi and M. Mahesh. 2008. Effective Doses in Radiology and Diagnostic Nuclear Medicine. Radiology: Volume 248: Number 1. July, 2008.
- Stahmer, U. 2009. Used Nuclear Fuel Inventory and Transportation Estimates. NWMO Report NWMO TR-2009-21. August 2009.
- Stahmer, U. 2013. Adaptive Phased Management – Used Fuel Transportation Package Safety Analysis Report. NWMO Report APM-SR-00531-0001-R000. July 2013.
- Statistics Canada. 2011. From Urban Areas to Population Centres. <http://www.statcan.gc.ca/subjects-sujets/standard-norme/sqc-cgt/notice-avis/sqc-cgt-06-eng.htm>. February 7, 2011.

Weiner, R.F., M.L. Dennis, D. Hinojosa, T.J. Heames, J.J. Penisten, M.K. Marincel, and D.M. Osborn. 2009. RadCat 3.0 User Guide. Sandia National Laboratories. Albuquerque, NM. May 2009.

Wilk, L. 2013. NWMO. CANDU Fuel Burnup and Power Rating 2012 Update. Prepared for the NWMO by AMEC NSS Ltd. NWMO Report Number NWMO TR-2013-02. February 2013.

## APPENDIX A: RATIONALE FOR LIMITING SCOPE TO WORKERS WITHIN 30 M OF PACKAGE

### Assumptions

- Worker is present at 30 m from UFTP every work day for the entire day
- Worker works 8 h per day, 5 days per week, 50 weeks per year = 2000 h/y

### Data

- Dose from UFTP at 30 m (220 MWh/kgU) 0.000015 mSv/h (1)
- Regulatory limit for non-NEW 1 mSv/y (2)
- Regulatory limit for NEW 100 mSv / 5 y (2)  
50 mSv/y maximum
- Annualized dose limit for NEWs<sup>1</sup> 20 mSv/y

### Calculation

$$\begin{aligned} \text{Annual dose to worker at 30 m from UFTP} &= 0.000015 \text{ mSv/h} \times 2000 \text{ h} \\ &= 0.03 \text{ mSv/y} \end{aligned}$$

### Comparisons

Dose to worker from UFTP at 30 m is approximately equivalent to:

- 3% of regulatory limit for the general public
- 0.15% of the dose limit for Nuclear Energy Workers

### Conclusions

The annual dose to a worker situated 30 m from a UFTP every day for the entire workday is estimated to be 0.03 mSv/y or 3% of the regulatory limit for the general public. Thus the radiological dose due to the transport of used nuclear fuel to workers engaged in activities at distances greater than 30 m from the UFTP is considered negligible. Only activities placing workers at distances within 30 m of the UFTP are included in this assessment.

### References

- (1) Batters, S., K. Tsang and U. Stahmer. 2012. Generic Transportation Dose Assessment. Prepared for the NWMO by AMEC NSS Ltd. NWMO Report Number NWMO TR-2012-06. October 2012.
- (2) Canadian Nuclear Safety Commission (CNSC). 2000. Radiation Protection Regulations. SOR/2000-203 plus amendments.

---

<sup>1</sup> For the purpose of this assessment, doses to workers are compared to an dose limit of 20 mSv/year for NEWs (i.e., the regulatory dose limit of 100 mSv averaged over five years for Nuclear Energy Workers).



## APPENDIX B: TRANSPORT ACTIVITIES AND DOSE CALCULATIONS

### B.1 TRACTOR-TRAILER HOOKUP / UNHOOK

Performed by: Driver

Requirement: Operational procedures

Description: A UFTP trailer is hooked up to the tractor unit prior to departure or unhooked from the tractor unit after arrival. See Figure B-1 below.

Duration: Hooking up or unhooking the trailer from the tractor typically takes 5 minutes broken down as follows:

- 2 min at 4 m to raise / lower landing gear
- 2 min at 7 m to connect / disconnect electrical and pneumatic hookups
- 1 min at 8 m driving in the cab to connect / disconnect the trailer

Distance: Driver is located 4, 7 and 8 m from the front surface of the UFTP (see Figure B-1).

Frequency: One hookup and one unhook per shipment.

Time references: Ontario Power Generation, Caravan Logistics

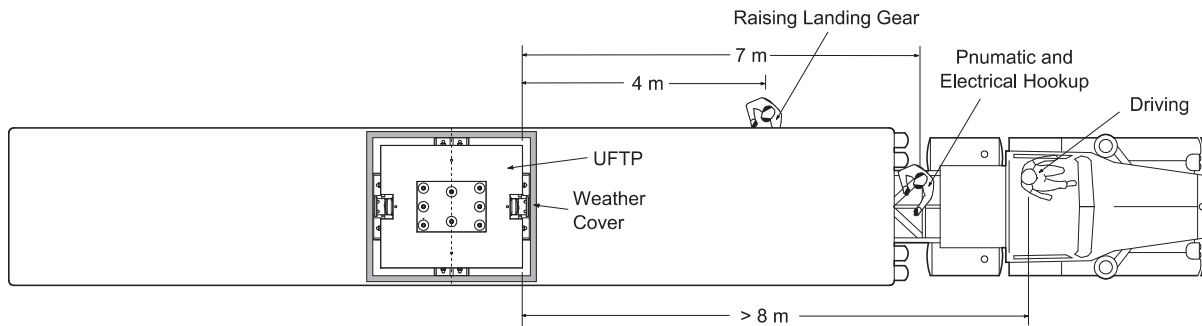

Figure B-1: UFTP Tractor and Trailer being Hooked up or Unhooked

### **Driver Dose Calculation – Tractor-Trailer Hookup / Unhook**

The driver will receive dose from the shipment during tractor-trailer connect/disconnect operations. Shielding provided by the vehicle is not credited.

#### **Dose received during raising and lowering of landing gear**

Dose rate at 4 m = 0.0008 mSv/h (see Figure 4 in main report)

$$\begin{aligned} \text{Dose} &= \text{dose rate} \times \text{duration} \\ &= 0.0008 \text{ mSv/h} \times (2 \text{ min}) \\ &= 2.7 \times 10^{-5} \text{ mSv} \end{aligned}$$

#### **Dose received during connection / disconnection of electrical and pneumatic lines**

Dose rate at 7 m = 0.00025 mSv/h (see Figure 4 in main report)

$$\begin{aligned} \text{Dose} &= \text{dose rate} \times \text{duration} \\ &= 0.00025 \text{ mSv/h} \times (2 \text{ min}) \\ &= 8.3 \times 10^{-6} \text{ mSv} \end{aligned}$$

#### **Dose received during connection / disconnection of tractor**

Dose rate at 8 m = 0.00020 mSv/h (see Figure 4 in main report)

$$\begin{aligned} \text{Dose} &= \text{dose rate} \times \text{duration} \\ &= 0.00020 \text{ mSv/h} \times (1 \text{ min}) \\ &= 3.3 \times 10^{-6} \text{ mSv} \end{aligned}$$

#### **Total dose received during hookup / unhook**

$$\begin{aligned} \text{Total Dose} &= \text{Dose at 4 m} + \text{Dose at 7 m} + \text{Dose at 8 m} \\ &= 2.7 \times 10^{-5} \text{ mSv} + 8.3 \times 10^{-6} \text{ mSv} + 3.3 \times 10^{-6} \text{ mSv} \\ &= 3.8 \times 10^{-5} \text{ mSv} \end{aligned}$$

The dose received by the driver during a tractor-trailer hookup or unhook operation is  $3.8 \times 10^{-5}$  mSv.



## B.2 DOCUMENTATION CHECK

Performed by: Driver

Requirement: In accordance with CNSC Regulatory Guide G-208 – Transportation Security Plans for Category I, II or III Nuclear Material.

Description: Driver is in tractor cab reviewing shipment documentation, bills of lading and manifests. See Figure B-2 below.

Duration: Typically 15 minutes.

Distance: Driver is located in the cab of the tractor approximately 8 m in front of the UFTP as shown in Figure B-2. No credit is given to any additional shielding provided by the tractor-trailer.

Frequency: Each shipment - prior to departure and upon arrival at destination

Time, distance and frequency references: Ontario Power Generation, Caravan Logistics.

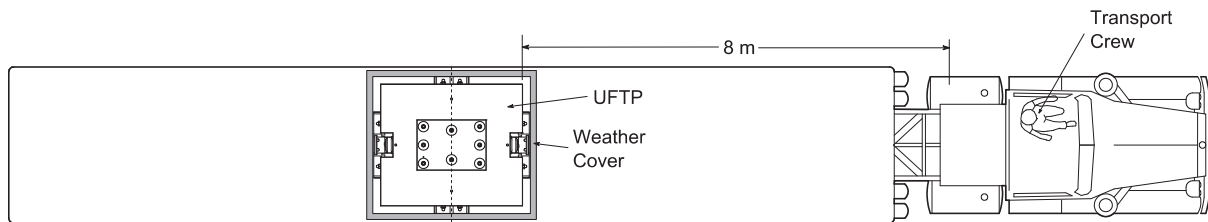

**Figure B-2: Documentation Check prior to and post Shipment**

### **Driver Dose Calculation – Documentation Check**

The driver may receive dose from the shipment during documentation check operations. Shielding provided by the vehicle is not credited.

Note, conservatively, this operation is assumed to take place in the tractor cab. However, it can take place at a location at a greater distance

### **Dose received during documentation check**

$$\begin{aligned} \text{Dose rate at 8 m} &= 0.00020 \text{ mSv/h (see Figure 4 in main report)} \\ \text{Dose} &= \text{dose rate} \times \text{duration} \\ &= 0.00020 \text{ mSv/h} \times (15 \text{ min}) \\ &= 5.0 \times 10^{-5} \text{ mSv} \end{aligned}$$

The dose received by the driver during a document check is  $5.0 \times 10^{-5}$  mSv.

### B.3 REST / RELIEF STOP

Performed by: Transport Crew (Driver and Security Escort)

Requirement: In accordance with CNSC Regulatory Guide G-208 – Transportation Security Plans for Category I, II or III Nuclear Material, once loaded and in transit, the vehicle should never be left unattended.

Description: One crew member is attending to vehicle while other crew member goes for rest / food / relief. See Figure B-3 below.

Duration: Typically 30 minutes.

Distance: The transport crew is located in the cab of the tractor approximately 8 m in front of the UFTP as shown in Figure B-3. No credit is given to any additional shielding provided by the tractor-trailer.

Frequency: One stop for every 400 km travelled. All trips over 200 km in length are assumed to have at least one stop.

Time, distance and frequency references: Ontario Power Generation, Caravan Logistics.

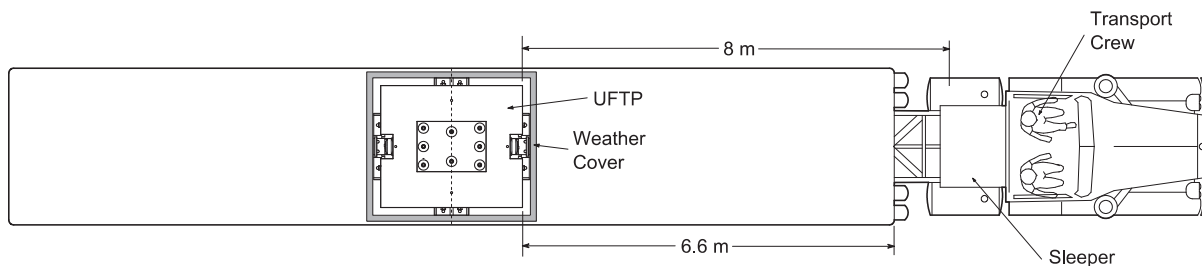

**Figure B-3: UFTP Shipment during Transport**

### **Driver Dose Calculation – Rest / Relief Stop**

The driver will receive dose from the shipment during a rest stop. Shielding provided by the vehicle is not credited.

#### **Dose received during rest stop**

$$\begin{aligned} \text{Dose rate at 8 m} &= 0.00020 \text{ mSv/h (see Figure 4 in main report)} \\ \text{Dose} &= \text{dose rate} \times \text{duration} \\ &= 0.00020 \text{ mSv/h} \times (0.5 \text{ h}) \\ &= 1.0 \times 10^{-4} \text{ mSv} \end{aligned}$$

The dose received by the driver during a rest stop is  $1.0 \times 10^{-4}$  mSv.

## B.4 REFUELLING – UFTP TRACTOR-TRAILER

- Performed by: Driver / Security Escort in Cab / Commercial Driver at adjacent pump
- Requirement: Only trips of 1400 km or more require refuelling with loaded UFTP
- Description: Driver stands beside vehicle during refuelling. Security escort remains in tractor cab. Commercial driver refuels commercial vehicle at adjacent pump. See Figure B-4 below.
- Duration: One vehicle refuelling stop is typically 20 minutes in length.
- Distance: Driver is located 6 m from the UFTP. Security Escort is located 8 m from the UFTP. Commercial driver is located at 3 m from the UFTP (see Figure B-4).
- Frequency: Frequency is calculated based on trip length. See Calculations in Appendix B-5. Presence of a given commercial driver at a refuelling stop is assumed to be a singular event.
- Time, distance and frequency references: Caravan Logistics, Ontario Power Generation

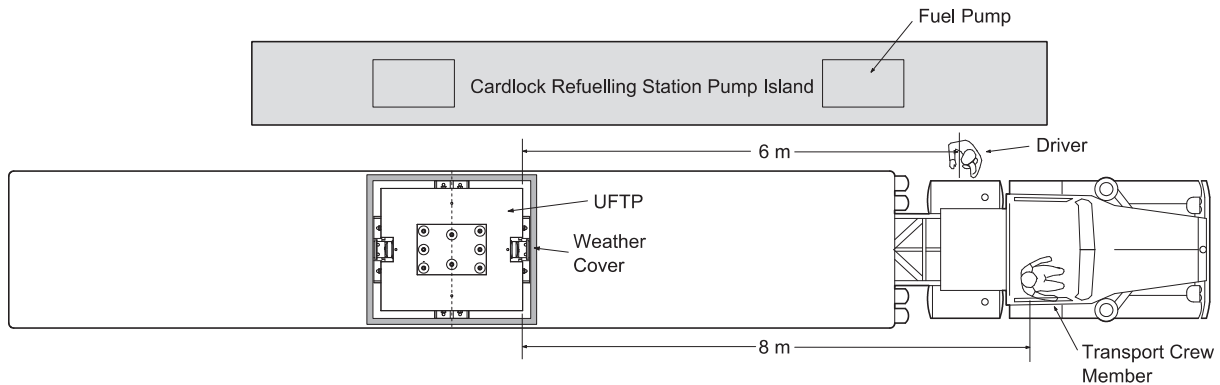

**Figure B-4: UFTP Shipment in Cardlock Refuelling Station**

### **Driver Dose Calculation - Refuelling**

The driver will receive dose from the shipment during refuelling of the UFTP tractor-trailer. Shielding provided by the vehicle is not credited.

#### **Dose received during refuelling**

$$\begin{aligned} \text{Dose rate at 6 m} &= 0.00035 \text{ mSv/h (see Figure 4 in main report)} \\ \text{Dose} &= \text{dose rate} \times \text{duration} \\ &= 0.00035 \text{ mSv/h} \times (0.33 \text{ h}) \\ &= 1.2 \times 10^{-4} \text{ mSv} \end{aligned}$$

The dose received by the driver during refueling is  $1.2 \times 10^{-4}$  mSv.

## B.5 EN-ROUTE TRANSPORT AND DRIVER DOSE CALCULATION

Performed by: Transport Crew (Driver and Security Escort)

Requirement: In accordance with Ontario Regulation 555/06, Hours of Service.

Description: Crew is in UFTP tractor cab driving en-route to repository. See Figure B-5 below.

Duration: In transit time is dependent on trip length. Transit times for various trip lengths are calculated in Table 6 of main report.

Distance: The transport crew is located in the cab of the tractor approximately 8 m in front of the UFTP as shown in Figure B-5. No credit is given to any additional shielding provided by the tractor-trailer.

Frequency: Frequency is calculated based on trip length. See calculations in Table 9 of main report

Time, distance and frequency references: See calculations in Tables 6 and 9 of main body.

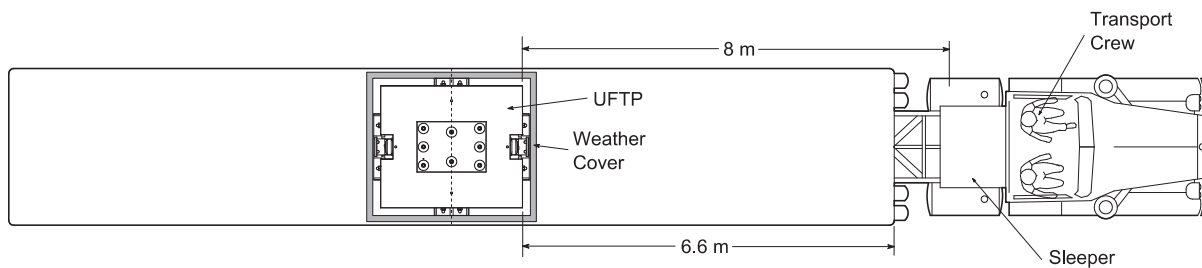

**Figure B-5: UFTP Shipment during Transport**

### **Driver Dose Calculation**

The driver will receive a radiological dose from the shipment during various transportation activities. The dose received during transport is the sum of all the doses received during each activity.

### **Dose received during transport**

The doses received by the driver during pre- and post-shipment activities and while en-route are tabulated in Table B-5-1. Additional shielding provided by trailer deck is not credited in the calculations.

### **Annual dose received by driver**

The estimated annual doses received by a driver are presented in Table B-5-2.

### **Conclusions**

The annual dose to a driver or transport crew member ranges between 0.27 mSv per year and 0.35 mSv per year, which is less than the regulatory public dose limit.



**Table B-5-1: Driver Dose Summary – Per-Shipment Dose**

Doses in mSv	Shipment Length					
	50 km	250 km	600 km	1200 km	1700 km	2900 km
<b>Pre-shipment Activities</b>						
Trailer Hookup	0.000038	0.000038	0.000038	0.000038	0.000038	0.000038
Documentation Check	0.000050	0.000050	0.000050	0.000050	0.000050	0.000050
Condition Inspection	0.00058	0.00058	0.00058	0.00058	0.00058	0.00058
Pre-shipment Total	0.00066	0.00066	0.00066	0.00066	0.00066	0.00066
<b>En-route Activities</b>						
Driving (time: hh:mm)	0.00015 (0:44)	0.00095 (4:45)	0.0020 (9:51)	0.0037 (18:38)	0.0052 (26:00)	0.0087 (43:30)
Rest Stops (frequency)	0.00 (0)	0.00010 (1)	0.00010 (1)	0.00030 (3)	0.00040 (4)	0.00070 (7)
Condition Inspections (frequency)	0.00 (0)	0.00 (0)	0.0012 (2)	0.0029 (5)	0.0046 (8)	0.0081 (14)
Refuelling (frequency)	0.00 (0)	0.00 (0)	0.00 (0)	0.00 (0)	0.00012 (1)	0.00023 (2)
<b>Post-shipment Activities</b>						
Trailer Unhook	0.000038	0.000038	0.000038	0.000038	0.000038	0.000038
Documentation Check	0.000050	0.000050	0.000050	0.000050	0.000050	0.000050
Post-Shipment Total	0.000088	0.000088	0.000088	0.000088	0.000088	0.000088
<b>Per-Shipment Dose</b>	<b>0.0009</b>	<b>0.0018</b>	<b>0.0040</b>	<b>0.0077</b>	<b>0.011</b>	<b>0.018</b>

**Table B-5-2: Driver Dose Summary – Annual Dose**

Doses in mSv	Shipment Length					
	50 km	250 km	600 km	1200 km	1700 km	2900 km
Annual Shipments	295	164	86	45	32	19
<b>Pre-shipment Activities</b>						
Trailer Hookup	0.011	0.006	0.003	0.002	0.001	0.001
Documentation Check	0.015	0.008	0.004	0.002	0.002	0.001
Condition Inspection	0.17	0.094	0.050	0.026	0.018	0.011
<b>Pre-shipment Total</b>	<b>0.20</b>	<b>0.11</b>	<b>0.057</b>	<b>0.030</b>	<b>0.021</b>	<b>0.013</b>
<b>En-route Activities</b>						
Driving	0.044	0.16	0.17	0.17	0.17	0.17
Rest Stops	0.00	0.016	0.009	0.014	0.013	0.013
Condition Inspections	0.00	0.00	0.099	0.13	0.15	0.15
Refuelling	0.00	0.00	0.00	0.00	0.004	0.004
<b>En-route Total</b>	<b>0.044</b>	<b>0.17</b>	<b>0.277</b>	<b>0.31</b>	<b>0.33</b>	<b>0.34</b>
<b>Post-shipment Activities</b>						
Trailer Unhook	0.011	0.006	0.003	0.002	0.001	0.001
Documentation Check	0.015	0.008	0.004	0.002	0.002	0.001
<b>Post-shipment Total</b>	<b>0.026</b>	<b>0.014</b>	<b>0.008</b>	<b>0.004</b>	<b>0.003</b>	<b>0.002</b>
<b>Annual Driver Dose</b>	<b>0.27</b>	<b>0.30</b>	<b>0.34</b>	<b>0.34</b>	<b>0.35</b>	<b>0.35</b>

## B.6 VEHICLE INSPECTIONS

Performed by: Vehicle Inspector / Driver

Requirement: In accordance with the Ontario Highway Traffic Act R.S.O. 1990, Chapter H.8 Section 216.1, a commercial vehicle may be stopped, and the vehicle, equipment and contents may be examined.  
Additionally, in accordance with O. Reg. 199/07, s. 8 (1), a driver shall monitor the condition of each commercial motor vehicle and trailer he or she is driving, drawing or in charge of to detect the presence of a major or minor defect.

Description: The UFTP tractor-trailer is inspected by an inspector to the requirements of the Commercial Vehicle Safety Alliance (CVSA) Level I, Level II or Level VI inspections or by the driver to the requirements of an en-route vehicle condition inspection. Figure B-6-1 below shows the elements of a systematic circle check of the vehicle which provides the basis for all inspections.

Duration: Time required to inspect the vehicle is dependent on the inspection level.

- Level I Inspection: 1 hour
- Level II Inspection: ½ hour
- Level VI Inspection: 1½ hours
- Condition Inspection: 10 minutes

Distance: Inspector or driver is located less than 1 m from side of the truck while performing the circle check. Level I and Level VI inspections also require inspector to inspect the underside of the vehicle.

For dose calculations, the circle check around the vehicle is divided into 46 areas within 12 zones (numbered 0 through 11). Each area is 1 m wide and extends outward 1 m from the vehicle. The areas and zones are illustrated in Figure B-6-2. Inspection time is assumed to be distributed equally between the 46 areas. The distance between the UFTP and the area is approximated by the number of the zone (i.e.: an inspector in an area in Zone 2 is located approximately 2 m from the UFTP).

Frequency: CVSA inspection frequency for a given vehicle is unknown. Ontario Ministry of Transportation inspects approximately 110,000 vehicles per year.

For dose calculations, 5% of all UFTP shipments are assumed to be stopped and inspected by the same inspector.

En-route vehicle condition inspections are conducted by the driver prior to departure and once for approximately every 200 km traveled. En-route vehicle condition inspections are not required for trips under 300 km in length.

Time, distance and frequency references: Ontario Ministry of Transportation (MTO),  
Ontario Power Generation (OPG),  
Caravan Logistics  
Commercial Vehicle Safety Alliance

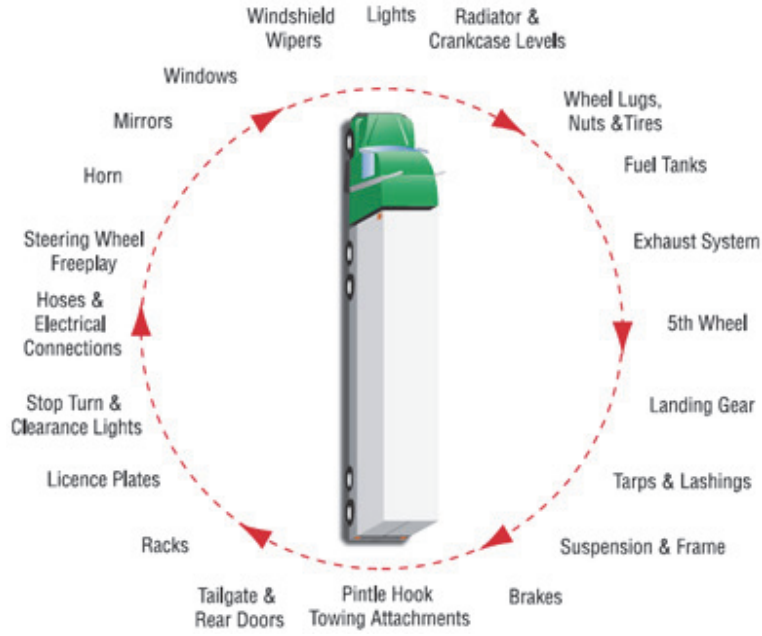

Source: Ontario Ministry of Transportation (MTO)

**Figure B-6-1: Commercial Vehicle Circle Check**

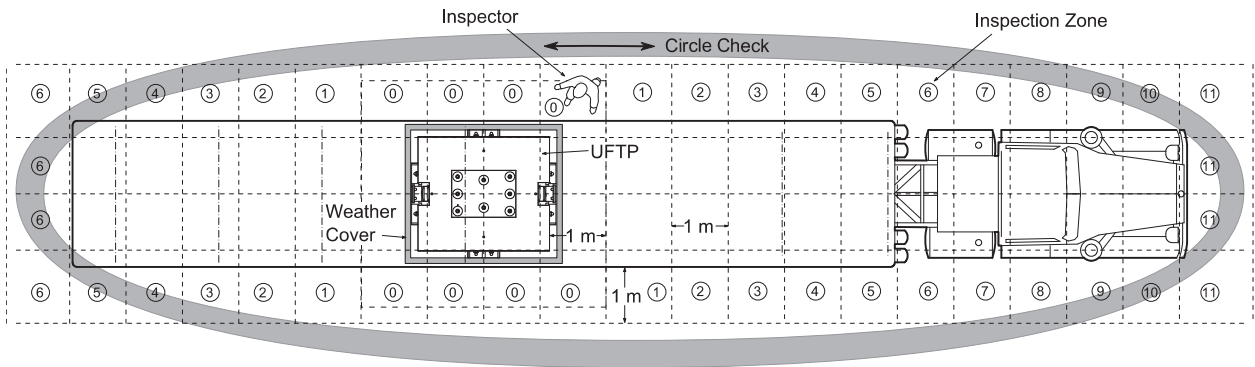

**Figure B-6-2: UFTP Vehicle Inspection Areas and Zones**

### Inspection Dose Calculation

The inspector or driver will receive a radiological dose from the shipment during the inspection. The dose received during the inspection is the sum of the doses received in each zone.

### Dose received during Inspection

The doses received by the inspector or driver during a CVSA Level I, II and VI inspection and vehicle condition assessment by the driver are tabulated in Table B-6-2. Additional shielding provided by trailer deck is not credited in the calculations.

The dose of 0.0045 mSv in one hour represents an average distance of 1.2 m from the UFTP during the entire inspection.

### Annual dose received by Inspector

Assuming that the inspector inspects 5% of all UFTP shipments (31 shipments) per year, the estimated annual doses received by an inspector are presented in Table B-6-1.

**Table B-6-1: Dose Received during Inspection**

Inspection Type	Dose per Inspection [mSv]	Number of Inspections by given Inspector	Annual Dose [mSv]
CVSA Level I	0.0035	31	0.11
CVSA Level II	0.0017	31	0.054
CVSA Level VI	0.0052	31	0.16

Note: Figures rounded to 2 significant digits. Annual dose may not be exact product due to round-off.

### Annual dose received by Driver

The vehicle condition assessment is one of numerous activities performed by the driver. Annual dose received by the driver is presented in Appendix B-5

### Conclusions:

The annual dose to an inspector carrying out 31 CVSA Level VI inspections of a UFTP shipment is estimated to be 0.16 mSv, which is less than the regulatory public dose limit.

**Table B-6-2: Dose Received during Inspection**

Zone	Average Distance from UFTP	Dose rate [mSv/h] <sup>1</sup>	Frequency in Zone during Circle Check	Condition Assessment		CVSA Level I		CVSA Level II		CVSA Level VI	
				Time [mm:ss]	Dose [mSv]	Time [mm:ss]	Dose [mSv]	Time [mm:ss]	Dose [mSv]	Time [mm:ss]	Dose [mSv]
0	0.4 m	0.014	8	01:44	4.0 x 10 <sup>-4</sup>	10:26	2.4 x 10 <sup>-3</sup>	05:13	1.2 x 10 <sup>-3</sup>	15:39	3.6 x 10 <sup>-3</sup>
1	1 m	0.0060	4	00:52	8.6 x 10 <sup>-5</sup>	05:13	5.2 x 10 <sup>-4</sup>	02:37	2.6 x 10 <sup>-4</sup>	07:50	7.8 x 10 <sup>-4</sup>
2	2 m	0.0024	4	00:52	3.5 x 10 <sup>-5</sup>	05:13	2.1 x 10 <sup>-4</sup>	02:37	1.1 x 10 <sup>-4</sup>	07:50	3.2 x 10 <sup>-4</sup>
3	3 m	0.0012	4	00:52	1.7 x 10 <sup>-5</sup>	05:13	1.0 x 10 <sup>-4</sup>	02:37	5.2 x 10 <sup>-5</sup>	07:50	1.6 x 10 <sup>-4</sup>
4	4 m	0.00080	4	00:52	1.2 x 10 <sup>-5</sup>	05:13	7.0 x 10 <sup>-5</sup>	02:37	3.5 x 10 <sup>-5</sup>	07:50	1.0 x 10 <sup>-4</sup>
5	5 m	0.00052	4	00:52	7.5 x 10 <sup>-6</sup>	05:13	4.5 x 10 <sup>-5</sup>	02:37	2.3 x 10 <sup>-5</sup>	07:50	6.8 x 10 <sup>-5</sup>
6	6 m	0.00035	6	01:18	7.6 x 10 <sup>-6</sup>	07:50	4.6 x 10 <sup>-5</sup>	03:55	2.3 x 10 <sup>-5</sup>	11:44	6.8 x 10 <sup>-5</sup>
7	7 m	0.00025	2	00:26	1.8 x 10 <sup>-6</sup>	02:37	1.1 x 10 <sup>-5</sup>	01:18	5.4 x 10 <sup>-6</sup>	03:55	1.6 x 10 <sup>-5</sup>
8	8 m	0.00020	2	00:26	1.4 x 10 <sup>-6</sup>	02:37	8.7 x 10 <sup>-6</sup>	01:18	4.3 x 10 <sup>-6</sup>	03:55	1.3 x 10 <sup>-5</sup>
9	9 m	0.00016	2	00:26	1.2 x 10 <sup>-6</sup>	02:37	7.0 x 10 <sup>-6</sup>	01:18	3.5 x 10 <sup>-6</sup>	03:55	1.0 x 10 <sup>-5</sup>
10	10 m	0.00013	2	00:26	9.8 x 10 <sup>-7</sup>	02:37	5.9 x 10 <sup>-6</sup>	01:18	2.9 x 10 <sup>-6</sup>	03:55	8.8 x 10 <sup>-6</sup>
11	11 m	0.00012	4	00:52	1.7 x 10 <sup>-6</sup>	05:13	1.0 x 10 <sup>-5</sup>	02:37	5.2 x 10 <sup>-6</sup>	07:50	1.6 x 10 <sup>-5</sup>
<b>Totals</b>			<b>46</b>	<b>10:00</b>	<b>0.00058</b>	<b>60:00</b>	<b>0.0035</b>	<b>30:00</b>	<b>0.0017</b>	<b>90:00</b>	<b>0.0052</b>

1 – See Figure 4 in main report.

Note: Figures rounded to 2 significant digits. Sums of columns may differ from totals due to round-off.

## **B.7 WEIGHING AT WEIGH STATION**

Performed by: Weigh Scale Operator

Requirement: In accordance with the Ontario Highway Traffic Act R.S.O. 1990, Chapter H.8 Section 124, a vehicle may be stopped, weighed and examined.

Description: A UFTP shipment is weighed at a stationary weigh scale. See Figure B-6 below.

Duration: One vehicle weighing stop is typically 2 minutes in length (0.033 h).

For dose calculations, the dose received by the weigh scale operator is assumed to be the sum of the dose received during the 2 minute weighing and the dose received as the UFTP tractor trailer exits the inspection station. While exiting the weigh scale, a vehicle speed of 5 km per hour is assumed.

Distance: Weigh scale operator is located 2 m from the cab of the tractor-trailer unit. This equates to approximately 9 m from the front surface of the UFTP (see Figure B-7-1) during the weighing and 2 m from the UFTP as the tractor trailer exits the weigh station.

For weigh scales with small weigh platforms, front and rear axle groupings are weighed independently. Weigh scale operator may be within 2 m of the UFTP during weighing of rear axle grouping. See Figure B-7-2.

Frequency: Frequency of weighing at weigh station is unknown. Ontario Ministry of Transportation inspects approximately 110,000 vehicles per year. The number of commercial vehicles weighed is significantly higher.

For dose calculations, 5% of all UFTP shipments are assumed to be stopped and weighed at a weigh station by the same weigh scale operator.

Time, distance and frequency references: Ontario Ministry of Transportation (MTO)

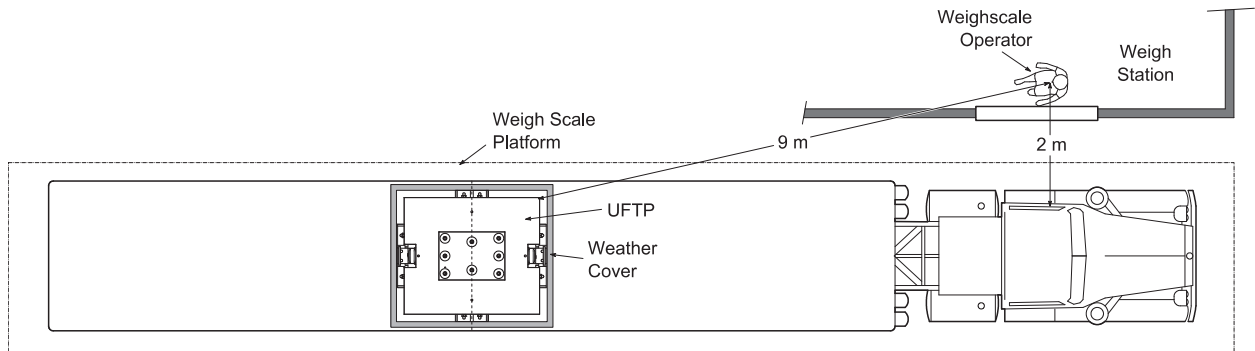

**Figure B-7-1: UFTP Shipment in Stationary Weigh Scale (Large Platform)**

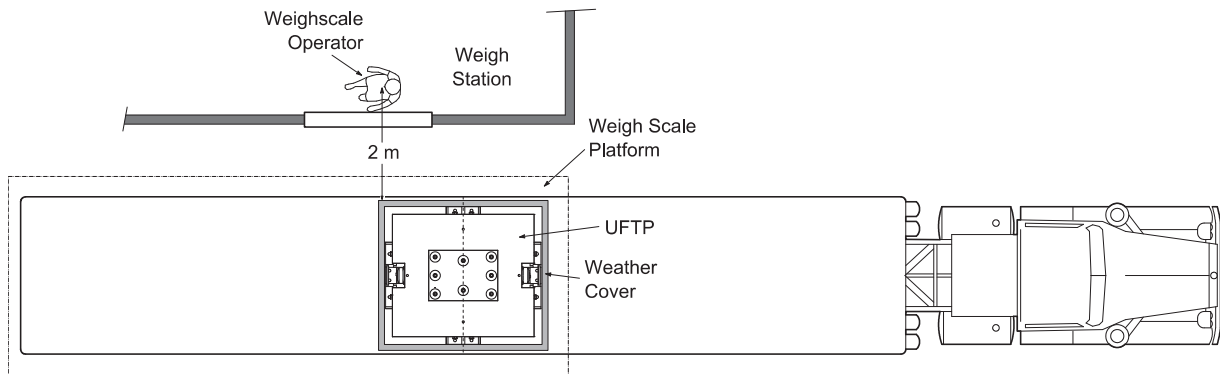

**Figure B-7-2: UFTP Shipment in Stationary Weigh Scale (Small Platform)**  
(Weighing of Rear Axle Group)



### **Weigh Scale Operator Dose Calculation**

The weigh scale operator will receive dose from the shipment during the weighing and from the slow moving shipment as the shipment exits the scale. The dose received by the weigh scale operator is the sum of these two doses. Shielding provided by the building is not credited.

#### **Dose received during weighing (large platform and front axle group of small platform)**

$$\begin{aligned} \text{Dose rate at 9 m} &= 0.00016 \text{ mSv/h (see Figure B-7-1)} \\ \text{Dose} &= \text{dose rate} \times \text{duration} \\ &= 0.00016 \text{ mSv/h} \times 0.033 \text{ h} \\ &= 5.33 \times 10^{-6} \text{ mSv} \end{aligned}$$

#### **Dose received during weighing (small platform rear axle group)**

$$\begin{aligned} \text{Dose rate at 2 m} &= 0.00242 \text{ mSv/h (see Figure B-7-2)} \\ \text{Dose} &= \text{dose rate} \times \text{duration} \\ &= 0.00242 \text{ mSv/h} \times 0.033 \text{ h} \\ &= 8.07 \times 10^{-5} \text{ mSv} \end{aligned}$$

#### **Dose received from passing slow-moving UFTP shipment**

Dose received by a stationary receptor from moving source is presented in Appendix C. Using the method described, the dose received by the weigh scale operator at 2 m from side of truck as it passes at 5 km/h is  $3.04 \times 10^{-6}$  mSv.

#### **Total dose received by weigh scale operator during weighing (large platform)**

$$\begin{aligned} \text{Total Dose} &= \text{dose during weighing} + \text{dose due to drive-by} \\ &= 5.33 \times 10^{-6} \text{ mSv} + 3.04 \times 10^{-6} \text{ mSv} \\ &= 8.4 \times 10^{-6} \text{ mSv} \end{aligned}$$

The dose received by the weigh scale operator during the weighing is  $8.4 \times 10^{-6}$  mSv.

#### **Total dose received by weigh scale operator during weighing (small platform)**

$$\begin{aligned} \text{Total Dose} &= \text{dose during weighing front axle group} + \text{rear axle group} \\ &\quad + \text{dose due to drive-by} \\ &= 5.33 \times 10^{-6} \text{ mSv} + 8.07 \times 10^{-5} \text{ mSv} + 3.0 \times 10^{-6} \text{ mSv} \\ &= 8.9 \times 10^{-5} \text{ mSv} \end{aligned}$$

The dose received by the weigh scale operator during the weighing is  $8.9 \times 10^{-5}$  mSv.

### **Annual dose received by weigh scale operator**

Assume 5% of shipments (31 shipments) are weighed at stationary weigh scales per year by the same weigh scale operator:

#### **Large platform**

$$\begin{aligned} \text{Dose} &= 8.4 \times 10^{-6} \text{ mSv} \times 31 \text{ shipments} \\ &= 0.00026 \text{ mSv (0.026 \% of regulatory dose limit)} \end{aligned}$$

The annual dose received by a large platform weigh scale operator is 0.00026 mSv.

If all 620 shipments are weighed by same operator, the annual dose is 0.0052 mSv.

#### **Small platform**

$$\begin{aligned} \text{Dose} &= 8.9 \times 10^{-5} \text{ mSv} \times 31 \text{ shipments} \\ &= 0.0028 \text{ mSv (0.28 \% of regulatory dose limit)} \end{aligned}$$

The annual dose received by a small platform weigh scale operator is 0.0028 mSv.

If all 620 shipments are weighed by same operator, the annual dose is 0.055 mSv.

### **Conclusions**

The radiological dose due to used fuel transportation estimated to be received by a weigh scale operator is 0.00026 mSv, which is less than the regulatory dose limit for the public.

## B.8 WEIGHING WITH PORTABLE SCALE

Performed by: Portable Weigh Scale Operator

Requirement: In accordance with the Ontario Highway Traffic Act R.S.O. 1990, Chapter H.8 Section 124, a vehicle may be stopped, weighed and examined.

Description: UFTP tractor-trailer is weighed using a portable weigh scale. See Figure B-8 below.

Duration: Time required to weigh tractor-trailer is typically 15 minutes (0.25 h).

Distance: Weigh scale operator is located less than 1 m from side of the tractor-trailer. Weigh scale operator places scales in front of each of the 7 axles one axle at a time and tractor-trailer moves forward onto scales for weighing. Relative distances between the operator position at each axle and the surface of the UFTP are shown in Figure B-8. Time required to weigh each axle is assumed to be the same.

Frequency: Frequency of weighing with portable scales is unknown. Ontario Ministry of Transportation inspects approximately 110,000 vehicles per year. The number of commercial vehicles weighed at government and commercial weigh stations is significantly higher.

For dose calculations, 5% of all UFTP shipments are assumed to be stopped and weighed with a portable weigh scale by the same weigh scale operator.

Time, distance and frequency references: Ontario Ministry of Transportation (MTO)

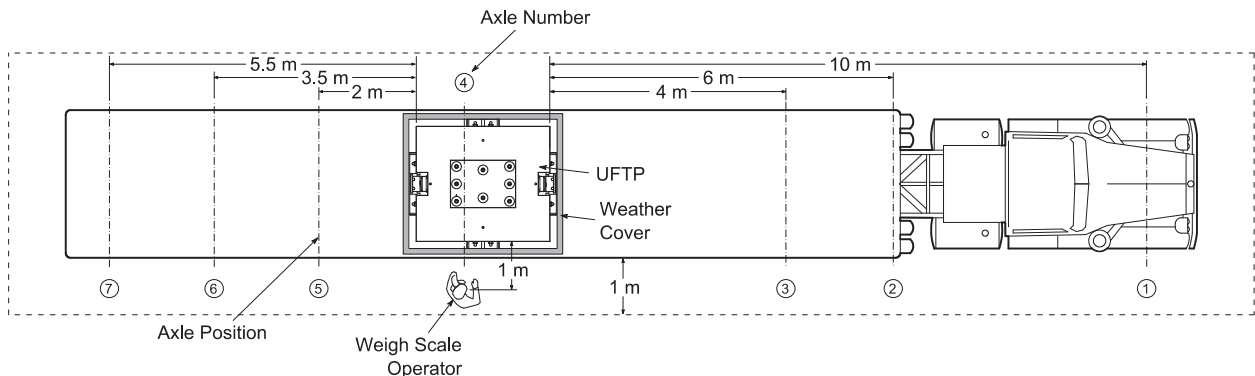

**Figure B-8: UFTP Shipment weighed with Portable Weigh Scale**

### Portable Weigh Scale Operator Dose Calculation

The portable weigh scale operator will receive dose from the shipment during the weighing of each axle. The dose received by the portable weigh scale operator is the sum of the doses received at each axle.

#### Dose received during Weighing

The dose to the portable weigh scale operator is calculated in Table B-8. Additional shielding provided by trailer deck is not credited.

**Table B-8: Dose Received during Weighing with Portable Scale**

Axle	Distance from UFTP [m]	Dose rate [mSv/h] <sup>1</sup>	Time [min]	Dose [mSv]
1	10	0.00013	2:09	0.000005
2	6	0.00035	2:09	0.000013
3	4	0.0008	2:09	0.000029
4	1	0.0060	2:09	0.00022
5	2	0.0024	2:09	0.000086
6	3.5	0.0010	2:09	0.000036
7	5.5	0.00042	2:09	0.000015
<b>Totals</b>			<b>15</b>	<b>0.00040</b>

1 – See Figure 4 in main report.

A dose of 0.00040 mSv for one weighing is equivalent to 0.0016 mSv in one hour which represents an average distance of 2.5 m (see Figure 4 in main report) from the UFTP during the entire weighing.

#### Annual dose received by weigh scale operator

Assume operator weighs 5% of shipments (31 shipments) per year:

$$\begin{aligned} \text{Dose} &= 4.0 \times 10^{-4} \text{ mSv} \times 31 \text{ shipments} \\ &= 0.012 \text{ mSv (1.2\% of public dose limit)} \end{aligned}$$

The annual dose received by a portable weigh scale operator is 0.012 mSv.

If all 620 shipments are weighed by same operator, the annual dose is 0.25 mSv.

#### Conclusions:

The annual dose due to the weighing of the UFTP shipment estimated to be received by a portable weigh scale operator is 0.012 mSv, which is less than the regulatory public dose limit.

### B.9 MINOR BREAKDOWN OR TIRE REPAIR

Performed by: Mechanic / Tow Truck Operator

Requirement: ALARA

Description: A malfunction or broken part on the UFTP tractor-trailer is repaired en-route. See Figure B-9 below.

Duration: Changing the inner tire of a dual tire pair typically requires 1 hour. Repair of a maxi-pot brake chamber typically requires ½ hour.

Distance: Mechanic is located 0.4 m from the UFTP (see Figure B-9) for the tire repair and at 1 m for the maxi-pot repair.

Frequency: Singular event.

Time, distance and frequency references: Caravan, Marvin Freiburger and Sons.

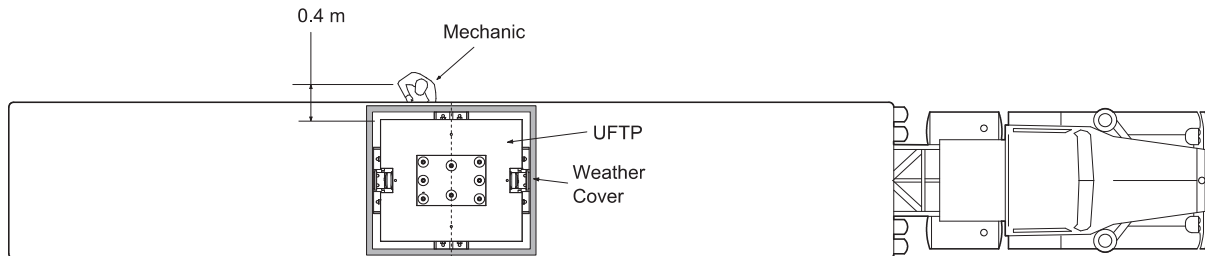

**Figure B-9: Performing Minor Repair on UFTP Shipment**

### **Mechanic Dose Calculation**

A mechanic or tow truck driver may receive dose from the shipment during a minor repair or while fixing a tire. A tire or minor breakdown repair is assumed to be a singular occurrence experienced by a given mechanic. Conservatively, dose rates for peak burnup fuel (see Section 3.2.1) are used in the dose calculations.

#### **Dose received during Tire Repair**

$$\begin{aligned} \text{Dose rate at 0.4 m} &= 0.017 \text{ mSv/h (see NWMO TR-2012-06, Table A-3-1b)} \\ \text{Dose} &= \text{dose rate} \times \text{duration} \\ &= 0.017 \text{ mSv/h} \times 1 \text{ h} \\ &= 0.017 \text{ mSv} \end{aligned}$$

#### **Dose received during Breakdown Repair**

$$\begin{aligned} \text{Dose rate at 1 m} &= 0.0082 \text{ mSv/h (see NWMO TR-2012-06, Table A-3-1b)} \\ \text{Dose} &= \text{dose rate} \times \text{duration} \\ &= 0.0082 \text{ mSv/h} \times 1/2 \text{ h} \\ &= 0.0041 \text{ mSv} \end{aligned}$$

### **Conclusions:**

The radiological dose due to used fuel transportation estimated to be received by a mechanic or tow truck operator is 0.017 mSv, which is less than the regulatory dose limit for the public.

## APPENDIX C: CALCULATION OF DOSE TO INDIVIDUAL DUE TO PASSING UFTP SHIPMENT

Several scenarios identified in this report include a stationary worker exposed to a UFTP shipment as it slowly passes by (i.e., a weigh scale operator). A radiological dose from the shipment is received by the worker during this exposure. This appendix describes the method used to account for the dose received due to the passing shipment.

This appendix provides an estimated exposure of a person standing at a fixed distance ( $l$ ) normal to the transport-truck path going at a constant speed ( $v$ ). The assumptions used in deriving the exposure are listed as follows.

1. The UFTP shipment will not change its travelling speed.
2. The person is stationary and facing perpendicular to the UFTP shipment travel path during the exposure period.
3. The person is located sufficiently far away from the UFTP therefore a point-source approximation can be applied, i.e. using the  $1/r^2$  approximation to estimate dose rates at distance farther than 5 m.
4. The person is on the same elevation as the UFTP; no credit is given to the risen height of the truck bed.
5. No credit is given to any intervening structure between the person and the UFTP shipment; therefore there is no material attenuation other than geometric attenuation.

### C.1 INTEGRATED DOSE AT THE RECEPTOR

Assuming the person standing at P is at a fixed normal distance  $l$  from the travel path of the transport truck (see Figure C-1), the dose rate at location P, defined as  $d(P)$ , is inversely proportional to the distance between the UFTP and the receptor, i.e. distance  $r$ .

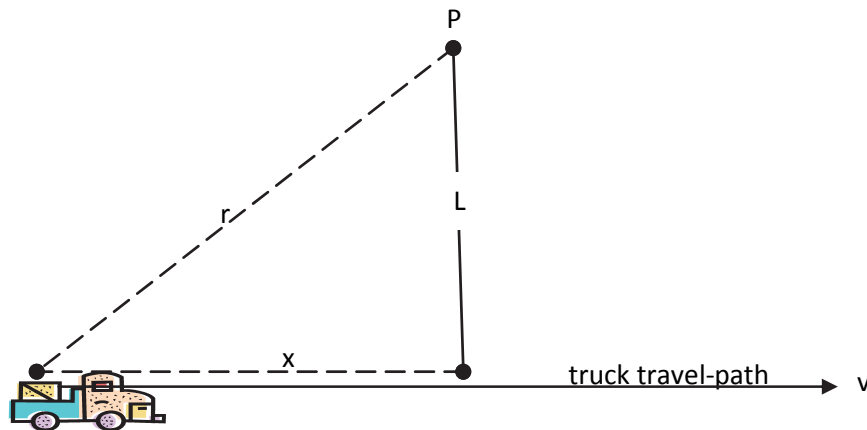

Figure C-1: Schematic of the Receptor Location P to the Travel Path

If  $S$  is defined to be the end-on dose rate at  $h$  metres from the UFTP, then  $d(r)$  at distance  $r$  can be formulated as follows.

$$d(r) = \frac{S \times h^2}{r^2} \quad (C1)$$

or

$$d(r) = \frac{S \times h^2}{(x^2 + l^2)} \quad (C2)$$

where  $x$  is the distance of the UFTP to the plane that is perpendicular to travel-path. Distance  $x$  at time  $t$  for a truck travelling at constant speed  $v$  is defined as

$$x = vt \quad (C3)$$

Therefore the total dose  $D$  at the receptor location  $P$  due to an approaching transport truck carrying 1 UFTP can be calculated by integrating equation C2.

$$D = \int_{-\infty}^{\infty} \frac{S \times h^2}{(vt)^2 + l^2} dt \quad (C4)$$

Since:

$$dx = vdt \quad (C5)$$

equation C4 becomes:

$$D = \int_{-\infty}^{\infty} \frac{S \times h^2}{x^2 + l^2} \frac{dx}{v} \quad (C6)$$

Completing the integration, the total dose  $D$  for a person standing at location  $P$  due to a non-stopping transport truck carrying one UFTP travelling at constant speed  $v$  at a non-varying distance  $L$  normal to the travel path is calculated by the following equation.

$$D = \frac{\pi Sh^2}{3600vl} \quad (C7)$$

The units for  $v$  and  $l$  are in m/s and m respectively. The units for  $D$  and  $S$  are in mSv and mSv/h respectively.



### C.1 DOSE RATE PROFILE AT THE RECEPTOR

Presenting the information in a different format, Table C-1 shows the variation of the dose exposure as a function of truck speed and the separation distance  $l$ . Note that all doses are calculated with no credit given to any intervening structures between the receptor and the truck.

**Table C-1: Integrated Dose at different Truck Speeds and Separating Distances**

Distance $l$ from Receptor to Truck Path, m	Integrated Dose D at Receptor Location P, mSv						
	5 km/h	10 km/h	24 km/h	30 km/h	50 km/h	80 km/h	100 km/h
2 m	3.0E-06	1.5E-06	6.4E-07	5.1E-07	3.0E-07	1.9E-07	1.5E-07
3 m	2.0E-06	1.0E-06	4.2E-07	3.4E-07	2.0E-07	1.3E-07	1.0E-07
10 m	7.0E-07	3.5E-07	1.5E-07	1.2E-07	7.0E-08	4.4E-08	3.5E-08
30 m	2.5E-07	1.2E-07	5.1E-08	4.1E-08	2.5E-08	1.5E-08	1.2E-08



## APPENDIX D: RATIONALE FOR LIMITING SCOPE TO ROAD TRANSPORT

### Assumptions

- Radiological dose due to road transport bounds occupational dose received from road and rail modes of transport

### Data

#### Transport Driver

- Tractor-trailer driver receives highest occupational dose due to road transport
- From Appendix B-5 (highest dose to driver – 0.35 mSv for a 2900 km trip):
  - Annual dose due to driving 0.17 mSv
  - Annual dose due to inspections 0.15 mSv
  - Annual dose due to other activities 0.03 mSv

### Assessment

#### Dose Estimate for Locomotive Engineer:

- Locomotive engineer is responsible for the safe operation of the train from point of origin to destination.
- Train consists of a minimum of five railcars each containing 2 UFTPs, with buffer cars on each end and two locomotives pulling the train (1)
- Only dose rate emitted by from first UFTP on rail car need be considered. Radiation from the UFTPs behind the first must pass through its own shielding plus the shielding and contents of all UFTPs in front of it. It has been shown (2) that radiation from UFTPs behind the first is negligible at the front external face of the first UFTP.
- A typical railcar is assumed to be 15 m long. A typical locomotive (EMD SD40) is assumed to be 21 m long. Together, the buffer car and 2<sup>nd</sup> locomotive would be at least 36 m long.
- The locomotive engineer would be located at least the length of the buffer car and the rear locomotive away from the first UFTP. As this distance is greater than 30 m, (without crediting shielding provided locomotive) the dose to the locomotive engineer during transit would be negligible (see Appendix A).
- As dose due to driving accounts for approximately 50% of a drivers occupational dose and a locomotive engineer would receive negligible dose during this time, it can be concluded that a truck driver will receive a higher occupational dose than a locomotive engineer.

#### Dose Estimate for Intermodal Transfer Worker:

- Intermodal transfer worker is responsible for loading or unloading UFTP onto or from a railcar.
- Loading and unloading will typically take place at a specialized designated facility.
- Only dose rate emitted by from one UFTP on railcar need be considered. Radiation from the UFTPs behind the first must pass through its own shielding plus the shielding and contents of all UFTPs in front of it. It has been shown (2) that radiation from UFTPs behind the first is negligible at the front external face of the first UFTP.
- Most of the loading and unloading operations are anticipated to be automated.
- Transfer is assumed to take 5 minutes during which the worker is assumed to be located an average distance of 2 m from the UFTP for 4 minutes and right beside the UFTP for 1 minute.
- Dose received

### Dose received at 2 m from UFTP

$$\begin{aligned} \text{Dose rate at 2 m} &= 0.0024 \text{ mSv/h (see Figure 4 in main report)} \\ \text{Dose} &= \text{dose rate} \times \text{duration} \\ &= 0.0025 \text{ mSv/h} \times 0.0667 \text{ h} \\ &= 1.62 \times 10^{-4} \text{ mSv} \end{aligned}$$

### Dose received at contact with UFTP

$$\begin{aligned} \text{Dose rate at contact} &= 0.0139 \text{ mSv/h (see Figure B-7-2)} \\ \text{Dose} &= \text{dose rate} \times \text{duration} \\ &= 0.0139 \text{ mSv/h} \times 0.0167 \text{ h} \\ &= 2.32 \times 10^{-4} \text{ mSv} \end{aligned}$$

### Total dose received by intermodal transfer worker during transfer

$$\begin{aligned} \text{Dose} &= \text{dose at 2 m} + \text{dose at contact} \\ &= 1.62 \times 10^{-4} \text{ mSv} + 2.32 \times 10^{-4} \text{ mSv} \\ &= 3.9 \times 10^{-4} \text{ mSv} \end{aligned}$$

Assume worker is present for all 620 transfers during a one year period

### Total dose received by worker

$$\begin{aligned} \text{Dose} &= \text{dose per event} \times \text{events per year} \\ &= 3.9 \times 10^{-4} \text{ mSv} \times 620 \\ &= 0.24 \text{ mSv} \end{aligned}$$

The dose received by the intermodal transfer worker during the transfer is 0.24 mSv which is less than the dose received by a driver.

### Conclusions

The annual dose estimated to be received by a locomotive engineer is negligible. The annual dose to a worker engaged in intermodal operations (loading or unloading UFTP from railcar) is estimated to be 0.24 mSv/y. Both the locomotive engineer and intermodal worker have been calculated to received less dose than a truck driver.

### References

- (1) Nuclear Waste Management Organization. 2013. Preliminary Assessment for Siting a Deep Geological Repository for Canada's Used Nuclear Fuel. The Corporation of the Township of Ignace, Ontario. Findings from Phase One Studies. NWMO Report APM-REP-06144-0009. November 2013.
- (2) Batters, S., K. Tsang and U. Stahmer. 2012. Generic Transportation Dose Assessment. Prepared for the NWMO by AMEC NSS Ltd. NWMO Report Number NWMO TR-2012-06. October 2012.