

Radionuclide Inventory for Reference CANDU Fuel Bundles

NWMO-TR-2020-05

July 2020

K. Heckman, J. Edward

Kinectrics

nwmo

NUCLEAR WASTE
MANAGEMENT
ORGANIZATION

SOCIÉTÉ DE GESTION
DES DÉCHETS
NUCLÉAIRES

Nuclear Waste Management Organization
22 St. Clair Avenue East, 6th Floor
Toronto, Ontario
M4T 2S3
Canada

Tel: 416-934-9814
Web: www.nwmo.ca

Radionuclide Inventory for Reference CANDU Fuel Bundles

NWMO-TR-2020-05

July 2020

K. Heckman, J. Edward
Kinectrics

This report has been prepared under contract to NWMO. The report has been reviewed by NWMO, but the views and conclusions are those of the authors and do not necessarily represent those of the NWMO.

All copyright and intellectual property rights belong to NWMO.

Document History

Title:	Radionuclide Inventory for Reference CANDU Fuel Bundles		
Report Number:	NWMO-TR-2020-05		
Revision:	R000	Date:	July 2020
Kinectrics			
Authored by:	K. Heckman, J. Edward		
Verified by:	G. LeRoy		
Approved by:	I. Cheng		
Nuclear Waste Management Organization			
Reviewed by:	M. Ion		
Accepted by:	P. Gierszewski		

Revision Summary		
Revision Number	Date	Description of Changes/Improvements
R00	2020-07	Initial issue

ABSTRACT

Title: Radionuclide Inventory for Reference CANDU Fuel Bundles
Report No.: NWMO-TR-2020-05
Author(s): K. Heckman, J. Edward
Company: Kinectrics
Date: July 2020

Abstract

This report documents a radionuclide inventory assessment for reference used CANDU fuel bundles. The inventories of radionuclides in used CANDU fuel bundles are important parameters in safety assessments carried out by NWMO. The radionuclide inventories include actinides and fission products in the UO₂ fuel, neutron activated impurities in the UO₂ and Zircaloy cladding, and trace actinides and fission products in the Zircaloy cladding.

Used fuel burnup and (decay) time since discharge are important parameters for inventory. The inventories are therefore presented for varying burnup and decay time.

Screening studies indicated that the radionuclide inventories are not sensitive, on a unit mass basis, to the reactor or bundle type. In particular, the screening studies examining the bundle design (i.e. 28-element, modified 37-element, regular 37-element) showed only small (less than about 5%) differences in radionuclide inventory and associated data per unit mass basis. The reference bundle type was therefore selected as the regular 37-element, which is the most abundant bundle type.

The screening studies examining the effect of bundle power demonstrated differences in the inventories of many radionuclides, though only small (<3%) differences in the integrated quantities. Results are presented here at a median power level, selected as 720 kW bundle power, which represents the highest median bundle power rating of fuel bundles at all Canadian CANDU reactors of any decade.

The total radionuclide inventory and thermal power are presented here as a function of decay time for a reference bundle at 220 MWh/kgU burnup, which represents the highest median burnup of fuel at all Canadian CANDU reactors of any decade. In addition, the data are presented for a burnup of 290 MWh/kgU, which represents the highest 95th percentile burnup of any decade.

This page is intentionally left blank.

TABLE OF CONTENTS

	Page
ABSTRACT	iii
1. INTRODUCTION.....	viii
1.1 Previous Reference Inventory.....	1
2. SOFTWARE QUALITY ASSURANCE AND METHODOLOGY	2
2.1 Code Version and Libraries Used.....	2
2.2 Methodology	3
2.2.1 Generating the Burn-Up Dependent Neutron Cross Section Libraries.....	3
2.2.2 ORIGEN Inventory Calculations.....	4
3. CANDU FUEL PROPERTIES	6
3.1 Design and Dimensions	9
3.1.1 28-Element Fuel	9
3.1.2 Regular and Modified 37-Element Fuel (Standard and Long).....	11
3.2 Composition.....	13
4. CANDU FUEL BURNUP DISTRIBUTION.....	19
5. SCREENING OF RADIONUCLIDES FOR SELECTION OF THE REFERENCE FUEL	21
5.1 Process.....	21
5.2 Selected Radionuclides.....	21
6. REGRESSION TESTING COMPARISONS WITH TAIT ET AL. (2000) INVENTORIES	23
7. REFERENCE FUEL BUNDLE SCREENING STUDY	25
7.1 Bundle Design.....	26
7.1.1 28-Element Bundle vs Regular 37-Element Bundle.....	26
7.1.2 Modified 37-Element Bundle vs Regular 37-Element Bundle	26
7.1.3 Bundle Length (Standard vs Long).....	27
7.2 Power Dependence.....	27
7.2.1 Fuel Inventory	27
7.2.2 Thermal Power	28
7.2.3 Gamma Power	28
7.2.4 Neutron Power.....	28
7.3 Selection of a Reference Fuel	28
8. CALCULATIONS OF RADIONUCLIDE INVENTORY FOR USED NUCLEAR FUEL USING THE ORIGEN-S CODE	30
9. SUMMARY	31
REFERENCES	32

APPENDIX A: RESULTS OF THE ORIGEN-S RADIONUCLIDE SCREENING STUDIES.....	34
APPENDIX B: REGRESSION TESTING COMPARISON RESULTS	43
APPENDIX C: BUNDLE SCREENING STUDY COMPARISONS.....	45
APPENDIX D: RADIONUCLIDE HALF-LIVES	55
APPENDIX E: RADIONUCLIDE INVENTORIES FOR THE REFERENCE FUEL.....	58

LIST OF TABLES

	Page
Table 1: Summary of Inventory by Bundle Type as of June 2019 (Gobien and Ion 2019)	9
Table 2: Abundances of Radionuclides in Natural Uranium (Meija 2016a, 2016b)	9
Table 3: Pickering 28-Element Fuel Bundle Nominal Dimensional Data.....	10
Table 4: Bruce and Darlington 37-Element Fuel Bundle Nominal Dimensional Data	12
Table 5: Composition of Uranium Dioxide Fuel	14
Table 6: Composition of Overall Zircaloy (Including Tubing, End Plate, End Cap, Braze, Spacer and CANLUB)	16
Table 7: Maximum, Median, and Percentiles for Burnups and Power Ratings of Discharged Fuel from Canadian Power Reactors (Wilk 2013).....	20
Table 8: Nuclides and Elements Important to Dose as Indicated by NWMO	35
Table 9: Radionuclides Contributing at least 0.1% of Gamma Power in Fuel at Each Decay Period.....	36
Table 10: Radionuclides Contributing at least 0.1% of Neutron Intensity in Fuel at Each Decay Period.....	37
Table 11: Radionuclides Contributing at least 0.1% of Thermal Power in Fuel at Each Decay Period.....	38
Table 12: Consolidated List of Significant Radionuclides in Fuel per Decay Period (GREEN: selected as a top contributor to gamma power, neutron intensity or thermal power, YELLOW: selected as important to dose only)	39
Table 13: Light Element Radionuclides Contributing at least 0.1% of Gamma Power in Zircaloy at Each Decay Period.....	42
Table 14: Radionuclides Contributing at least 0.1% of Thermal Power in Zircaloy at Each Decay Period.....	42
Table 15: Comparison of Total Activity, Thermal Power, Gamma Power, Gamma Emissions, and Neutron Intensity in Fuel to Tait et al. (2000) Results	43
Table 16: Comparison of Total Activity, Thermal Power, Gamma Power and Intensity of Light Elements in Cladding to Tait et al. (2000) Results	44
Table 17: Bundle Screening Study – 28-element Relative to 37R Significant Radionuclide Mass per kg U (200 kW, 230 MWh/kgU).....	45
Table 18: Bundle Screening Study – 28-element Relative to 37R Significant Element Mass per kg U (200 kW, 230 MWh/kgU).....	48
Table 19: Bundle Type Screening Study – Comparison of Total Thermal Power per kg U in Different Bundle Types relative to 37R Bundle (200 kW, 230 MWh/kgU).....	49
Table 20: Bundle Type Screening Study – Comparison of Total Gamma Power per kg U in Different Bundle Types Relative to 37R Bundle (200 kW, 230 MWh/kgU)	49
Table 21: Bundle Type Screening Study – Comparison of Total Neutron Power per kg U in Different Bundle Types Relative to 37R Bundle (200 kW, 230 MWh/kgU)	49
Table 22: Bundle Type Screening Study – 37M Relative to 37R Significant Radionuclide Mass per kg U (200 kW, 230 MWh/kgU).....	50
Table 23: Bundle Type Screening Study – 37M Relative to 37R Significant Element Mass per kg U (200 kW, 230 MWh/kgU).....	53
Table 24: Actinide Half-Lives.....	55
Table 25: Fission Product Half-Lives.....	56
Table 26: Light Element Half-Lives.....	57
Table 27: UO ₂ Fuel - Total Radionuclide Activity (Bq/Initial kg U), 220 MWh/kgU, 720 kW/bundle.....	59

Table 28: Zircaloy Cladding - Total Radionuclide Activity (Bq/Initial kg Zr), 220 MWh/kgU, 720 kW/bundle.....	69
Table 29: Total Thermal Power for UO ₂ Fuel and Zircaloy Cladding, 220 MWh/kgU, 720 kW/bundle.....	80
Table 30: UO ₂ Fuel - Total Radionuclide Activity (Bq/Initial kg U), 290 MWh/kgU, 720 kW/bundle.....	81
Table 31: Zircaloy Cladding - Total Radionuclide Activity (Bq/Initial kg Zr), 290 MWh/kgU, 720 kW/bundle.....	91
Table 32: Total Thermal Power for UO ₂ Fuel and Zircaloy Cladding, 290 MWh/kgU, 720 W/bundle.....	102

LIST OF FIGURES

	Page
Figure 1: Pickering Fuel Bundle Design (from Wasywich (1993), Tait et al. (2000))	7
Figure 2: Bruce and Darlington Standard Fuel Bundle Design (from Wasywich (1993), Tait et al. (2000))	8

1. INTRODUCTION

The Nuclear Waste Management Organization (NWMO) was established in 2002 under the Nuclear Fuel Waste Act to assume responsibility for the safe, long-term management of Canada's used nuclear fuel.

The inventories of radionuclides and other potential contaminants in used CANDU fuel, and the radiation fields coming from the used fuel, are important parameters in the safety assessments. The radionuclide inventories include actinides and fission products in the UO_2 fuel, neutron activated impurities in the UO_2 and Zircaloy cladding, and trace actinides and fission products in the Zircaloy cladding.

Ontario Power Generation (OPG) produced a compilation of CANDU radionuclide inventory data in 2000 (Tait et al. 2000, 2001). This report provides an updated analysis of isotope abundances and other related information for used CANDU fuel bundles using the most recent Industry Standard Tool (IST) version of the ORIGEN-S code (version 6.1.3) and the latest CANDU bundle specific nuclear data (e.g. cross-sections, decay data, fission product yields).

Specifically, this report documents a comparison of the updated radionuclide inventory assessment with the original compilation in Tait et al. (2000), provides updates to the fuel data collection presented in Tait et al. (2000), and presents the results from screening studies for the selection of a reference CANDU fuel bundle. The objective of the screening studies is to propose a reference fuel bundle that conservatively represents the fuel bundles used at Pickering, Bruce, Darlington, Point Lepreau and Gentilly-2 (i.e. considering differences in fuel power ratings and bundle designs).

1.1 PREVIOUS REFERENCE INVENTORY

The previous reference inventory is documented in Tait et al. (2000, 2001). The UO_2 and Zircaloy composition were estimated from maximum allowable concentrations in manufacturing and material specifications or analytical data where available. The alloy elements of the cladding, as well as the beryllium braze and CANLUB coating were also considered.

A screening process examined the impact on the radionuclides of most interest with respect to the following fuel parameters:

1. Bundle design (37-element vs 28-element),
2. Bundle length (Bruce long vs. Bruce standard),
3. Fuel power,
4. Burnup, and
5. The use of an average bundle burnup vs. accounting for the burnup of individual elements.

A standard 37-element bundle at a reference burnup of 220 MWh/kgU and a power of 455 kW/bundle was selected as the reference fuel bundle based on the screening studies performed.

Radionuclide inventories and radiation emission properties for the reference fuel bundle were calculated using the ORIGEN-S version SCALE 4.2 code with a burnup-dependent library for the 37-element fuel bundle (Gauld et al. 1995a, 1995b). Burnup-dependent CANDU cross-sections were compiled from two sources:

1. an AMPX format ENDF/B IV 27-group neutron library used in SCALE 4.2, which included the following nuclear data:
 - a) Nuclear decay data from ENDF/B-VI and ENSDF,
 - b) Fission product yields from ENDF/B-V,
 - c) Energy release from ENDF/B-VI, and
 - d) Neutron cross-sections from ENDF/B-IV, ENDF/B-V, and ENDF/B-VI
2. the WIMS-AECL 89-group library.

Separate radionuclide and element inventories were produced for the UO₂ fuel and for the Zircaloy used as cladding material. The radionuclide inventories for the fuel were obtained by irradiating the UO₂ and its impurities. The radionuclide inventories resulting from activation of the cladding were calculated by assuming a matrix of 1 kg of Zircaloy with impurities together with 1 kg of Uranium, with the same fission power and burnup as the Uranium in the fuel. Only the activation products were reported for the Zircaloy inventory.

Radionuclide inventories were calculated for three burnups: 220 MWh/kgU, 280 MWh/kgU, and a high burnup case of 320 MWh/kgU.

Since this reference inventory was published, there have been significant developments in the ORIGEN-S code, revisions to the nuclear data libraries, and a new fuel type (the modified 37-element fuel bundle) has been used at several reactors. These changes, together with a change in the approach to simulating the irradiation of the cladding, are presented in the subsequent sections of this report.

2. SOFTWARE QUALITY ASSURANCE AND METHODOLOGY

2.1 CODE VERSION AND LIBRARIES USED

The CANDU Industry Standard Tool (IST) code SCALE Version 6.1.3 is used in the current analysis. The relevant portions of the SCALE 6.1.3 package, include MCDANCOFF, TRITON, COUPLE, OPUS, and ORIGEN. This set of codes is referred to below as SCALE 6.1.3.

Burnup-dependent neutron cross-section libraries based on both ENDF/B-VII.0 (Chadwick et al. 2006) and JEFF-3.0/A (Sublet et al. 2003) are developed for different CANDU bundle types using the MCDANCOFF and TRITON modules of the SCALE 6.1.3 code package. Decay data is based on ENDF/B-VII.1 (Chadwick et al. 2011). The development of the burnup-dependent neutron cross-section libraries is discussed in Section 2.2.1.

As described in the SCALE 6.1 User Manual (ORNL 2011, Section F7.1), the ORIGEN code was developed to address the following:

“The ORIGEN (Oak Ridge Isotope Generation) code was developed at Oak Ridge National Laboratory (ORNL) to calculate nuclide compositions and radioactivity of fission products, activation products, and products of heavy metal transmutation. ORIGEN

analyzes the full isotopic transition matrix through application of the matrix exponential method to solve the rate equations that describe the nuclide generation, depletion, and decay processes.”

SCALE 6.1.3 has been qualified for updating used fuel isotope inventories in accordance with internal Kinectrics procedures that are compliant with CSA N286.7-99, and N286.7.1-09. SCALE 6.1.3 has seen frequent use at Kinectrics in calculations in support of safety analysis, environmental qualification, dry fuel storage, and many other applications.

2.2 METHODOLOGY

2.2.1 Generating the Burn-Up Dependent Neutron Cross Section Libraries

2.2.1.1 MCDANCOFF Factors

To account for the heterogeneous effects of a lattice of fuel rods/pins, a Dancoff factor is applied to the neutron leakage probability from individual pins. The Dancoff factor is the probability that a neutron emitted from the surface of one fuel pin, or "lump", will pass un-collided through the external medium and enter another pin where it will be absorbed. Dancoff factors are important input parameters for CENTRM (Williams and Hollenbach 2011), the 1-D discrete ordinates code in the SCALE 6.1 (ORNL 2011) suite, that is used for resonance self-shielding calculations in the preparation of macroscopic problem dependent cross-section libraries for ORIGEN-S.

The MCDANCOFF module (Petrie and Rearden 2011) of SCALE 6.1.3 can be used to calculate Dancoff factors in complicated, three-dimensional (3-D) CANDU geometries using Monte Carlo method. Multiple Dancoff factors, representative for each fuel ring of the bundle, can be calculated with one input file that describes the whole fuel bundle.

Input files for 28-element, 37-element ("37R") and modified 37-element ("37M") CANDU fuel are developed according to the MCDANCOFF user manual (Petrie and Rearden 2011) using the fuel bundle properties and geometries described in Section 3 of this report.

2.2.1.2 TRITON Burnup-Dependent Cross-Section Data Libraries Generation

TRITON (Jesse and DeHart 2011) is the primary lattice physics module of the SCALE (ORNL 2011) code system. It generates ring specific and bundle average cross-section libraries for further use in ORIGEN-S. Due to a known issue in the CANDU bundle-average libraries in this version of SCALE, and for slightly greater accuracy, TRITON is only used to generate ring-specific cross-sections, which are then combined into bundle averages.

The collapsing of the neutron cross-sections is performed using the neutron flux calculated with the NEWT functional module, which performs two-dimensional (2-D) transport and depletion calculations (Jesse and DeHart 2011).

In comparison, the burnup dependent neutron cross-section libraries for CANDU fuel that are distributed with SCALE 6.1.3 and previous versions of the package (Gauld et al. 1995a, 1995b) were generated with cross sections from a variety of different sources: capture and fission cross sections were obtained from collapsed 89-group ENDF/B-V and -VI data from the WIMS-AECL lattice code. The WIMS lattice cell models used for the 89-group neutron flux

generation contain one fuel material assigned to all fuel rings. Other reaction cross sections were obtained from the SCALE 27-group ENDF/B-IV data.

TRITON input files for 28-element, regular 37-element, and modified 37-element CANDU fuel bundles were developed using ring specific fuel materials according to the TRITON user manual (Jesse and DeHart 2011). They are consistent with the MCDANCOFF bundle models and use the fuel bundle properties described in Section 3 of this report.

2.2.2 ORIGEN Inventory Calculations

Nuclide inventories for different CANDU bundles are generated using the ORIGEN module of SCALE 6.1.3 together with the TRITON-generated burnup-dependent cross-section data libraries.

Separate code runs are performed using the ring specific libraries for each fuel ring. The bundle-average results are determined using the mass of a single element in the corresponding ring and then combined based on the number of elements in each ring. To obtain the inventory results on a per kg U (initial Uranium) basis, the combined results for all rings are divided by the bundle Uranium mass.

Inventory calculations are performed for the following sets of input:

- Fuel bundle types: 28, 37R, and 37M
- Burnups: 220, 230, 250, 290, and 320 MWh/kg(U)
- Bundle fission power: 200, 455, 720, 860, and 900 kW
- Decay times: 0, 5, 10, 15, 20, 30, 40, 50, 70, 100, 200, 300, 500, 1000, 10^4 , 10^5 , 10^6 and 10^7 years

Separate inventory calculations are performed for fuel (with impurities) and for fuel plus cladding (with impurities in both). For the fuel plus cladding calculations, the amount of cladding included is representative of the ratio of cladding to fuel in the bundles. The results for the cladding alone are then obtained by subtracting the results for the fuel (with impurities) from the results for the fuel plus cladding (with impurities in both).

Since traces of actinides are included in the cladding, this method results in the fuel plus cladding cases being irradiated with a slightly different flux than the fuel only case. The impact of this discrepancy is within the uncertainty of the calculations for the light element activation products. However, the underestimate in the total burnup of the fuel in the combined case potentially underestimates the fission products and actinides in the cladding when the results of the fuel only case are subtracted. Therefore a different approach is used here to estimate the fission product and actinide radionuclides in the cladding.

As presented in Section 3.2, the concentration of Uranium in the cladding material is 46 ppm. In 2 kg of Zircaloy cladding, there would be 9.2×10^{-5} kg of Uranium. This is not a significant amount compared to the 19.25 kg of Uranium in a standard 37-element bundle and would be lower than the limits of precision with which SCALE 6.1.3 outputs results. Thus, tracking the impact of fission of trace Uranium on radionuclide inventories and integrated properties (e.g., photon energy spectra and thermal power) by means of differences between the output for fuel plus clad and fuel alone results in an impractical case of very small differences between large numbers. Therefore, only the light element activation product results for the cladding are

obtained using the approach described above. Results for fission products and actinides in the cladding are instead prorated from the results of the fuel only calculations.

This approach for the calculation of the cladding inventories differs from the previous analysis reported in Tait et al. (2000). The cladding analysis reported in Tait et al. (2000) used a 1:1 weight ratio for Zircaloy:U, which is less realistic. The previous analysis also did not include any actinides in the cladding impurities, (whereas the current analysis includes Uranium, Thorium, and Protactinium as cladding impurities), and therefore only reported the light element activation products in the Zircaloy.

The bundle averaged results of the SCALE 6.1.3 calculations are reported for fuel on a per kg U (initial Uranium) basis for the light elements, fission products, actinides, and total, for inventory and spectra results. The bundle averaged results for the cladding on a per kg Zircaloy basis for light elements are also reported for the same groups of data identified below (where appropriate). Pro-rated results for fission products and actinides in the cladding are post-processed using the fuel results and presented on a per kg Zircaloy basis for these groups as well.

3. CANDU FUEL PROPERTIES

The dimensional and compositional data relevant to the inventory of used CANDU fuel are taken from the OPG report for Pickering, Bruce and Darlington CANDU fuels Tait et al. (2000). This report provides the following concise summary of the CANDU fuel bundles:

All CANDU fuel bundles are fabricated from natural UO_2 pellets that are contained in a Zirconium-alloy (Zircaloy-4) tube (cladding). The Zircaloy-4 cladding (herein after referred to as Zircaloy) contains the alloy elements tin, iron, chromium and sometimes nickel. In addition, beryllium is used as a braze alloy to attach the appendages to the fuel cladding (i.e. bearing pads, inter-element spacers) and CANLUB, a commercial graphite coating, is applied to the inner surface of some fuel elements. The fuel elements are assembled into three basic designs: the 28-element bundle used in the Pickering reactors, the 37-element (standard) bundle used in the Bruce and Darlington reactors, and a 37-element (long) bundle that is also used in the Bruce B and Darlington reactors.

The diagrams of the Pickering 28-element and standard Bruce/Darlington 37-element bundle with nominal dimensional information, as provided in Tait et al. (2000), are reproduced here as Figure 1 and Figure 2.

Since the Tait et al. (2000) compilation was produced, Darlington Nuclear Generating Station and Bruce Nuclear Generating Station have started to use the new fuel bundle design known as the modified 37-element fuel bundle ("37 M"). The primary difference between the regular 37-element and the modified 37-element fuel bundles is the reduction in the outer diameter of the central fuel element together with a reduced sheath thickness for the central fuel element.

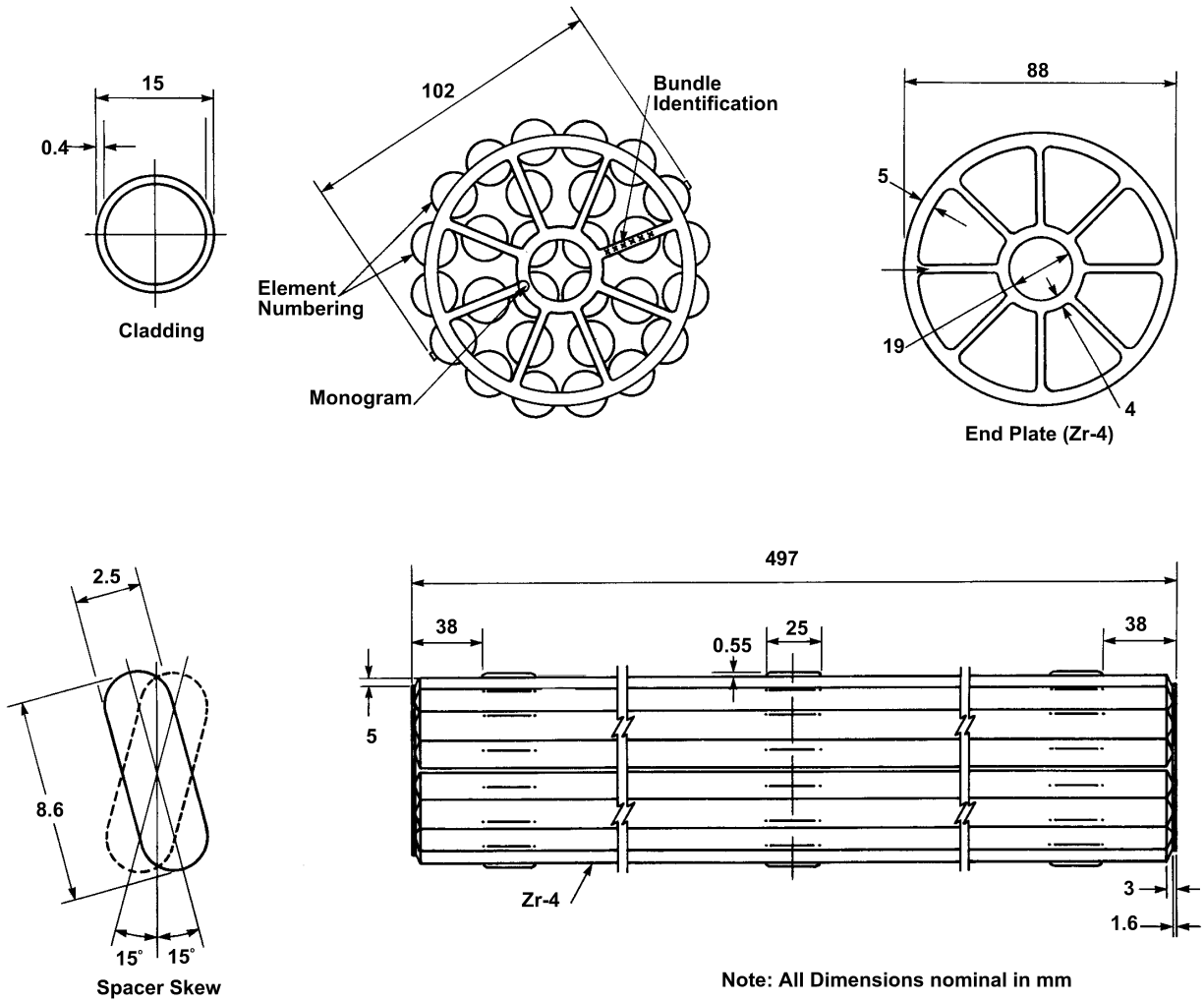

Figure 1: Pickering Fuel Bundle Design (from Wasywich (1993), Tait et al. (2000))

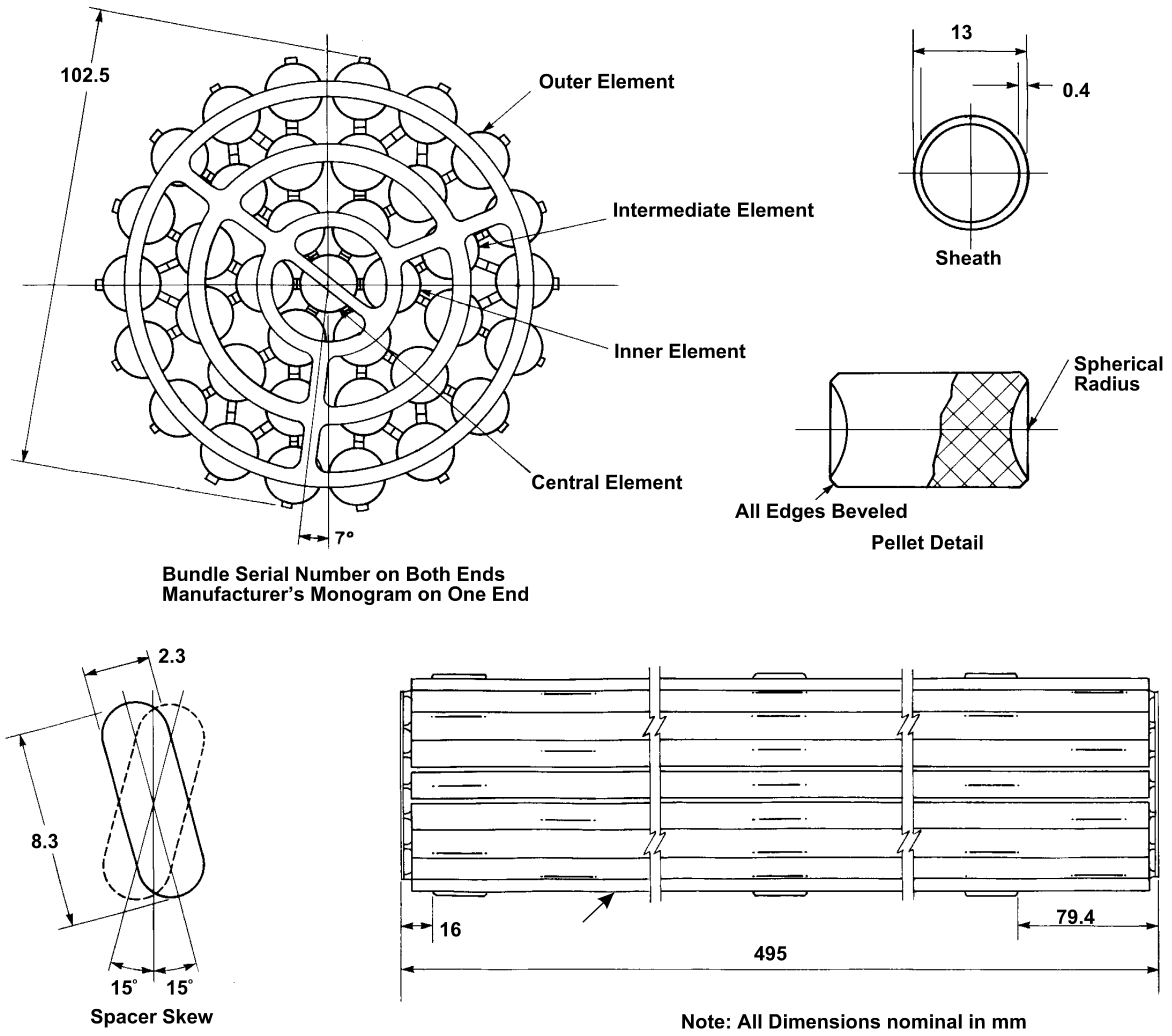

Figure 2: Bruce and Darlington Standard Fuel Bundle Design (from Wasywich (1993), Tait et al. (2000))

A summary of the existing and forecast inventory of used nuclear fuel wastes in Canada is provided in Gobien and Ion (2019). Table 1 below summarizes the existing inventories as of June 2019. The overall projected nuclear fuel waste from existing reactors, based on the current or planned reactors and refurbishments, is about 5.5 million bundles, of which about 16% are 28-element bundles and about 83% are 37-element bundles (Gobien and Ion 2019).

Table 1: Summary of Inventory by Bundle Type as of June 2019 (Gobien and Ion 2019)

CANDU Bundle Type	Where Used	Current Total (# bundles)
18 Element	Gentilly 1, Whiteshell	4,417
19 Element	NPD, Douglas Point	26,296
28 Element	Pickering	773,335
37 R	Bruce, Darlington, Gentilly 2, Pt Lepreau	1,619,288
37 R Long	Bruce, Darlington	236,016
37 M	Bruce, Darlington	201,601
37 M Long	Darlington	72,002
Other	Various (AECL, other)	1,967
TOTAL		2,934,922

3.1 DESIGN AND DIMENSIONS

The abundances of natural uranium as outlined in Table 2 were used for all analyses.

Table 2: Abundances of Radionuclides in Natural Uranium (Meija 2016a, 2016b)

	U-234	U-235	U-238
atom %	0.0054%	0.7204%	99.2742%

3.1.1 28-Element Fuel

The Pickering A and B reactors have used 28-element CANDU fuel bundles. The detailed dimensional and material data for the 28-element fuel bundles are provided in Figure 1 and Table 3 (both reproduced from Tait et al. 2000). The data in Table 3 has been updated to reflect the dimensions used in the current analysis where noted. In earlier Pickering bundles, only the 16 outer elements were coated with CANLUB, but later all surfaces were coated. For this report, it was assumed that all elements are coated with CANLUB.

Table 3: Pickering 28-Element Fuel Bundle Nominal Dimensional Data

Bundle Component	Property^a
Fissionable material	natural UO ₂
Structural Material (cladding, end plates, bearing and spacer pads)	Zircaloy-4
UO₂ Pellet	
Outside diameter (mm)	14.3
Length (mm)	18 (varies)
Dish depth, (mm)	0.2
Stack length (mm)	481
Average density (Mg/m ³)	10.23
Note: A value of 10.23 g/cm ³ is used in MCDANCOFF and TRITON calculations; this is a prorated value to account for the difference between the pellet stack length (48.10 cm) and the bundle length (49.53 cm).	
Number per element (variable)	26
End Plate	
Diameter (mm)	88.4
Thickness (mm)	1.6
Cladding	
Average outside diameter (mm)	15.2
Average wall thickness (mm)	0.4
Length (mm)	485
Density (Mg/m ³)	7.26
Note: A value of 7.26 g/cm ³ is assumed for the density of the Zircaloy-4 in the cladding in the lattice calculations to account for the mass of the end-cap.	
Number elements with CANLUB	28
Bearing Pads	
Length overall (mm)	32
Width (mm)	2.5
Height (mm)	1.0 or 1.2
Spacer Pads	
Length (mm)	8.65
Width (mm)	2.5
Height (mm)	0.55 to 2.50
Bundle Assembly	
Maximum diameter (mm)	102.5
Length (mm)	497.1
Material Mass per Bundle	
Bundle mass (kg)	24.8
UO ₂ (initial kg)	22.8
U (initial kg)	20.1

Bundle Component	Property^a
Total Zircaloy (kg)	2
- End caps (g)	214
- Cladding (kg)	1.7
- End plates (g)	52
- Spacer pads (g)	11
- Bearing pads (g)	28
Material Volumes per Bundle (cm³)	
UO ₂	2140
Zircaloy (total)	300
Cladding	260
End Plates	8
Spacing pads	2
Bearing pads	4

Note:

- a. All data are from Tait et al (2000), unless noted otherwise.

3.1.2 Regular and Modified 37-Element Fuel (Standard and Long)

Regular and modified 37-element fuel bundles are used in the Bruce and Darlington reactors. Both Bruce and Darlington use standard and long bundles. Regular 37-element bundles are also used in the CANDU 6 utilities (NB Power and Hydro Quebec).

There are at least three specifications for regular CANDU 37-element fuel bundles, respectively for Bruce Power, OPG, and the CANDU 6 utilities. A review of the information available for these three sources indicates that the specifications give a small range for most parameters, and that the values selected for the TRITON model lie within the ranges for all three sources.

A modified 37-element bundle design (37M) is now in service. The primary difference is the smaller dimension of the central element. These bundles are also available in standard and long lengths.

The dimensional and materials data for the regular 37-element fuel bundles, including the differences in the long bundles are provided in Figure 2 and Table 4 (both reproduced from Tait et al. 2000). Some of the data in Table 4 has been updated to reflect the dimensions used in the current analysis where noted. Note that the dimensions of the 37M bundles are proprietary and not listed. In cases where no data is provided for the long element, the standard element dimensions are used in the assessment.

Table 4: Bruce and Darlington 37-Element Fuel Bundle Nominal Dimensional Data

Bundle Component	Standard Element^a	Long Element^a
Fissionable Material	natural-UO ₂	
Structural Material (cladding, end plates, bearing and spacer pads)	Zircaloy-4	
UO₂ Pellet		
Outside diameter (mm)	12.2	
Length (mm)	16 (varies)	
Dish depth (mm)	0.2	
Stack length (mm)	481	493
Average density (Mg/m ³)	10.20	
Note: A value of 10.2 g/cm ³ is used in MCDANCOFF and TRITON calculations; this is a prorated value to account for the difference between the stack length and the bundle length.		
Number per element (variable)	31	
End Plate		
Diameter (mm)	91	
Thickness (mm)	1.6	
Cladding		
Average outside diameter, (mm)	13.1	
Average wall thickness, (mm)	0.4	
Length (mm)	486	499
Density (Mg/m ³)	7.17	
Note: A value of 7.17 g/cm ³ is assumed for the density of the Zircaloy-4 in the cladding in the lattice calculations to account for the mass of the end-cap.		
Number of elements with CANLUB coating	All may be coated	
Bearing pads		
	54/bundle	
Length overall (mm)	32	
Width (mm)	2.5	
Height (mm)	1.0 to 1.2	
Spacer pads		
	156/bundle	
Length (mm)	8.65	
Width (mm)	2.5	
Height (mm)	0.7 to 1.9	
Bundle Assembly		
Maximum diameter (mm)	102.5	
Length (mm)	495	508
Material Mass per Bundle		
Total bundle mass (kg)	24	24.6
UO ₂ (initial kg)	21.7	22.3
U (initial kg)	19.2	19.7

Bundle Component	Standard Element^a	Long Element^a
Total Zircaloy (kg)	2.2	2.24
- Cladding (kg)	1.9	2
- End caps (g)	206	
- End plates (g)	55	
- Spacers (g)	22	
- Bearing pads (g)	33	
Total bundle mass (kg)	24	24.6
Material Volumes per Bundle (cm ³)		
UO ₂	2040	2090
Zircaloy (total)	340	340
- Cladding	290	298
- End plates	8	
- Spacers	3	
- Bearing pads	5	
Cross-sectional area (mid-plane) (mm ²)		
UO ₂	4290	
Cladding only	620	
Cladding (bundle)	1090	
Coolant (neglecting appendages)	3480	

Notes:

- a. All data are from Tait et al (2000), unless noted otherwise.

3.2 COMPOSITION

For the purposes of calculating the Dancoff factors and building the TRITON models used to generate cross-section libraries for each fuel bundle, compositions of Zircaloy-2, Zircaloy-4 and Zr-2.5Nb obtained from the data from prominent suppliers are used (ATI 2017).

The ORIGEN-S radionuclide inventory assessment is then performed using the recommended elemental impurity concentrations as identified in Table 2 of Liberda et al. (2019) for the Fuel (UO₂), and Table 3 of Liberda et al. (2019) for the Overall Zircaloy (including cladding, end plate, end cap, braze, spacer and CANLUB), reproduced here in Table 5 and Table 6. The data was normalized to kg U (initial Uranium) or kg Zircaloy as appropriate.

Table 5: Composition of Uranium Dioxide Fuel

Element	Recommended Value [$\mu\text{g/g}$]	Basis^a
Ag	0.33	Measured data
Al	22	Technical Specification
Ar	1	Assume a value of 1
As	2.1	Measured data
At	1	Assume a value of 1
Au	0.099	Measured data
B	0.26	Technical Specification
Ba	0.1	Measured data
Be	0.3	Measured data
Bi	1.1	Measured data
Br	10	Assume a value of 10
C	180	Technical Specification
Ca	44	Technical Specification
Cd	0.18	Technical Specification
Ce	0.13	Measured data
Cl	4.4	Tait and Johnson (1997)
Co	0.25	Measured data
Cr	13	Technical Specification
Cs	0.3	Measured data
Cu	8.8	Technical Specification
Dy	0.13	Technical Specification
Er	0.031	Measured data
Eu	0.02	Measured data
F	26	Technical Specification
Fe	66	Technical Specification
Ga	0.2	Measured data
Gd	0.088	Technical Specification
Ge	0.064	Measured data
H	1	Assume a value of 1
He	1	Assume a value of 1
Hf	0.29	Measured data
Hg	0.41	Measured data
Ho	0.022	Measured data
I	1	Assume a value of 1
In	1	Assume a value of 1
Ir	0.058	Measured data
K	18	Technical Specification
Kr	1	Assume a value of 1
La	0.1	Measured data

Element	Recommended Value [$\mu\text{g/g}$]	Basis^a
Li	0.46	Measured data
Lu	0.2	Measured data
Mg	8.8	Technical Specification
Mn	4.4	Technical Specification
Mo	1.8	Technical Specification
N	13	Tait and Johnson (1997)
Na	44	Measured data
Nb	0.98	Measured data
Nd	0.039	Measured data
Ne	1	Assume a value of 1
Ni	18	Technical Specification
O	120000	Stoichiometric Value
Os	1	Assume a value of 1
P	31	Technical Specification
Pa	1	Assume a value of 1
Pb	0.77	Measured data
Pd	0.2	Measured data
Pm	1	Assume a value of 1
Pr	0.065	Measured data
Pt	0.2	Measured data
Rb	0.5	Measured data
Re	0.028	Measured data
Rh	0.021	Measured data
Ru	0.04	Measured data
S	11	Measured data
Sb	0.18	Measured data
Sc	0.46	Measured data
Se	2	Measured data
Si	26	Technical Specification
Sm	0.047	Measured data
Sn	0.98	Measured data
Sr	0.2	Measured data
Ta	0.42	Measured data
Tb	1	Assume a value of 1
Te	0.93	Measured data
Th	440	Technical Specification
Ti	0.69	Measured data
Tl	1	Measured data
Tm	0.03	Measured data
U	890000	Measured data

Element	Recommended Value [$\mu\text{g/g}$]	Basis ^a
V	1.3	Measured data
W	1.7	Measured data
Xe	1	Assume a value of 1
Y	1	Assume a value of 1
Yb	0.039	Measured data
Zn	12	Measured data
Zr	3.9	Measured data

Note:

- a. All data are from Liberda et al. (2019), with exception of Br, O, and U, which are slightly different values based on a draft version of Liberda et al. (2019).

Table 6: Composition of Overall Zircaloy (Including Tubing, End Plate, End Cap, Braze, Spacer and CANLUB)

Element	Recommended Value [$\mu\text{g/g}$]	Basis ^{a,b}
Ag	4	Calculated
Al	84	Calculated
Ar	0.1	Assume a value of 0.1
As	0.74	Calculated
At	0.1	Assume a value of 0.1
Au	0.25	Calculated
B	1.8	Calculated
Ba	0.58	Calculated
Be	110	Calculated
Bi	0.38	Calculated
Br	0.008	Calculated
C	5600	Calculated
Ca	28	Calculated
Cd	0.81	Calculated
Ce	0.1	Calculated
Cl	22	Calculated
Co	18	Calculated
Cr	1300	Calculated
Cs	0.24	Calculated
Cu	77	Calculated
Dy	0.43	Calculated
Er	0.01	Calculated
Eu	0.15	Calculated
F	0.33	Calculated
Fe	2400	Calculated

Element	Recommended Value [µg/g]	Basis^{a,b}
Ga	0.53	Calculated
Gd	1.2	Calculated
Ge	0.061	Calculated
H	25	Calculated
He	0.1	Assume a value of 0.1
Hf	100	Calculated
Hg	0.2	Calculated
Ho	0.1	Assume a value of 0.1
I	0.27	Calculated
In	0.08	Calculated
Ir	0.18	Calculated
K	12	Calculated
Kr	0.1	Assume a value of 0.1
La	0.08	Calculated
Li	0.47	Calculated
Lu	0.37	Calculated
Mg	18	Calculated
Mn	45	Calculated
Mo	44	Calculated
N	80	Calculated
Na	20	Calculated
Nb	110	Calculated
Nd	0.037	Calculated
Ne	0.1	Assume a value of 0.1
Ni	460	Calculated
O	1600	Calculated
Os	0.1	Assume a value of 0.1
P	17	Calculated
Pa	0.1	Assume a value of 0.1
Pb	110	Calculated
Pd	5.5	Calculated
Pm	0.1	Assume a value of 0.1
Pr	0.02	Calculated
Pt	1.4	Calculated
Rb	0.18	Calculated
Re	0.026	Calculated
Rh	0.018	Calculated
Ru	0.038	Calculated
S	52	Calculated
Sb	2.1	Calculated
Sc	5.5	Calculated

Element	Recommended Value [$\mu\text{g/g}$]	Basis ^{a,b}
Se	0.89	Calculated
Si	110	Calculated
Sm	0.02	Calculated
Sn	17000	Calculated
Sr	0.3	Calculated
Ta	170	Calculated
Tb	0.1	Assume a value of 0.1
Te	10	Calculated
Th	0.08	Calculated
Ti	46	Calculated
Tl	0.1	Calculated
Tm	0.035	Calculated
U	46 ^c	Calculated
V	43	Calculated
W	87	Calculated
Xe	0.1	Assume a value of 0.1
Y	0.04	Calculated
Yb	0.013	Calculated
Zn	39	Calculated
Zr	980000	Calculated

Notes:

- All data are from Liberda et al. (2019), with exception of Zr which is based on a draft version of Liberda et al. (2019).
- Calculated means mass-weighted sum of measured values and technical specification limits for cladding, end cap, end ring, spacers, braze and CANLUB.
- U value may reflect surface contamination from contact with UO₂ pellets.

4. CANDU FUEL BURNUP DISTRIBUTION

An analysis of the burnups and maximum powers of Canadian used fuel bundles is provided in Wilk (2013). Based on Table 2 of Wilk (2013), reproduced here as Table 7 with values rounded to the nearest 10, five burnup values were chosen for the calculations:

1. 220 MWh/kgU; the highest median burnup of any decade.
2. 230 MWh/kgU; the 95th percentile burnup of the bundles discharged from Bruce B which is projected in Gobien and Ion (2019) to produce the most fuel waste of any Canadian reactor. It is also the 95th percentile burnup for the CANDU-6 reactors.
3. 250 MWh/kgU; the aggregate 95th percentile across all decades and reactors. This is also the aggregate 95th percentile burnup for the bundles discharged from Darlington, which is projected in Gobien and Ion (2019) to produce the second most fuel waste of any Canadian reactor.
4. 290 MWh/kgU; the highest 95th percentile of any decade.
5. 320 MWh/kgU; the highest 99th percentile of any decade.

Table 7: Maximum, Median, and Percentiles for Burnups and Power Ratings of Discharged Fuel from Canadian Power Reactors (Wilk 2013)

Reactor	Start of Decade	Burnup (MWh/kgU)					Bundle Power Rating (kW)				
		median	90 th	95 th	99 th	max	median	90 th	95 th	99 th	max
Bruce A	1970	130	230	250	280	360	570	740	770	810	880
	1980	200	260	270	300	710	700	840	860	900	1000
	1990	190	260	270	300	660	600	790	830	860	920
	2000	210	280	280	300	380	680	820	830	850	890
	2010	220	270	280	300	350	720	820	830	850	880
	all	200	260	280	300	710	660	820	840	880	1000
Bruce B	1980	180	220	230	270	490	670	730	750	770	810
	1990	190	220	220	250	410	630	710	730	750	810
	2000	190	220	230	240	440	630	680	690	710	770
	2010	190	220	230	250	450	650	700	700	720	770
	all	190	220	230	250	490	640	700	720	750	810
Pickering A	1980	200	230	250	290	520	500	590	610	650	740
	1990	200	270	290	320	520	560	650	660	680	760
	2000	200	270	280	290	430	550	640	650	670	700
	2010	210	280	290	300	350	560	640	650	670	690
	all	200	260	280	310	520	550	640	660	680	760
Pickering B	1980	190	220	230	250	480	550	620	640	670	740
	1990	190	230	240	260	600	550	620	640	660	730
	2000	190	230	240	250	550	550	600	620	630	680
	2010	200	230	240	250	470	550	610	620	640	680
	all	190	220	240	250	600	550	610	630	660	740
Darlington	1990	200	230	240	260	320	670	740	750	770	840
	2000	200	240	250	270	390	700	760	770	800	850
	2010	200	240	250	270	300	710	770	780	800	840
	all	200	240	250	270	390	690	760	770	790	850
Gentilly		170	210	230	240	350	650	800	830	860	920
Point Lepreau		170	210	230	250	320	650	780	810	840	1060
Aggregated		190	240	250	280	710	620	750	790	850	1060
MAX:		220	280	290	320	710	720	840	860	900	1060

5. SCREENING OF RADIONUCLIDES FOR SELECTION OF THE REFERENCE FUEL

In order to compare current models with prior ones, and to select a reference fuel bundle, a reduced set of key radionuclides was adopted. The basis for the reduced set is described here. (The full set of radionuclides was calculated for the reference fuel inventory.)

5.1 PROCESS

The radionuclides important to dose were identified by NWMO based on postclosure safety case studies for hypothetical sites in crystalline and sedimentary rock. Elements important to consider from potential chemical hazard perspective were similarly identified by NWMO.

The radionuclides important to gamma power, neutron intensity and thermal power were determined from an updated fuel analysis based on the reference fuel bundle and power selected in Tait et al. (2000) in order to facilitate comparison:

Bundle Type: 37-element Regular
 Burnup: 220 MWh/kgU
 Peak Power: 455 kW

For each decay period examined (discharge to 10^7 years), the radionuclides contributing to at least 0.1% of the total gamma power, neutron intensity, and thermal power were selected. The minimum 0.1% cut-off was used to reduce the list of radionuclides for cases where there were many radionuclides contributing only small amounts to the totals.

Only the fuel assessments were used in the screening study to determine the reference fuel bundle. However, for the comparison with prior Tait et al. (2000) results, the activation products in the Zircaloy assessments were selected using the same screening process¹.

5.2 SELECTED RADIONUCLIDES

All radionuclides identified as important from a dose, gamma power, neutron intensity or thermal power perspective are summarized in Appendix A, in the following tables:

- The radionuclides identified as significant for dose as indicated by NWMO are summarized in Table 8.
- The significant contributors to gamma radiation according to their total gamma power contribution are presented in Table 9, and Table 13.
- The significant contributors to neutron intensity according to the total neutron source intensity contribution are presented in Table 10.
- The significant contributors to decay heat radiation according to the total thermal power contribution are presented in Table 11, and Table 14.

A consolidated list of the significant nuclides for each decay period is provided in Table 12.

¹ Since only the light elements are assessed in the cladding, no neutron emissions are examined for Zircaloy.

The resulting set of key radionuclides is longer than, but substantively the same, as those selected in Tait et al. (2000), with differences primarily in radionuclides of lower overall importance. The main reasons for the different selection of radionuclides in this assessment versus those selected in Tait et al. (2000):

1. The current selection process uses the contribution to 99.9% gamma power, neutron intensity and thermal power as part of the total list of nuclides, rather than to 99% and a type-based contribution used in Tait et al. (2000).
2. Differences in the inputs, notably the Zr/U ratio and impurities.
3. Differences in the code versions and libraries used.

6. REGRESSION TESTING COMPARISONS WITH TAIT ET AL. (2000) INVENTORIES

The first step in the current analysis involved regression testing of the computer model against previous results (Tait et al. 2000). This was conducted using a burnup of 220 MWh/kgU. Testing involved comparisons with both the fuel and Zircaloy calculations.

The results using current input data, database libraries and computer models were compared with those used in the previous inventory analysis (Tait et al. 2000). Table 15 and Table 16 of Appendix B summarize the differences at an integrated level, in terms of total activity, thermal power, gamma flux and neutron intensity. For the Zircaloy results, the integrated totals represent only the radionuclides from the light element activation products since no fission products or actinides were tabulated in the Tait et al. (2000). The results are in close agreement for most of the fuel results, whereas large differences are observed in the Zircaloy results.

Specific differences larger than 5% were reviewed, and were explained by known changes in input, databases and analysis methods. The largest differences were generally at short times not relevant to waste management, or in small values likely of low actual consequence.

The differences in the results of the current calculations and those obtained by Tait et al. (2000) originate from a number of factors, notably:

1. Differences in the initial material compositions (i.e. impurity levels). The differences in initial Co, Ag and Pa impurities were particularly notable in the results, with the increased level of stable Pa impurity (1 wppm vs 0 in Tait et al. 2000) also leading to a significant increase in related nuclides including Pa-231(n, γ)Pa-232(β)U-232(α)Th-228(n, γ)Th-229(α)Ra-225(β)Ac-225(α)Fr-221.
2. Different nuclear data libraries. The general inclusion of more nuclides with very short half-lives (order of seconds to minutes) results in a significant increase in activity and photon emissions at discharge, decaying quickly after. Also, the data for specific radionuclides changed, such as the inclusion of gamma photons in SCALE 6.1.3 library for Nb-92, La-138 and Bi-208, relevant at long times.
3. Inclusion of delayed neutrons in SCALE 6.1.3, resulting in higher neutron intensities at the exact time of discharge, but decaying quickly after.
4. Increase in the (α ,n) intensity at discharge due to SCALE 6.1.3 calculation of activation of short-lived Bi-210, Po-210 and Po-211 from lighter elements.
5. Generation of burnup-dependent neutron cross-section libraries based on 238-group fine group data, rather than compilation from 27-group (ENDF/B-IV) and 89-group (WIMS-AECL format) allows finer representation of flux shape that affects fuel irradiation in SCALE 6.1.3.
6. Different cross-sections (ENDF/B-VII.0 vs JEFF-3.0/A) are selected in SCALE 6.1.3. In the current analysis, 388 nuclides were included at trace levels, resulting in updated cross-sections for a greater number of fission products and actinides.
7. Summed inventories from individual fuel element rings in current calculation would be more accurate than the bundle average weighting of fluxes in Tait et al. (2000).

8. Different pathways in the cross-section libraries. Notably, the SCALE 6.1.3 library includes Ni-59(n,p)Co-59, which could lead to increased Co-60 activity.
9. Different decay data. In particular, the half-life of Se-79 in SCALE 6.1.3 is much longer than in SCALE 4.2.
10. More accurate calculation method for the cladding radionuclides based on actual U/Zr ratio and on pro-rated inclusion of actinides and fission products.

7. REFERENCE FUEL BUNDLE SCREENING STUDY

Screening studies were performed to inform the selection of a reference fuel bundle. The reduced set of radionuclides of interest, as defined in Section 5, are examined in a comparison of the results for different fuel bundle characteristics.

Since the radiological attributes are proportional to the inventory of the selected radionuclides, the mass of the selected radionuclides will be compared in the screening studies. In addition, the total thermal power, gamma spectrum and neutron spectrum are compared where appropriate.

The following characteristics were examined:

1. Bundle Design: 28-element, 37R and 37M
2. Average bundle power: 200 kW, 455 kW, 720 kW, and 900 kW
3. Bundle Length: standard vs long bundles

It was concluded that a separate ORIGEN-S calculation for reference bundle for Point Lepreau and Gentilly-2 would not be needed, on the following basis:

- The CANDU 6 reactor core design is similar to the Pickering B reactor design.
- All CANDU reactors, including CANDU 6, have the same lattice pitch of 28.575 cm and use natural Uranium fuel.
- All CANDU reactors, including CANDU 6, use similar materials for the core components (pressure tubes/calandria tubes/calandria shell/guide tubes/etc).
- There are differences in CANDU designs related to the primary heat transport conditions with some reactors (Darlington, CANDU 6) having quality in the channel outlet, but these differences are not expected to have significant impact on the core fluxes.
- A comparison performed in Wilk (2013) shows that the median bundle powers for all CANDU/CANDU 6 stations are similar ~650 kW (except Pickering A/B with ~550 kW). The median burnups for CANDU 6 are ~170 MWh/kgU compared to the CANDU reactors ~190 MWh/kgU and this depends on the operational history of each station.

Therefore, in the context of the current project, from reactor physics perspective, there are no significant differences between the Ontario CANDU and CANDU 6 reactors. In addition, the only significant differences in CANDU 6 fuel bundle design is the positioning of the bearing pad and the design of the end plate.

A burnup of 230 MWh/kgU was assessed for all screening studies. Generally, the 37R bundle at 200 kW was used as a reference point in the screening studies.

7.1 BUNDLE DESIGN

7.1.1 28-Element Bundle vs Regular 37-Element Bundle

The results of the bundle design screening studies are presented in Appendix C.

ORIGEN calculations for a 28-element fuel were carried out using a TRITON based library constructed with fuel parameters specific to 28-element bundles. The comparison between the inventories of significant radionuclides in a 28-element fuel bundle relative to 37R per kg initial Uranium (kgU) (at 200 kW peak power, 230 MWh/kgU burnup) are shown in Table 17.

At discharge there are differences up to 9% (Np-240 and Np-240m). The largest percent differences at 10 years are in Po-210 and Pb-210, which both have small quantities.

The percent difference in the inventory of the significant radionuclides generally decreases with decay time, such that by 10 years after discharge, all but Pb-210 and Po-210 have lower than 5% difference, and at 100 years after discharge, the only radionuclides with a greater than 3% difference between the bundles are Cs-135 and Pu-238 for which the percent difference at discharge remains constant throughout the decay.

The comparison between the inventory of significant elements in a 28-element bundle and a 37R bundle (200 kW, 230 MWh/kgU) is shown in Table 18. Most significant elements show a very small increase in the 28-element bundle relative to the 37R bundle, though the difference is less than 2% in all significant elements except for Po (5%) up to 70 years, and Tc (4%) at 10⁷ years.

If the total bundle inventory is considered, because the 28-element bundle contains a larger mass of fuel, the total bundle inventories of the significant radionuclides are generally 4-10% higher in the 28-element bundle. The exception is only at discharge where Np-240, Np-240m, Pm-148, and Th-234 are all slightly higher in the 37R bundle. The inventories of all significant elements are similarly higher by ~4-10% in the 28-element fuel on a bundle basis.

Consistent with the differences in the significant radionuclide inventories, there is slightly more thermal power per kg U in the 28-element bundle, as shown in Table 19. The highest difference in total thermal power aside from at discharge, is 0.9% at 10⁵ years decay. There are negligible differences in the total gamma power per kg U, as shown in Table 20. As for total neutron intensity, there is a slight increase in the neutron power in the first 100 years, and a slight decrease in all subsequent decay periods as shown in Table 21.

7.1.2 Modified 37-Element Bundle vs Regular 37-Element Bundle

The differences in all significant radionuclides, elements and integrated quantities between the 37M and the 37R bundles are all very small per kg U (<1%), as shown in Table 19 to Table 23. On a bundle basis, there are fewer nuclides and elements since the 37M bundle contains less Uranium than the 37R bundle. Per Table 22 the only difference in radionuclide inventory greater than 1%, aside from at discharge, occurs in Cm-246, of which there is 1.3% less in the 37M bundle relative to the 37R bundle, however, the quantity of this nuclide is low. Even at discharge there are no noticeable differences in the significant nuclide inventories.

7.1.3 Bundle Length (Standard vs Long)

Long bundles are used in the reactor in conjunction with standard length bundles, so the burnup per kg U and the power per bundle unit length (linear bundle power) should be similar for the two bundle types. The ratio of fuel to cladding is about 1% higher in long bundles.

The screening studies in Tait et al. (2000) evaluated the difference in the standard vs long bundle on the basis of thermal and gamma power per kg U, since these integrated properties are directly proportional to radionuclide activity (Bq/kgU), and would show any significant overall changes in inventory. The results indicated that the differences between the two cases are less than 0.02% at 10 years out-of-reactor. It was thus concluded in Tait et al. (2000) that there is no need to specifically account for the behaviour of long bundles in calculating radionuclide inventories on a per kg basis.

These conclusions are considered still applicable.

7.2 POWER DEPENDENCE

Every bundle in the reactor core will have occupied perhaps 2, 3, or 4 different positions in the fuel channel prior to its discharge from the reactor and will therefore have experienced a number of different power levels during its irradiation. The nuclide inventory analysis presented in this report is based on constant power irradiation. One of the objectives is to demonstrate that time-varying power levels do not significantly affect the inventory of most radionuclides at relevant cooling times by considering constant power levels at the likely extremes of the time-varying power history.

7.2.1 Fuel Inventory

The significant nuclides and significant element inventories are somewhat dependent on the bundle power. The differences increase with the bundle power, with the differences between the 900 kW and the 200 kW bundles being the greatest. However, the direction of the change (increase or decrease) in inventory is dependent of the nuclide and timeframe. About half the nuclides selected for importance are higher at 200 kW, and the other half are higher at 900 kW. Significant differences are seen in the first 200 years of decay. After this point, large differences (>10%) remain in only a few nuclides and elements. The largest differences are seen in Cs-135 and Pu-238, consistent with the findings in Tait et al. (2000). At 900 kW, these nuclides decrease to about 30% (Cs-135) and 65% (Pu-238) of their 200 kW inventory.

As described in Tait et al. (2000), the reason for the inverse relationship between Cs-135 concentration and bundle power is because it is produced by both direct fission of U-235 and by decay of three other fission products, Te-135, I-135 and Xe-135, which have very short half-lives (Te-135 → I-135 → Xe-135 → Cs-135). Since Xe-135 has a very large neutron capture cross-section, it is burned out at high powers, which means that the contribution of Xe-135 decay to the concentration of Cs-135 will be decreased.

The specific reason for the inverse dependence in the concentration of Pu-238 with power is not clear. It also is produced through multiple neutron absorption and decay stages, so presumably one of these stages also has a high cross-section for a different pathway.

7.2.2 Thermal Power

The thermal power immediately at discharge at 900 kW is about 4.5x that at 200 kW; it is essentially proportional to bundle power over this range. However, this quickly declines. By 5 years, the 900 kW bundle has 19% more thermal power, while by 10 years and after it is less than 3% higher than a 200 kW bundle.

7.2.3 Gamma Power

The same general proportional differences are seen as with thermal power. The gamma power is proportional to bundle power at discharge, decreasing to 12% difference by 5 years, and 3.2% or less by 10 years and later.

7.2.4 Neutron Power

As above, the neutron power at discharge is directly proportional to the increase in power (~0.5% increase per kW increase). At 5 years and later, the difference in neutron power for different bundle powers is less than 1.5% total.

7.3 SELECTION OF A REFERENCE FUEL

The screening results have shown some small differences with respect to the bundle type and bundle power. The differences are along the same trends as demonstrated in similar screening studies report in Tait et al. (2000), but with higher magnitude.

There are generally negligible differences in all inventory and radioactivity characteristics between the 37R and the 37M bundles. Where small differences are seen, the 37R quantities are slightly higher. Therefore, between the two bundle types, the 37R bundle is preferred as a reference fuel for conservatism.

The differences between the 37R and the 28-element bundle show slightly higher values for the 28-element bundle in the significant nuclides and elements. However, the differences of most significant nuclides are less than ~5% on a per kg basis. The integrated thermal power is also slightly higher in the 28-element bundle, but by less than 1% at all decay times. The integrated gamma power shows negligible differences between the two bundles, and the neutron power is only slightly (~1%) higher in the 28-element bundle at shorter decay times, and ~1% lower at the longer decay times.

It is therefore confirmed that the bundle type does not significantly impact the inventory amounts or characterization and the selection could instead be based on forecasted abundance. Based on current forecasts for the bundle inventories, it is estimated that about 83% of the total bundle inventory that will be placed in the deep geological repository will be the 37-element design (Gobien and Ion 2019). The reference bundle selected for calculation of radionuclide inventories in this report is therefore the 37R bundle. (Calculated on a per kg basis; actual bundle inventories should consider the specific fuel bundle mass.)

Significant differences are seen in several significant radionuclides irradiated at different power levels. The resulting impact on the integrated neutron power, gamma power and thermal power may be considered negligible (less than 3%). While no clear trend was observed with respect to the relation of bundle power to radionuclide inventory for the significant nuclides and elements at a given burnup, when the results for a given decay time are examined, the power level for which the maximum total inventories are observed are consistent with the Tait et al. (2000) results.

The bundle power rating level selected as reference value for calculation of radionuclide inventories is 720 kW, which represents the highest median observed in any decade (Table 7).

The highest median burnup observed in any decade, 220 MWh/kgU was selected for calculation of the reference inventory in this report. Additional calculations were performed for 290 MW/kgU, which represents the highest 95th percentile burnup observed in any decade.

8. CALCULATIONS OF RADIONUCLIDE INVENTORY FOR USED NUCLEAR FUEL USING THE ORIGEN-S CODE

The reference libraries and methodology for the calculations of the radionuclide inventories are provided in Section 2.

In addition to the ORIGEN-S results, the reference half-lives for radionuclides used in estimation of inventories are included in this report. While there are various sources that could be used for the half-lives, and they are relatively consistent for the majority of radionuclides, in some cases there may be small differences between the reported half-lives. The half-life data included in the libraries used with the current version of the ORIGEN-S code are provided in Table 24, Table 25, and Table 26 of Appendix D, for the actinides, fission products and light elements (impurity activation products) respectively.

The results are presented in Appendix E for each burnup (220 MWh/kgU and 290 MWh/kgU) and for the power of 720 kW/bundle. For each burnup and power, the total radionuclide activity (Bq/kgU) and total thermal power (W/kgU), are presented for UO₂ fuel and separately for the Zircaloy cladding.

- 220 MWh/kgU, 720 kW/bundle:
 - The total radionuclide activity for UO₂ fuel and for Zircaloy cladding are presented in Table 27 and Table 28 respectively.
 - The total thermal power for UO₂ fuel and for cladding are presented in Table 29.
- 290 MWh/kgU, 720 kW/bundle:
 - The total radionuclide activity for UO₂ fuel and for Zircaloy cladding are presented in Table 30 and Table 31 respectively.
 - The total thermal power for UO₂ fuel and for cladding are presented in Table 32.

9. SUMMARY

The inventories of nuclides in CANDU used fuel are important parameters in safety assessments carried out by NWMO. The radionuclide inventories include actinides and fission products in the UO₂ fuel, neutron activated impurities in the UO₂ and Zircaloy cladding, and trace actinides and fission products in the Zircaloy cladding.

The dimensional properties and composition of CANDU fuel bundles were reviewed and representative data were provided. This data was necessary for calculating the radionuclide inventories in the fuel and cladding.

The inventory compilation produced in Tait et al. (2000) were examined in comparison to updated results using ORIGEN-S 6.1.3, updated nuclear data libraries, updated fuel and cladding composition data, and also based on more accurate element ring analyses rather than bundle average. Significant differences were found, primarily due to the nuclear data libraries and fuel impurities. The largest differences were noted at early decay times or in low values, as the updated libraries include more radionuclides (e.g. they include the very short half-life nuclides as well), and there are finer representations of the cross-section libraries. In addition, different initial material compositions (i.e. impurity levels) were used based on more recent available data, and a more accurate calculation method was used for the cladding radionuclides, which was based on actual U/Zr ratio and on pro-rated inclusion of actinides and fission products. The new results with ORIGEN-S 6.1.3 are expected to be more accurate.

The screening studies examining the bundle design (i.e. 28-element and modified 37-element vs regular 37-element) showed only small (~5%) differences. A selection of a reference bundle type can be made based on the expected abundance of bundle types. Current forecast bundle inventories of used 28-element and used 37-element bundle indicate that about 83% of the total bundle inventory will be the 37-element design (Gobien and Ion 2019). The reference bundle selected for calculation of radionuclide inventories was therefore the 37R element. (Calculated on a per kg basis; actual inventories should be based on the specific fuel bundle mass.)

The screening studies examining the bundle power demonstrated significant differences in the inventories of many of the selected radionuclides, though mostly at < 200 years, and also only small (<3%) differences in the total integrated quantities. For this report, a power of 720 kW, which represents the highest median bundle power rating of any decade, was selected. Depending on the application and specific nuclides or elements of interest, the radionuclide inventories and characteristics associated with different power levels may be required as no universally bounding bundle power can be identified.

The total radionuclide inventory and thermal power are presented as a function of decay time for a reference 37R bundle of 220 MWh/kgU, which represents the highest median burnup of any decade, and power of 720 kW/bundle. In addition, the data are presented for a burnup 290 MWh/kgU, which represents the highest 95th percentile burnup of any decade.

REFERENCES

- ATI. 2017. Zirconium alloys technical data sheet. Downloaded 14 December 2017.
- Chadwick, M.B., P. Oblozinsky, M. Herman, N.M. Greene, R. McKnight, D.L. Smith, P. Young, R.E. MacFarlane, G.M. Hale, S.C. Frankle, A.C. Kahler, T. Kawano, R.C. Little, D.G. Madland, P. Moller, R.D. Mosteller, P.R. Page, P. Talou, H. Trellue, M.C. White, W.B. Wilson, R. Arcilla, C.L. Dunford, S.F. Mughabghab, B. Pritychenko, D. Rochman, A. Sonzogni, C.R. Lubitz, T.H. Trumbull, J.P. Weinman, D.A. Brown, D.E. Cullen, D.P. Heinrichs, D.P. McNabb, H. Derrien, M.E. Dunn, N.M. Larson, L.C. Leal, A.D. Carlson, R.C. Block, J.B. Briggs, E.T. Cheng, H.C. Huria, M.L. Zerkle, K.S. Kozier, A. Courcelle, V. Pronyaev and S.C. van der Marck. 2006. ENDF/B-VII.0: Next generation evaluated nuclear data library for nuclear science and technology. Nucl. Data Sheets 107(12), 2931-3060.
- Chadwick, M.B., M. Herman, P. Oblozinsky, M.E. Dunn, Y. Danon, A.C. Kahler, D.L. Smith, B. Pritychenko, G. Arbanas, R. Arcilla, R. Brewer, D.A. Brown, R. Capote, A.D. Carlson, Y.S. Cho, H. Derrien, K. Guber, G.M. Hale, S. Hoblit, S. Holloway, T.D. Johnson, T. Kawano, B.C. Kiedrowski, H. Kim, S. Kunieda, N.M. Larson, L. Leal, J.P. Lestone, R.C. Little, E.A. McCutchan, R.E. MacFarlane, M. MacInnes, C.M. Mattoon, R.D. McKnight, S.F. Mughabghab, G.P.A. Nobre, G. Palmiotti, A. Palumbo, M.T. Pigni, V.G. Pronyaev, R.O. Sayer, A.A. Sonzogni, N.C. Summer, P. Talou, I.J. Thompson, A. Trkov, R.L. Vogt, S.C. van der Marck, A. Wallner, M.C. White, D. Wiarda and P.G. Young. 2011. ENDF/B-VII.1 Nuclear data for science and technology: cross Sections, covariances, fission product yields and decay data. Nucl. Data Sheets 112(12), 2887-2996.
- Gauld, I.C., P.A. Carlson and K.A. Litwin. 1995a. Production and validation of ORIGEN-S cross-section libraries for CANDU reactor fuel studies. Atomic Energy of Canada Limited Report RC-1442, COG-I-95-200. Pinawa, Canada.
- Gauld, I.C. and K.A. Litwin. 1995b. Verification and validation of the ORIGEN-S code and nuclear data libraries. Atomic Energy of Canada Limited Report RC-1429, COG-I-95-150. Pinawa, Canada.
- Gauld, I.C., E.F. Shores and R.T. Perry. 2002. New neutron source algorithms in the ORIGEN-S code. Proc. of American Nuclear Society 2002 Winter Meeting, April 14-18, 2002. Santa Fe, New Mexico, USA.
- Gobien, M. and M. Ion. 2019. Nuclear fuel waste projections in Canada - 2019 update. Nuclear Waste Management Organization Report NWMO-TR-2019-14. Toronto, Canada.
- Jesse, M.A. and M.D. DeHart. 2011. TRITON: A two-dimensional transport and depletion module for characterization of spent nuclear fuel. Oak Ridge, USA.
- Liberda, K., H. Leung, P. Gierszewski and L. Orlovskaya. 2019. Elemental composition of unirradiated CANDU fuel. Presented at 14th International Conference on CANDU Fuel, July 21-24, 2019. Mississauga, Canada.

- Meija, J., T.B. Coplen, M. Berglund, W.A. Brand, P. De Bièvre, M. Groning, N.E. Holden, J. Irrgeher, R.D. Loss, T. Walczyk and T. Prohaska. 2016a. Atomic weights of the elements 2013 (IUPAC Technical Report). *J. Pure Appl. Chem.* **88(3)**, 265-291.
- Meija, J., T.B. Coplen, M. Berglund, W.A. Brand, P. De Bièvre, M. Groning, N.E. Holden, J. Irrgeher, R.D. Loss, T. Walczyk and T. Prohaska. 2016b. Isotopic compositions of the elements. *J. Pure Appl. Chem.* **88(3)**, 293-306.
- ORNL. 2011. SCALE: A comprehensive modeling and simulation suite for nuclear safety analysis and design. Available from Radiation Safety Information Computation Center at Oak Ridge National Laboratory as CCC-785. Oak Ridge, USA.
- ORNL. 2013. SCALE Newsletter, Reactor and Nuclear Systems Division of the Oak Ridge National Laboratory. Oak Ridge, USA.
- Petrie L.M. and B.T. Rearden. 2011. MCDANCOFF data guide. Oak Ridge, USA.
- Sublet, J.-C., A.J. Koning, R.A. Forrest and J. Kopecky. 2003. The JEFF-3.0/A neutron activation file - EAF-2003 into ENDF-6 format. Commissariat à l'Énergie Atomique JEFDOC-982, France.
- Tait, J.C. and L. Johnson. 1997. Waste management issues and their potential input on technical specifications of CANDU fuel materials. Proc. 5th International Conference on CANDU Fuel, September 21-25, 1997. Toronto, Canada.
- Tait, J.C., H. Roman and C.A. Morrison. 2000. Characteristics and radionuclide inventories of used fuel from OPG nuclear generating stations - Volume 1 - Main Report. Ontario Power Generation Report 06819-REP-01200-10029-R00. Toronto, Canada.
- Tait, J.C. and S. Hanna. 2001. Characteristics and radionuclide inventories of used fuel from OPG nuclear generating stations - Volume 3 - Radionuclide inventory data decay times 10 to 300 years. Ontario Power Generation Report 06819-REP-01200-10029-R00. Toronto, Canada.
- Wasywich, K.M. 1993. Characteristics of used CANDU fuel relevant to the Canadian nuclear fuel waste management program. Atomic Energy of Canada Limited Report, AECL-10463, COG-91-340. Pinawa, Canada.
- Wilk, L. 2013. CANDU fuel burnup and power rating 2012 update. Nuclear Waste Management Organization Report NWMO TR-2013-02. Toronto, Canada.
- Williams, M.L. and D.F. Hollenbach. 2011. CENTRM: A one-dimensional neutron transport code for computing pointwise energy spectra. Oak Ridge, USA.

APPENDIX A: RESULTS OF THE ORIGEN-S RADIONUCLIDE SCREENING STUDIES**CONTENTS**

		Page
A.1	SELECTION OF IMPORTANT RADIONUCLIDES AND ELEMENTS IN THE FUEL	35
A.2	SELECTION OF IMPORTANT RADIONUCLIDES AND ELEMENTS IN THE CLADDING	42

A.1 Selection of Important Radionuclides and Elements in the Fuel

Table 8: Nuclides and Elements Important to Dose as Indicated by NWMO

Fuel			Zircaloy	
Radionuclides		Elements	Radionuclides	Elements
Ac 225	Rn 222	Ag	C 14	Te
Ac 227	Sb 126	Br	Cl 36	
Bi 210	Se 79	Bi		
C 14	Sn 126	Cd		
Ca 41	Sm 147	Hg		
Cl 36	Sr 90	I		
Cs 135	Tc 99	Mo		
I 129	Th 227	Nd		
Np 237	Th 228	Pd		
Pa 231	Th 229	Rh		
Pa 233	Th 230	Ru		
Pb 210	Th 232	Sb		
Pd 107	Th 234	Se		
Po 210	U 233	Tc		
Ra 223	U 234	Te		
Ra 224	U 235	W		
Ra 225	U 236			
Ra 226	U 238			
Ra 228				

Table 9: Radionuclides Contributing at least 0.1% of Gamma Power in Fuel at Each Decay Period²

	Decay Time [years]																	
	0	5	10	15	20	30	40	50	70	100	200	300	500	1000	1.0E+04	1.0E+05	1.0E+06	1.0E+07
1	Np 239	Ba 137m	Ba 137m	Ba 137m	Ba 137m	Ba 137m	Ba 137m	Ba 137m	Ba 137m	Ba 137m	Ba 137m	Ba 137m	Am 241	Am 241	Pu 240	Bi 214	Bi 214	Bi 214
2	Nb 95	Cs 134	Cs 134	Eu 154	Eu 154	Eu 154	Eu 154	Am 241	Am 241	Am 241	Am 241	Am 241	Pu 240	Pu 240	Sb 126m	Sb 126m	Pb 214	Pb 214
3	Zr 95	Rh 106	Eu 154	Cs 134	Cs 134	Am 241	Am 241	Eu 154	Tl 208	Tl 208	Tl 208	Tl 208	Np 239	Np 239	Np 239	Pa 233	Pa 233	Pa 234m
4	Ru 103	Eu 154	Sb 125	Sb 125	Am 241	Tl 208	Tl 208	Tl 208	Eu 154	-	Pu 240	Pu 240	Ba 137m	Sb 126m	Pa 233	Pb 214	Bi 213	Th 234
5	Rh 106	Sb 125	Rh 106	Am 241	-	-	-	-	-	-	Np 239	Np 239	Sb 126m	Am 243	Pu 239	Sb 126	Th 229	Ra 226
6	Ce 141	Pr 144	Co 60	-	-	-	-	-	-	-	Pb 212	Sb 126m	Tl 208	Pu 239	Bi 214	Bi 213	Tl 209	Pa 233
7	Pm 148	Ce 144	-	-	-	-	-	-	-	-	-	Pb 212	Am 243	Pa 233	Sb 126	Th 229	Sb 126m	Pb 210
8	Cs 134	Co 60	-	-	-	-	-	-	-	-	-	Am 243	Pu 239	Sb 126	Am 243	Np 237	Pa 234m	U 235
9	Np 238	Eu 155	-	-	-	-	-	-	-	-	-	Pu 239	Sb 126	-	Np 237	Tl 209	Np 237	Th 227
10	Ba 137m	-	-	-	-	-	-	-	-	-	-	Bi 212	Pa 233	-	Bi 213	Pa 234m	Fr 221	Ra 223
11	U 237	-	-	-	-	-	-	-	-	-	-	-	-	-	Pa 234m	Fr 221	Ac 225	Bi 213
12	Np 240	-	-	-	-	-	-	-	-	-	-	-	-	-	Th 229	Pu 239	Th 234	Th 229
13	Pr 144	-	-	-	-	-	-	-	-	-	-	-	-	-	Pb 214	Sn 126	Ra 226	Pa 234
14	Pm 148m	-	-	-	-	-	-	-	-	-	-	-	-	-	Sn 126	Th 234	Ra 225	U 234
15	Te 129	-	-	-	-	-	-	-	-	-	-	-	-	-	Th 227	Ac 225	Pb 210	-
16	Ce 144	-	-	-	-	-	-	-	-	-	-	-	-	-	Ra 223	Ra 225	U 235	-
17	Np 240m	-	-	-	-	-	-	-	-	-	-	-	-	-	Th 234	Th 227	Th 227	-
18	Pa 233	-	-	-	-	-	-	-	-	-	-	-	-	-	Tl 209	U 235	Sb 126	-
19	-	-	-	-	-	-	-	-	-	-	-	-	-	-	Pb 211	Ra 223	Ra 223	-
20	-	-	-	-	-	-	-	-	-	-	-	-	-	-	Fr 221	Ra 226	Pa 234	-
21	-	-	-	-	-	-	-	-	-	-	-	-	-	-	Rn 219	Pb 210	-	-
22	-	-	-	-	-	-	-	-	-	-	-	-	-	-	Bi 211	Nb 93m	-	-
23	-	-	-	-	-	-	-	-	-	-	-	-	-	-	Nb 94	Pa 234	-	-
24	-	-	-	-	-	-	-	-	-	-	-	-	-	-	Pa 231	Pb 211	-	-
25	-	-	-	-	-	-	-	-	-	-	-	-	-	-	Nb 93m	Rn 219	-	-
26	-	-	-	-	-	-	-	-	-	-	-	-	-	-	U 235	U 234	-	-
27	-	-	-	-	-	-	-	-	-	-	-	-	-	-	Pa 234	-	-	-
28	-	-	-	-	-	-	-	-	-	-	-	-	-	-	Ac 225	-	-	-
29	-	-	-	-	-	-	-	-	-	-	-	-	-	-	Ra 225	-	-	-

² Note: At discharge (0.0 years decay), nuclides that are short lived (such that they have zero inventory at 5 years decay) are not included in this list, many of which would contribute to 99.9% of the total gamma power.

Table 10: Radionuclides Contributing at least 0.1% of Neutron Intensity in Fuel at Each Decay Period³

	Decay Time [years]																	
	0.0	5.0	10.0	15.0	20.0	30.0	40.0	50.0	70.0	100.0	200.0	300.0	500.0	1.0E+03	1.0E+04	1.0E+05	1.0E+06	1.0E+07
1	Cm 242	Cm 244	Cm 244	Cm 244	Cm 244	Cm 244	Pu 240	Pu 240	Pu 240	Pu 240	Pu 240	Pu 240	Pu 240	Pu 240	Pu 240	Pu 242	Pu 242	U 238
2	Cm 244	Pu 240	Pu 240	Pu 240	Pu 240	Pu 240	Cm 244	Cm 244	Am 241	Am 241	Am 241	Am 241	Am 241	Pu 242	Pu 242	U 238	U 238	Po 214
3	Pu 240	Pu 242	Am 241	Am 241	Am 241	Am 241	Am 241	Am 241	Cm 244	Pu 242	Pu 242	Pu 242	Pu 242	Am 241	Pu 239	Pu 239	Po 214	Po 218
4	Pu 242	Am 241	Pu 242	Pu 242	Pu 242	Pu 242	Pu 242	Pu 242	Pu 242	Cm 244	Pu 239	Pu 239	Pu 239	Pu 239	U 238	Po 214	Po 218	Rn 222
5	Pu 239	Pu 238	Pu 239	Pu 239	Pu 239	Pu 239	Pu 239	Pu 239	Pu 239	Pu 239	Pu 238	U 238	U 238	U 238	Cm 246	Po 218	Rn 222	Po 210
6	Pu 238	Pu 239	Pu 238	Pu 238	Pu 238	Pu 238	Pu 238	Pu 238	Pu 238	Pu 238	U 238	Pu 238	Cm 246	Cm 246	-	At 217	At 217	Ra 226
7	-	U 238	U 238	U 238	U 238	U 238	U 238	U 238	U 238	U 238	Cm 246	Cm 246	Pu 238	-	-	Po 213	Po 210	U 234
8	-	Cm 242	Po 216	Po 216	Po 216	Po 216	Po 216	Po 216	Po 216	Cm 246	Cm 244	-	-	-	-	-	Po 213	Th 230
9	-	Po 216	Rn 220	Rn 220	Rn 220	Rn 220	Rn 220	Rn 220	Rn 220	Po 216	-	-	-	-	-	-	Fr 221	U 236
10	-	Rn 220	Po 212	Po 212	Po 212	Po 212	Cm 246	Cm 246	Cm 246	Rn 220	-	-	-	-	-	-	Ra 226	-
11	-	Po 212	Ra 224	Ra 224	Ra 224	Ra 224	Po 212	Po 212	Po 212	Po 212	-	-	-	-	-	-	Ac 225	-
12	-	Ra 224	Th 228	Th 228	Cm 246	Cm 246	Ra 224	Ra 224	Ra 224	Ra 224	-	-	-	-	-	-	U 234	-
13	-	-	Cm 246	Cm 246	Th 228	Th 228	Th 228	Th 228	Th 228	Th 228	-	-	-	-	-	-	Th 230	-
14	-	-	U 232	U 232	U 232	U 232	U 232	U 232	U 232	-	-	-	-	-	-	-	Th 229	-
15	-	-	-	-	-	-	-	-	-	-	-	-	-	-	-	-	U 233	-
16	-	-	-	-	-	-	-	-	-	-	-	-	-	-	-	-	Np 237	-
17	-	-	-	-	-	-	-	-	-	-	-	-	-	-	-	-	U 236	-

³ Note: At discharge (0.0 years decay), nuclides that are short lived (such that they have zero inventory at 5 years decay) are not included in this list, many of which would contribute to 99.9% of the total neutron intensity.

Table 11: Radionuclides Contributing at least 0.1% of Thermal Power in Fuel at Each Decay Period⁴

	Decay Time [years]																	
	0.0	5.0	10.0	15.0	20.0	30.0	40.0	50.0	70.0	100.0	200.0	300.0	500.0	1.0E+03	1.0E+04	1.0E+05	1.0E+06	1.0E+07
1	Np 239	Ba 137m	Ba 137m	Ba 137m	Ba 137m	Ba 137m	Ba 137m	Ba 137m	Am 241	Am 241	Am 241	Am 241	Am 241	Pu 240	Pu 239	Pu 239	Po 214	Po 214
2	Zr 95	Y 90	Y 90	Y 90	Y 90	Y 90	Y 90	Y 90	Ba 137m	Ba 137m	Pu 240	Pu 240	Pu 240	Am 241	Pu 240	Pu 242	Po 218	Po 218
3	Nb 95	Rh 106	Cs 137	Cs 137	Cs 137	Am 241	Am 241	Am 241	Y 90	Y 90	Pu 239	Pu 239	Pu 239	Pu 239	Am 243	U 234	Rn 222	Rn 222
4	Pr 144	Pr 144	Sr 90	Am 241	Am 241	Cs 137	Cs 137	Cs 137	Pu 240	Pu 240	Ba 137m	Pu 238	Pu 238	Am 243	Pu 242	Po 214	Po 210	Po 210
5	Ru 103	Cs 134	Am 241	Sr 90	Sr 90	Sr 90	Pu 240	Pu 240	Cs 137	Pu 239	Y 90	Ba 137m	Am 243	-	U 234	U 238	Ra 226	Ra 226
6	Rh 106	Cs 137	Pu 240	Pu 240	Pu 240	Pu 240	Sr 90	Sr 90	Pu 239	Cs 137	Pu 238	Y 90	-	-	U 238	Po 218	Th 230	U 234
7	Y 91	Sr 90	Cs 134	Pu 239	Pu 239	Pu 239	Pu 239	Pu 239	Sr 90	Sr 90	Cs 137	Am 243	-	-	-	Po 213	U 234	Th 230
8	Sr 89	Pu 240	Pu 239	Pu 238	Pu 238	Pu 238	Pu 238	Pu 238	Pu 238	Pu 238	Sr 90	-	-	-	-	Np 237	Po 213	U 238
9	Ce 141	Pm 147	Eu 154	Eu 154	Eu 154	Eu 154	Cm 244	Po 216	Po 216	Po 216	Po 216	-	-	-	-	Rn 222	U 238	Bi 214
10	Te 129	Am 241	Pu 238	Kr 85	Kr 85	Kr 85	Eu 154	Rn 220	Rn 220	Rn 220	Rn 220	-	-	-	-	Po 210	At 217	U 236
11	Pm 148	Eu 154	Rh 106	Cs 134	Cm 244	Cm 244	Kr 85	Cm 244	Ra 224	Ra 224	Ra 224	-	-	-	-	At 217	Fr 221	Pa 234m
12	Ce 144	Pu 239	Kr 85	Cm 244	Pu 241	Po 216	Po 216	Ra 224	Po 212	Po 212	Po 212	-	-	-	-	Ra 226	Ac 225	Pb 214
13	Ag 110	Ce 144	Pm 147	Pm 147	Po 216	Rn 220	Rn 220	Po 212	Th 228	Th 228	Th 228	-	-	-	-	Th 230	Th 229	Bi 210
14	Rh 103m	Pu 238	Cm 244	Pu 241	Rn 220	Ra 224	Ra 224	Th 228	U 232	U 232	U 232	-	-	-	-	Fr 221	U 233	Po 213
15	U 237	Sb 125	Sb 125	Po 216	Ra 224	Po 212	Po 212	U 232	Cm 244	-	-	-	-	-	-	Ac 225	Np 237	Po 215
16	Cs 134	Kr 85	Pu 241	Rn 220	Po 212	Th 228	Th 228	Kr 85	-	-	-	-	-	-	-	Th 229	Bi 214	Rn 219
17	Np 238	Cm 244	Pr 144	Ra 224	Th 228	U 232	U 232	Eu 154	-	-	-	-	-	-	-	U 233	U 236	At 217
18	Np 240m	Pu 241	Po 216	Po 212	U 232	Pu 241	-	-	-	-	-	-	-	-	-	U 236	Pu 242	Bi 211
19	Np 240	Ru 106	Rn 220	Th 228	Cs 134	-	-	-	-	-	-	-	-	-	-	Bi 214	Pa 234m	Th 227
20	Cm 242	-	Ra 224	U 232	-	-	-	-	-	-	-	-	-	-	-	Pa 234m	Pb 214	Fr 221
21	Ag 109m	-	Po 212	Sb 125	-	-	-	-	-	-	-	-	-	-	-	Tc 99	Bi 210	Ra 223
22	Y 90	-	Th 228	-	-	-	-	-	-	-	-	-	-	-	-	Sb 126m	Bi 213	Ac 225
23	Ba 137m	-	U 232	-	-	-	-	-	-	-	-	-	-	-	-	Pb 214	Po 215	Pa 231
24	Te 127	-	-	-	-	-	-	-	-	-	-	-	-	-	-	Bi 213	Pa 233	Th 229
25	Pm 148m	-	-	-	-	-	-	-	-	-	-	-	-	-	-	Pa 233	Rn 219	Np 237
26	-	-	-	-	-	-	-	-	-	-	-	-	-	-	-	Po 215	Bi 211	U 235
27	-	-	-	-	-	-	-	-	-	-	-	-	-	-	-	Rn 219	Th 227	U 233
28	-	-	-	-	-	-	-	-	-	-	-	-	-	-	-	Bi 210	Ra 223	Th 234
29	-	-	-	-	-	-	-	-	-	-	-	-	-	-	-	Bi 211	Pa 231	-
30	-	-	-	-	-	-	-	-	-	-	-	-	-	-	-	-	U 235	-
31	-	-	-	-	-	-	-	-	-	-	-	-	-	-	-	-	Pb 209	-

⁴ Note: At discharge (0.0 years decay), nuclides that are short lived (such that they have zero inventory at 5 years decay) are not included in this list, many of which would contribute to 99.9% of the total decay heat.

A.2 Selection of Important Radionuclides and Elements in the Cladding

Table 13: Light Element Radionuclides Contributing at least 0.1% of Gamma Power in Zircaloy at Each Decay Period⁵

	Decay Time [years]																	
	0.0	5.0	10.0	15.0	20.0	30.0	40.0	50.0	70.0	100.0	200.0	300.0	500.0	1.0E+03	1.0E+04	1.0E+05	1.0E+06	1.0E+07
1	Nb 95	Co 60	Co 60	Co 60	Co 60	Co 60	Co 60	Co 60	Co 60	Nb 94	Nb 94	Nb 94	Nb 94	Nb 94	Nb 94	Nb 94	Nb 93m	Nb 93m
2	Zr 95	Sb 125	Sb 125	Sb 125	Sb 125	Sb 125	Nb 94	Nb 94	Nb 94	Ag 108m	Ag 108m	Ag 108m	Ag 108m	Ag 108m	Nb 93m	Nb 93m	Ta 182	Ta 182
3	Sc 46	Cs 134	-	-	-	Nb 94	Sb 125	Ag 108m	Ag 108m	Co 60	Nb 93m	Nb 93m	Nb 93m	Nb 93m	Ni 59	Ni 59	Hf 182	Hf 182
4	Co 60	Te 125m	-	-	-	-	-	Eu 154	Sn 121m	Sn 121m	Ni 59	Ni 59	Ni 59	Ni 59	-	Ta 182	Cl 36	K 40
5	Ta 182	-	-	-	-	-	-	-	Eu 154	Nb 93m	Sn 121m	Ho 166m	Ho 166m	Ho 166m	-	Cl 36	Co 60	Nb 92
6	Hf 181	-	-	-	-	-	-	-	Nb 93m	Ni 59	Ho 166m	-	-	-	-	-	-	-
7	In 113m	-	-	-	-	-	-	-	-	Ho 166m	-	-	-	-	-	-	-	-
8	Cr 51	-	-	-	-	-	-	-	-	-	-	-	-	-	-	-	-	-
9	Sb 125	-	-	-	-	-	-	-	-	-	-	-	-	-	-	-	-	-
10	Y 89m	-	-	-	-	-	-	-	-	-	-	-	-	-	-	-	-	-

Table 14: Radionuclides Contributing at least 0.1% of Thermal Power in Zircaloy at Each Decay Period⁶

	Decay Time [years]																	
	0.0	5.0	10.0	15.0	20.0	30.0	40.0	50.0	70.0	100.0	200.0	300.0	500.0	1.0E+03	1.0E+04	1.0E+05	1.0E+06	1.0E+07
1	Zr 95	Co 60	Co 60	Co 60	Co 60	Co 60	Co 60	Co 60	Co 60	Ni 63	Nb 94	Nb 94	Nb 94	Nb 94	Nb 94	Cl 36	Nb 93m	Nb 93m
2	Nb 95	Sb 125	Sb 125	Sb 125	Sb 125	Ni 63	Ni 63	Ni 63	Ni 63	Nb 94	Ni 63	C 14	C 14	C 14	C 14	Nb 93m	Zr 93	Zr 93
3	Sc 46	Te 125m	Te 125m	Te 125m	Ni 63	Sb 125	Nb 94	Nb 94	Nb 94	C 14	C 14	Ni 63	Ni 63	Cl 36	Cl 36	Zr 93	Cl 36	Ta 182
4	Co 60	Sn 119m	Cs 134	-	-	Nb 94	Sn 121	Sn 121	C 14	Sn 121	Ag 108m	Cl 36	Cl 36	Nb 93m	Nb 93m	Nb 94	-	Hf 182
5	Ta 182	Cs 134	-	-	-	H 3	H 3	C 14	Sn 121	Ag 108m	Cl 36	Ag 108m	Ag 108m	Zr 93	Zr 93	Ni 59	-	K 40
6	Ag 110	-	-	-	-	Sn 121	C 14	H 3	Sn 121m	Sn 121m	Sn 121	Nb 93m	Nb 93m	Ag 108m	Ni 59	-	-	-
7	Hf 181	-	-	-	-	-	Sn 121m	Sn 121m	Ag 108m	Cl 36	Nb 93m	Zr 93	Zr 93	Ni 59	-	-	-	-
8	Sn 121	-	-	-	-	-	Sb 125	Ag 108m	H 3	Co 60	Zr 93	Ar 39	Ar 39	Ar 39	-	-	-	-
9	In 113m	-	-	-	-	-	-	Cl 36	Cl 36	Nb 93m	Ar 39	Sn 121	Ni 59	Ni 63	-	-	-	-
10	Re 188	-	-	-	-	-	-	Nb 93m	Nb 93m	Ar 39	Sn 121m	Ni 59	Ho 166m	Ho 166m	-	-	-	-
11	Y 90	-	-	-	-	-	-	Eu 154	Ar 39	Zr 93	Ni 59	Sn 121m	Ag 108	-	-	-	-	-
12	Sb 125	-	-	-	-	-	-	Ar 39	Zr 93	H 3	Ag 108	Ho 166m	-	-	-	-	-	-
13	Cr 51	-	-	-	-	-	-	-	Ni 59	Ni 59	Ho 166m	Ag 108	-	-	-	-	-	-
14	Ag 108	-	-	-	-	-	-	-	Eu 154	-	-	-	-	-	-	-	-	-
15	Sn 119m	-	-	-	-	-	-	-	-	-	-	-	-	-	-	-	-	-
16	Y 89m	-	-	-	-	-	-	-	-	-	-	-	-	-	-	-	-	-
17	Nb 95m	-	-	-	-	-	-	-	-	-	-	-	-	-	-	-	-	-
18	Co 60m	-	-	-	-	-	-	-	-	-	-	-	-	-	-	-	-	-

⁵ Note: At discharge (0.0 years decay), nuclides that are short lived (such that they have zero inventory at 5 years decay) are not included in this list, many of which would contribute to 99.9% of the total gamma power.

⁶ Note: At discharge (0.0 years decay), nuclides that are short lived (such that they have zero inventory at 5 years decay) are not included in this list, many of which would contribute to 99.9% of the total decay heat.

APPENDIX B: REGRESSION TESTING COMPARISON RESULTS

Table 15: Comparison of Total Activity, Thermal Power, Gamma Power, Gamma Emissions, and Neutron Intensity in Fuel to Tait et al. (2000) Results

Decay Period [years]:	0	10	50	100	200	500	1E+03	1E+04	1E+05	1E+06	1E+07
Total Activity per kg U in Fuel Comparison (Bq per kg U)											
New Analysis	5.29E+15	3.87E+12	1.26E+12	4.03E+11	7.84E+10	3.32E+10	2.33E+10	8.61E+09	6.92E+08	2.84E+08	1.83E+08
Tait et al. (2000)	5.32E+15	3.98E+12	1.29E+12	4.07E+11	7.84E+10	3.37E+10	2.36E+10	8.73E+09	6.90E+08	2.78E+08	1.83E+08
Difference ⁷	-0.7%	-2.8%	-2.0%	-0.9%	0.0%	-1.4%	-1.5%	-1.4%	0.3%	2.2%	0.2%
Total Thermal Power per kg U in Fuel Comparison (W per kg U)											
New Analysis	1.37E+03	2.67E-01	1.30E-01	7.06E-02	4.16E-02	2.86E-02	1.98E-02	7.03E-03	4.05E-04	1.48E-04	1.01E-04
Tait et al. (2000)	1.41E+03	2.81E-01	1.32E-01	7.07E-02	4.18E-02	2.90E-02	2.01E-02	7.13E-03	4.10E-04	1.48E-04	1.01E-04
Difference	-2.7%	-5.1%	-1.2%	-0.2%	-0.5%	-1.3%	-1.5%	-1.5%	-1.2%	-0.5%	0.0%
Total Photon Emission per kg U in Fuel Comparison (Photon/s per kg U)											
New Analysis	8.59E+15	1.52E+12	5.61E+11	1.89E+11	3.52E+10	1.22E+10	6.15E+09	5.88E+08	9.93E+07	1.00E+08	6.01E+07
Tait et al. (2000)	7.43E+15	1.95E+12	6.95E+11	2.27E+11	3.86E+10	1.28E+10	6.77E+09	9.74E+08	1.39E+08	1.18E+08	7.42E+07
Difference	15.5%	-21.8%	-19.2%	-16.9%	-8.7%	-4.2%	-9.1%	-39.6%	-28.4%	-15.4%	-19.0%
Total Gamma Power (Photon Energy) per kg U in Fuel Comparison (MeV/s per kg U)											
New Analysis	4.01E+15	6.07E+11	2.16E+11	6.85E+10	7.50E+09	4.82E+08	2.32E+08	2.33E+07	2.18E+07	2.78E+07	2.35E+07
Tait et al. (2000)	2.39E+15	6.70E+11	2.23E+11	7.00E+10	7.50E+09	4.62E+08	2.28E+08	3.11E+07	2.49E+07	2.81E+07	2.39E+07
Difference	67.8%	-9.4%	-3.0%	-2.1%	0.0%	4.5%	1.7%	-25.1%	-12.5%	-1.2%	-1.7%
Total Neutron Intensity per kg U in Fuel Comparison (neutron/s per kg U)											
New Analysis	8.64E+12	6.14E+03	3.39E+03	2.63E+03	2.36E+03	2.07E+03	1.79E+03	7.82E+02	1.66E+02	4.37E+01	1.54E+01
Tait et al. (2000)	3.00E+04	6.21E+03	3.49E+03	2.74E+03	2.47E+03	2.15E+03	1.86E+03	8.05E+02	1.68E+02	4.47E+01	1.58E+01
Difference	2.88E+06	-1.2%	-2.8%	-3.8%	-4.2%	-3.9%	-3.3%	-2.8%	-1.3%	-2.4%	-2.6%
Total Spontaneous Fission and Alpha Neutron Intensity per kg U in Fuel Comparison (neutron/s per kg U)											
New Analysis	3.16E+04	6.14E+03	3.39E+03	2.63E+03	2.36E+03	2.07E+03	1.79E+03	7.82E+02	1.66E+02	4.37E+01	1.54E+01
Tait et al. (2000)	3.00E+04	6.21E+03	3.49E+03	2.74E+03	2.47E+03	2.15E+03	1.86E+03	8.05E+02	1.68E+02	4.47E+01	1.58E+01
Difference	5.4%	-1.2%	-2.8%	-3.8%	-4.2%	-3.9%	-3.3%	-2.8%	-1.2%	-2.4%	-2.6%

⁷ The 'Difference' presented is calculated as (new analysis results – previous analysis results)/previous analysis results.

Table 16: Comparison of Total Activity, Thermal Power, Gamma Power and Intensity of Light Elements in Cladding to Tait et al. (2000) Results

Decay Period [years]:	0	10	50	100	200	500	1E+03	1E+04	1E+05	1E+06	1E+07
Total Activity (Bq per kg Zircaloy)											
New Analysis	4.88E+13	3.06E+10	1.38E+09	7.22E+08	3.89E+08	1.25E+08	8.50E+07	4.94E+07	2.52E+07	1.36E+07	2.27E+05
Tait et al. (2000)	4.33E+13	2.88E+10	4.67E+08	2.17E+08	1.38E+08	7.92E+07	6.86E+07	4.12E+07	2.42E+07	1.54E+07	2.61E+05
Difference	13%	6%	196%	233%	183%	58%	24%	20%	4%	-12%	-13%
Total Thermal Power per kg Zircaloy in Cladding Comparison (W per kg Zr)											
New Analysis	9.96E+00	7.42E-03	4.17E-05	3.74E-06	2.54E-06	1.68E-06	1.49E-06	9.62E-07	1.84E-07	6.07E-08	9.07E-10
Tait et al. (2000)	5.57E+00	8.09E-03	5.03E-05	7.78E-06	4.92E-06	1.99E-06	1.31E-06	8.31E-07	1.34E-07	6.12E-08	1.02E-09
Difference ⁸	79%	-8%	-17%	-52%	-48%	-16%	14%	16%	37%	-1%	-11%
Total Gamma Intensity (Photon Emission) per kg Zircaloy in Cladding Comparison (Photon/s per kg Zr)											
New Analysis	5.27E+13	4.14E+10	1.99E+08	1.49E+07	1.14E+07	9.79E+06	9.17E+06	6.62E+06	1.74E+06	8.97E+05	1.51E+04
Tait et al. (2000)	4.54E+13	4.88E+10	3.26E+08	7.97E+07	5.08E+07	1.94E+07	1.21E+07	8.53E+06	2.62E+06	1.52E+06	2.57E+04
Difference	16%	-15%	-39%	-81%	-78%	-50%	-24%	-22%	-34%	-41%	-41%
Total Gamma Power (Photon Energy) per kg Zircaloy in Cladding Comparison (MeV/s per kg Zr)											
New Analysis	5.35E+13	4.41E+10	2.26E+08	6.28E+06	5.77E+06	5.47E+06	5.19E+06	3.69E+06	2.00E+05	1.48E+04	3.84E+02
Tait et al. (2000)	2.27E+13	4.82E+10	2.93E+08	4.07E+07	2.55E+07	8.97E+06	5.16E+06	3.54E+06	1.88E+05	1.57E+04	3.37E+02
Difference	136%	-8%	-23%	-85%	-77%	-39%	1%	4%	6%	-6%	14%

...

⁸ The 'Difference' presented is calculated as (new analysis results – previous analysis results)/previous analysis results.

APPENDIX C: BUNDLE SCREENING STUDY COMPARISONS

Table 17: Bundle Screening Study – 28-element Relative to 37R Significant Radionuclide Mass per kg U (200 kW, 230 MWh/kgU)

LEGEND		
LOW	-5%	Case 1 Results are LOWER than Case 2 (Reference Case)
MID	0%	No difference in Results
HIGH	5%	Case 1 Results are HIGHER than Case 2 (Reference Case)
#DIV/0!		Inventory of ZERO in Case 2 (Reference Case)
-		Not a significant nuclide at this decay time

Nuclide	Decay Time [years]																	
	0.0	5.0	10.0	15.0	20.0	30.0	40.0	50.0	70.0	100.0	200.0	300.0	500.0	1.00E+03	1.00E+04	1.00E+05	1.00E+06	1.00E+07
Ac 225	0.08%	3.77%	3.37%	3.06%	2.87%	2.56%	2.34%	2.18%	1.97%	1.81%	1.52%	1.45%	1.35%	1.29%	1.17%	0.81%	0.57%	0.57%
Ac 227	5.14%	0.97%	0.58%	0.43%	0.36%	0.27%	0.24%	0.25%	0.23%	0.21%	0.20%	0.20%	0.21%	0.19%	0.20%	0.68%	0.95%	0.96%
Ag 109m	-4.64%	-	-	-	-	-	-	-	-	-	-	-	-	-	-	-	-	-
Ag 110	-4.51%	-	-	-	-	-	-	-	-	-	-	-	-	-	-	-	-	-
Am 241	-	0.69%	0.43%	0.34%	0.31%	0.23%	0.24%	0.21%	0.23%	0.18%	0.20%	0.15%	0.17%	0.19%	-	-	-	-
Am 243	-	-	-	-	-	-	-	-	-	-	-	0.41%	0.41%	0.41%	0.42%	-	-	-
At 217	-	-	-	-	-	-	-	-	-	-	-	-	-	-	-	0.81%	0.55%	0.56%
Ba 137m	-0.09%	-0.05%	-0.07%	-0.05%	-0.04%	-0.06%	-0.06%	-0.06%	-0.05%	-0.04%	-0.06%	-0.06%	-0.04%	-	-	-	-	-
Bi 210	-3.53%	5.17%	5.17%	5.20%	5.16%	5.10%	4.95%	4.66%	3.40%	0.64%	-1.30%	-1.24%	-1.15%	-0.94%	-0.84%	-0.70%	-0.05%	0.00%
Bi 211	-	-	-	-	-	-	-	-	-	-	-	-	-	-	0.21%	0.66%	0.97%	0.96%
Bi 212	-	-	-	-	-	-	-	-	-	-	-	-0.12%	-	-	-	-	-	-
Bi 213	-	-	-	-	-	-	-	-	-	-	-	-	-	-	1.17%	0.80%	0.56%	0.55%
Bi 214	-	-	-	-	-	-	-	-	-	-	-	-	-	-	-0.85%	-0.73%	-0.07%	0.00%
C 14	0.06%	0.06%	0.06%	0.06%	0.06%	0.06%	0.06%	0.06%	0.06%	0.05%	0.06%	0.05%	0.06%	0.06%	0.08%	0.07%	#DIV/0!	#DIV/0!
Ca 41	-0.44%	-0.44%	-0.44%	-0.44%	-0.44%	-0.43%	-0.43%	-0.43%	-0.46%	-0.42%	-0.43%	-0.43%	-0.42%	-0.45%	-0.44%	-0.44%	-0.44%	#DIV/0!
Ce 141	-4.41%	-	-	-	-	-	-	-	-	-	-	-	-	-	-	-	-	-
Ce 144	-3.43%	-3.44%	-	-	-	-	-	-	-	-	-	-	-	-	-	-	-	-
Cl 36	-0.43%	-0.43%	-0.45%	-0.45%	-0.45%	-0.46%	-0.46%	-0.46%	-0.46%	-0.43%	-0.44%	-0.42%	-0.44%	-0.45%	-0.44%	-0.40%	-0.44%	-0.44%
Cm 242	1.42%	2.07%	-	-	-	-	-	-	-	-	-	-	-	-	-	-	-	-
Cm 244	1.44%	1.46%	1.42%	1.46%	1.42%	1.45%	1.45%	1.44%	1.46%	1.46%	1.46%	-	-	-	-	-	-	-
Cm 246	-	-	1.92%	1.92%	1.94%	1.93%	1.93%	1.92%	1.92%	1.93%	1.93%	1.92%	1.92%	1.93%	1.92%	-	-	-
Co 60	-	-0.80%	-0.80%	-	-	-	-	-	-	-	-	-	-	-	-	-	-	-
Cs 134	-0.47%	-0.50%	-0.49%	-0.48%	-0.47%	-	-	-	-	-	-	-	-	-	-	-	-	-
Cs 135	4.20%	4.18%	4.18%	4.18%	4.18%	4.18%	4.18%	4.18%	4.18%	4.18%	4.18%	4.19%	4.18%	4.17%	4.17%	4.18%	4.17%	4.19%
Cs 137	-	-0.07%	-0.03%	-0.06%	-0.07%	-0.05%	-0.07%	-0.06%	-0.05%	-0.05%	-0.07%	-	-	-	-	-	-	-
Eu 154	-	1.28%	1.29%	1.29%	1.29%	1.30%	1.27%	1.29%	1.33%	-	-	-	-	-	-	-	-	-
Eu 155	-	0.19%	-	-	-	-	-	-	-	-	-	-	-	-	-	-	-	-
Fr 221	-	-	-	-	-	-	-	-	-	-	-	-	-	-	1.18%	0.81%	0.56%	0.56%

Nuclide	Decay Time [years]																	
	0.0	5.0	10.0	15.0	20.0	30.0	40.0	50.0	70.0	100.0	200.0	300.0	500.0	1.00E+03	1.00E+04	1.00E+05	1.00E+06	1.00E+07
I 129	0.33%	0.27%	0.27%	0.27%	0.27%	0.27%	0.27%	0.27%	0.27%	0.27%	0.29%	0.29%	0.30%	0.30%	0.30%	0.30%	0.29%	0.29%
Kr 85	-	-0.34%	-0.35%	-0.32%	-0.35%	-0.34%	-0.34%	-0.35%	-	-	-	-	-	-	-	-	-	-
Nb 93m	-	-	-	-	-	-	-	-	-	-	-	-	-	-	0.14%	0.12%	-	-
Nb 94	-	-	-	-	-	-	-	-	-	-	-	-	-	-	1.35%	-	-	-
Nb 95	-4.50%	-	-	-	-	-	-	-	-	-	-	-	-	-	-	-	-	-
Np 237	3.31%	3.17%	3.11%	3.05%	2.97%	2.77%	2.59%	2.42%	2.11%	1.79%	1.25%	1.00%	0.79%	0.63%	0.56%	0.57%	0.51%	0.57%
Np 238	-0.64%	-	-	-	-	-	-	-	-	-	-	-	-	-	-	-	-	-
Np 239	-4.45%	-	-	-	-	-	-	-	-	-	0.42%	0.41%	0.41%	0.41%	0.40%	-	-	-
Np 240	-8.80%	-	-	-	-	-	-	-	-	-	-	-	-	-	-	-	-	-
Np 240m	-8.83%	-	-	-	-	-	-	-	-	-	-	-	-	-	-	-	-	-
Pa 231	0.21%	0.21%	0.19%	0.19%	0.19%	0.19%	0.21%	0.19%	0.19%	0.20%	0.21%	0.20%	0.20%	0.19%	0.21%	0.67%	0.94%	0.97%
Pa 233	-3.42%	3.18%	3.11%	3.05%	2.96%	2.77%	2.59%	2.41%	2.13%	1.81%	1.26%	1.00%	0.79%	0.63%	0.55%	0.55%	0.55%	0.55%
Pa 234	-	-	-	-	-	-	-	-	-	-	-	-	-	-	-0.02%	-0.02%	-0.02%	0.00%
Pa 234m	-	-	-	-	-	-	-	-	-	-	-	-	-	-	0.00%	0.00%	-0.01%	0.01%
Pb 209	-	-	-	-	-	-	-	-	-	-	-	-	-	-	-	-	0.56%	-
Pb 210	5.41%	5.18%	5.18%	5.18%	5.19%	5.11%	4.95%	4.68%	3.41%	0.63%	-1.31%	-1.26%	-1.14%	-0.94%	-0.86%	-0.70%	-0.07%	-0.01%
Pb 211	-	-	-	-	-	-	-	-	-	-	-	-	-	-	0.21%	0.69%	-	-
Pb 212	-	-	-	-	-	-	-	-	-	-	-0.13%	-0.12%	-	-	-	-	-	-
Pb 214	-	-	-	-	-	-	-	-	-	-	-	-	-	-	-0.84%	-0.73%	-0.07%	0.00%
Pd 107	-0.03%	-0.04%	-0.04%	-0.04%	-0.04%	-0.04%	-0.04%	-0.05%	-0.05%	-0.05%	-0.05%	-0.03%	-0.03%	-0.03%	-0.03%	-0.03%	-0.04%	-0.05%
Pm 147	-	-1.11%	-1.12%	-1.11%	-	-	-	-	-	-	-	-	-	-	-	-	-	-
Pm 148	-5.18%	-	-	-	-	-	-	-	-	-	-	-	-	-	-	-	-	-
Pm 148m	-0.42%	-	-	-	-	-	-	-	-	-	-	-	-	-	-	-	-	-
Po 210	-3.13%	2.63%	5.20%	5.18%	5.17%	5.12%	4.98%	4.66%	3.40%	0.63%	-1.31%	-1.26%	-1.14%	-0.95%	-0.86%	-0.73%	-0.06%	0.01%
Po 212	-	0.11%	-0.09%	-0.11%	-0.12%	-0.12%	-0.13%	-0.12%	-0.12%	-0.14%	-0.10%	-	-	-	-	-	-	-
Po 213	-	-	-	-	-	-	-	-	-	-	-	-	-	-	-	0.80%	0.57%	0.61%
Po 214	-	-	-	-	-	-	-	-	-	-	-	-	-	-	-	-0.71%	-0.06%	0.00%
Po 215	-	-	-	-	-	-	-	-	-	-	-	-	-	-	-	0.67%	0.96%	0.97%
Po 216	-	0.15%	-0.11%	-0.11%	-0.15%	-0.14%	-0.14%	-0.11%	-0.12%	-0.12%	-0.13%	-	-	-	-	-	-	-
Po 218	-	-	-	-	-	-	-	-	-	-	-	-	-	-	-	-0.73%	-0.07%	0.00%
Pr 144	-3.47%	-3.44%	-3.43%	-	-	-	-	-	-	-	-	-	-	-	-	-	-	-
Pu 238	4.75%	4.04%	4.05%	4.04%	4.03%	4.04%	4.04%	4.04%	4.04%	4.04%	4.03%	4.05%	4.10%	-	-	-	-	-
Pu 239	1.42%	1.36%	1.36%	1.39%	1.37%	1.38%	1.38%	1.37%	1.39%	1.36%	1.35%	1.38%	1.39%	1.37%	1.37%	1.40%	-	-
Pu 240	-0.23%	-0.21%	-0.24%	-0.21%	-0.25%	-0.24%	-0.24%	-0.24%	-0.23%	-0.22%	-0.24%	-0.21%	-0.21%	-0.21%	-0.22%	-	-	-
Pu 241	-	0.02%	0.00%	0.04%	0.05%	0.05%	-	-	-	-	-	-	-	-	-	-	-	-
Pu 242	-1.58%	-1.59%	-1.58%	-1.59%	-1.58%	-1.58%	-1.58%	-1.58%	-1.58%	-1.59%	-1.58%	-1.59%	-1.59%	-1.59%	-1.59%	-1.59%	-1.58%	-
Ra 223	5.51%	0.97%	0.61%	0.45%	0.37%	0.29%	0.26%	0.23%	0.22%	0.20%	0.19%	0.19%	0.19%	0.20%	0.21%	0.66%	0.94%	0.97%
Ra 224	3.26%	0.10%	-0.07%	-0.11%	-0.12%	-0.12%	-0.14%	-0.11%	-0.11%	-0.08%	-0.13%	-0.10%	-0.11%	-0.12%	-0.06%	-0.03%	-0.04%	-0.09%
Ra 225	-0.28%	3.75%	3.38%	3.09%	2.86%	2.55%	2.33%	2.21%	1.98%	1.78%	1.53%	1.43%	1.35%	1.28%	1.18%	0.83%	0.55%	0.56%

Table 18: Bundle Screening Study – 28-element Relative to 37R Significant Element Mass per kg U (200 kW, 230 MWh/kgU)

Element	Decay Time [years]																	
	0.0	5.0	10.0	15.0	20.0	30.0	40.0	50.0	70.0	100.0	200.0	300.0	500.0	1.00E+03	1.00E+04	1.00E+05	1.00E+06	1.00E+07
Ac	-	-	-	-	-	-	-	-	-	-	-	-	-	-	0.19%	0.67%	0.95%	0.96%
Ag	-0.18%	-0.16%	-0.13%	-0.13%	-0.13%	-0.13%	-0.13%	-0.13%	-0.13%	-0.16%	-0.14%	-0.14%	-0.13%	-0.13%	-0.15%	-0.13%	-0.12%	-0.08%
Am	-	0.66%	0.44%	0.37%	0.27%	0.25%	0.23%	0.18%	0.19%	0.20%	0.20%	0.21%	0.21%	0.23%	0.42%	-	-	-
As	-0.04%	-	-	-	-	-	-	-	-	-	-	-	-	-	-	-	-	-
At	-	-	-	-	-	-	-	-	-	-	-	-	-	-	-	0.79%	0.54%	0.41%
Ba	0.17%	0.22%	0.20%	0.16%	0.17%	0.14%	0.14%	0.14%	0.11%	0.10%	0.11%	0.11%	0.11%	-	-	-	-	-
Bi	-0.01%	-0.01%	-0.01%	-0.01%	-0.01%	-0.01%	-0.01%	-0.01%	-0.01%	-0.01%	-0.01%	-0.01%	-0.01%	0.00%	0.09%	0.71%	0.60%	0.56%
Br	-0.02%	-0.02%	-0.02%	-0.02%	-0.02%	-0.02%	-0.02%	-0.02%	-0.02%	-0.02%	-0.02%	-0.02%	-0.01%	-0.02%	-0.01%	-0.01%	0.00%	0.00%
Cd	0.24%	0.19%	0.19%	0.19%	0.19%	0.19%	0.19%	0.19%	0.19%	0.19%	0.19%	0.19%	0.19%	0.19%	0.19%	0.19%	0.19%	0.19%
Ce	-0.46%	0.05%	-	-	-	-	-	-	-	-	-	-	-	-	-	-	-	-
Cm	-	1.49%	1.50%	1.49%	1.48%	1.53%	1.59%	1.67%	1.79%	-	-	-	-	-	-	-	-	-
Co	-	-0.05%	-0.03%	-	-	-	-	-	-	-	-	-	-	-	-	-	-	-
Cs	0.41%	0.43%	0.45%	0.48%	0.50%	0.55%	0.58%	0.61%	0.69%	0.72%	0.77%	-	-	-	-	-	-	-
Eu	0.37%	0.43%	0.42%	0.41%	0.38%	0.36%	0.40%	0.38%	0.38%	-	-	-	-	-	-	-	-	-
Fr	-	-	-	-	-	-	-	-	-	-	-	-	-	-	1.16%	0.81%	0.56%	0.57%
Ge	0.15%	-	-	-	-	-	-	-	-	-	-	-	-	-	-	-	-	-
Hg	0.06%	0.07%	0.05%	0.05%	0.05%	0.05%	0.05%	0.05%	0.05%	0.05%	0.05%	0.05%	0.05%	0.05%	0.05%	0.05%	0.05%	0.05%
I	0.09%	0.25%	0.25%	0.25%	0.25%	0.25%	0.25%	0.25%	0.25%	0.25%	0.25%	0.25%	0.25%	0.25%	0.27%	0.26%	0.27%	0.27%
In	-0.09%	-	-	-	-	-	-	-	-	-	-	-	-	-	-	-	-	-
Kr	0.11%	0.11%	0.12%	0.13%	0.13%	0.13%	0.14%	0.15%	-	-	-	-	-	-	-	-	-	-
La	0.09%	-	-	-	-	-	-	-	-	-	-	-	-	-	-	-	-	-
Mo	0.24%	0.10%	0.10%	0.10%	0.10%	0.10%	0.10%	0.10%	0.10%	0.10%	0.10%	0.10%	0.10%	0.10%	0.10%	0.10%	0.10%	0.10%
Nb	-4.09%	-	-	-	-	-	-	-	-	-	-	-	-	-	0.04%	0.09%	-	-
Nd	0.50%	0.11%	0.11%	0.11%	0.11%	0.11%	0.11%	0.11%	0.11%	0.11%	0.11%	0.11%	0.11%	0.11%	0.11%	0.11%	0.11%	0.11%
Np	-0.40%	-	-	-	-	-	-	-	-	-	1.25%	1.00%	0.79%	0.63%	0.56%	0.57%	0.51%	0.57%
Pa	-	-	-	-	-	-	-	-	-	-	-	-	0.20%	0.19%	0.21%	0.67%	0.94%	0.97%
Pb	-	-	-	-	-	-	-	-	-	-	-0.01%	-0.01%	-	-	-0.02%	-0.49%	-0.24%	-0.01%
Pd	0.46%	0.10%	0.10%	0.10%	0.10%	0.10%	0.10%	0.10%	0.10%	0.10%	0.10%	0.10%	0.10%	0.10%	0.09%	0.09%	0.09%	0.09%
Pm	-1.04%	-1.11%	-1.12%	-1.11%	-	-	-	-	-	-	-	-	-	-	-	-	-	-
Po	-	2.61%	5.05%	5.00%	4.98%	4.89%	4.72%	4.41%	3.25%	0.81%	-1.24%	-1.25%	-	-	-	-0.73%	-0.07%	-0.01%
Pr	0.24%	0.09%	0.09%	-	-	-	-	-	-	-	-	-	-	-	-	-	-	-
Pu	-	0.73%	0.75%	0.74%	0.77%	0.78%	0.77%	0.78%	0.78%	0.79%	0.78%	0.79%	0.81%	0.79%	0.97%	0.24%	-1.58%	-
Ra	-	-	-0.08%	-0.12%	-0.14%	-0.13%	-0.13%	-0.17%	-0.19%	-0.32%	-0.98%	-	-	-	-0.86%	-0.70%	-0.08%	-0.01%
Rb	0.13%	-	-	-	-	-	-	-	-	-	-	-	-	-	-	-	-	-
Rh	0.44%	0.01%	0.01%	0.01%	0.01%	0.01%	0.01%	0.01%	0.01%	0.01%	0.01%	0.01%	0.01%	0.01%	0.01%	0.01%	0.01%	0.01%
Rn	-	-	-0.09%	-0.11%	-0.13%	-0.12%	-0.12%	-0.12%	-0.14%	-0.14%	-0.25%	-	-	-	-0.85%	-0.72%	-0.05%	0.01%
Ru	-0.16%	0.12%	0.14%	0.13%	0.13%	0.13%	0.13%	0.13%	0.13%	0.14%	0.12%	0.13%	0.13%	0.13%	0.14%	0.13%	0.11%	0.11%
Sb	-0.01%	0.46%	0.66%	0.74%	0.77%	0.78%	0.78%	0.80%	0.76%	0.77%	0.74%	0.76%	0.78%	0.79%	0.79%	0.79%	0.79%	0.79%

Element	Decay Time [years]																	
	0.0	5.0	10.0	15.0	20.0	30.0	40.0	50.0	70.0	100.0	200.0	300.0	500.0	1.00E+03	1.00E+04	1.00E+05	1.00E+06	1.00E+07
Se	0.10%	0.10%	0.10%	0.10%	0.10%	0.10%	0.10%	0.10%	0.10%	0.10%	0.06%	0.06%	0.06%	0.06%	0.07%	0.10%	0.09%	0.09%
Sn	0.53%	-	-	-	-	-	-	-	-	-	-	-	-	-	0.54%	0.55%	-	-
Sr	-0.13%	0.00%	0.03%	0.02%	0.03%	0.05%	0.01%	0.06%	0.06%	0.07%	0.09%	-	-	-	-	-	-	-
Tc	0.06%	0.05%	0.05%	0.05%	0.05%	0.05%	0.05%	0.05%	0.05%	0.02%	0.06%	0.04%	0.05%	0.04%	0.01%	0.00%	0.03%	4.38%
Te	0.01%	0.05%	0.07%	0.04%	0.07%	0.06%	0.06%	0.06%	0.06%	0.06%	0.06%	0.06%	0.06%	0.05%	0.04%	0.08%	0.04%	0.06%
Th	-	-	-0.05%	-0.05%	-0.05%	-0.05%	-0.05%	-0.05%	-0.05%	-0.05%	-0.04%	-	-	-0.05%	-0.05%	-0.05%	-0.05%	-0.08%
Tl	-	-	-	-	-	-0.01%	0.00%	0.00%	0.00%	0.00%	0.00%	0.00%	0.00%	-	0.00%	0.00%	0.00%	0.00%
U	0.00%	-	0.00%	-0.01%	-0.01%	-0.01%	-0.01%	-0.01%	-0.01%	0.00%	0.00%	0.00%	-	-0.01%	0.00%	0.00%	-0.01%	-0.01%
W	0.02%	0.04%	0.04%	0.04%	0.04%	0.04%	0.04%	0.04%	0.04%	0.04%	0.04%	0.04%	0.04%	0.04%	0.04%	0.04%	0.04%	0.04%
Xe	-0.08%	-	-	-	-	-	-	-	-	-	-	-	-	-	-	-	-	-
Y	-0.06%	0.10%	0.10%	0.09%	0.09%	0.09%	0.10%	0.10%	0.10%	0.10%	0.10%	0.10%	-	-	-	-	-	-
Zr	0.09%	-	-	-	-	-	-	-	-	-	-	-	-	-	-	-	-	-

Table 19: Bundle Type Screening Study – Comparison of Total Thermal Power per kg U in Different Bundle Types relative to 37R Bundle (200 kW, 230 MWh/kgU)

Bundle	Decay Period [years]																	
	0	5	10	15	20	30	40	50	70	100	200	300	500	1 E3	1 E4	1 E5	1 E6	1 E7
28	-4.3%	-0.6%	0.0%	0.1%	0.1%	0.1%	0.1%	0.2%	0.2%	0.3%	0.3%	0.3%	0.3%	0.3%	0.6%	0.9%	0.1%	0.0%
37M	0.6%	0.1%	0.1%	0.0%	0.0%	0.1%	0.0%	0.0%	0.0%	0.0%	0.1%	0.1%	0.1%	0.0%	0.0%	-0.1%	0.0%	0.0%

Table 20: Bundle Type Screening Study – Comparison of Total Gamma Power per kg U in Different Bundle Types Relative to 37R Bundle (200 kW, 230 MWh/kgU)

Bundle	Decay Period [years]																	
	0	5	10	15	20	30	40	50	70	100	200	300	500	1 E3	1 E4	1 E5	1 E6	1 E7
28	-4.3%	-0.4%	-0.1%	0.0%	0.0%	-0.1%	0.0%	-0.1%	0.0%	0.0%	0.0%	0.1%	0.2%	0.2%	0.2%	-0.2%	0.0%	0.0%
37M	0.7%	0.1%	0.1%	0.1%	0.1%	0.1%	0.1%	0.1%	0.1%	0.1%	0.1%	0.1%	0.1%	0.1%	-0.1%	-0.1%	0.0%	0.0%

Table 21: Bundle Type Screening Study – Comparison of Total Neutron Power per kg U in Different Bundle Types Relative to 37R Bundle (200 kW, 230 MWh/kgU)

Bundle	Decay Period [years]																	
	0	5	10	15	20	30	40	50	70	100	200	300	500	1 E3	1 E4	1 E5	1 E6	1 E7
28	-3.8%	1.1%	1.0%	0.9%	0.9%	0.7%	0.6%	0.5%	0.3%	0.1%	-0.1%	-0.1%	-0.2%	-0.2%	-0.3%	-1.4%	-1.0%	0.0%
37M	0.6%	-0.5%	-0.5%	-0.4%	-0.4%	-0.3%	-0.2%	-0.2%	-0.1%	0.0%	0.1%	0.1%	0.1%	0.1%	0.1%	0.0%	0.0%	0.0%

Table 22: Bundle Type Screening Study – 37M Relative to 37R Significant Radionuclide Mass per kg U (200 kW, 230 MWh/kgU)

LEGEND		
LOW	-5%	Case 1 Results are LOWER than Case 2 (Reference Case)
MID	0%	No difference in Results
HIGH	5%	Case 1 Results are HIGHER than Case 2 (Reference Case)
#DIV/0!		Inventory of ZERO in Case 2 (Reference Case)
-		Not a significant nuclide at this decay time

Nuclide	Decay Time [years]																	
	0.0	5.0	10.0	15.0	20.0	30.0	40.0	50.0	70.0	100.0	200.0	300.0	500.0	1.00E+03	1.00E+04	1.00E+05	1.00E+06	1.00E+07
Ac 225	0.03%	-0.47%	-0.41%	-0.38%	-0.32%	-0.27%	-0.23%	-0.22%	-0.18%	-0.16%	-0.13%	-0.09%	-0.08%	-0.07%	-0.05%	0.01%	0.03%	0.04%
Ac 227	-0.85%	-0.18%	-0.13%	-0.10%	-0.09%	-0.09%	-0.09%	-0.08%	-0.05%	-0.07%	-0.05%	-0.07%	-0.07%	-0.07%	-0.07%	-0.14%	-0.17%	-0.16%
Ag 109m	0.70%	-	-	-	-	-	-	-	-	-	-	-	-	-	-	-	-	-
Ag 110	0.63%	-	-	-	-	-	-	-	-	-	-	-	-	-	-	-	-	-
Am 241	-	0.02%	0.06%	0.07%	0.12%	0.09%	0.11%	0.09%	0.09%	0.09%	0.09%	0.08%	0.09%	0.09%	-	-	-	-
Am 243	-	-	-	-	-	-	-	-	-	-	-	-0.35%	-0.35%	-0.36%	-0.35%	-	-	-
At 217	-	-	-	-	-	-	-	-	-	-	-	-	-	-	-	0.00%	0.04%	0.04%
Ba 137m	0.06%	0.06%	0.06%	0.03%	0.08%	0.05%	0.08%	0.06%	0.06%	0.06%	0.06%	0.06%	0.07%	-	-	-	-	-
Bi 210	0.57%	-0.68%	-0.66%	-0.66%	-0.66%	-0.66%	-0.64%	-0.64%	-0.51%	-0.30%	-0.14%	-0.13%	-0.13%	-0.14%	-0.15%	-0.13%	0.00%	-0.04%
Bi 211	-	-	-	-	-	-	-	-	-	-	-	-	-	-	-0.06%	-0.15%	-0.16%	-0.16%
Bi 212	-	-	-	-	-	-	-	-	-	-	-	0.05%	-	-	-	-	-	-
Bi 213	-	-	-	-	-	-	-	-	-	-	-	-	-	-	-0.07%	-0.01%	0.05%	0.03%
Bi 214	-	-	-	-	-	-	-	-	-	-	-	-	-	-	-0.14%	-0.14%	-0.02%	-0.01%
C 14	0.03%	0.03%	0.03%	0.02%	0.03%	0.03%	0.03%	0.03%	0.03%	0.03%	0.03%	0.03%	0.03%	0.03%	0.06%	0.04%	#DIV/0!	#DIV/0!
Ca 41	0.12%	0.12%	0.13%	0.11%	0.10%	0.12%	0.13%	0.12%	0.10%	0.12%	0.12%	0.12%	0.12%	0.12%	0.13%	0.13%	0.13%	#DIV/0!
Ce 141	0.67%	-	-	-	-	-	-	-	-	-	-	-	-	-	-	-	-	-
Ce 144	0.53%	0.52%	-	-	-	-	-	-	-	-	-	-	-	-	-	-	-	-
Cl 36	0.13%	0.13%	0.13%	0.13%	0.13%	0.13%	0.13%	0.13%	0.11%	0.12%	0.12%	0.13%	0.12%	0.12%	0.13%	0.14%	0.12%	0.13%
Cm 242	-0.24%	-0.31%	-	-	-	-	-	-	-	-	-	-	-	-	-	-	-	-
Cm 244	-0.71%	-0.70%	-0.72%	-0.70%	-0.71%	-0.69%	-0.73%	-0.71%	-0.69%	-0.72%	-0.69%	-	-	-	-	-	-	-
Cm 246	-	-	-1.22%	-1.22%	-1.22%	-1.22%	-1.22%	-1.23%	-1.23%	-1.22%	-1.22%	-1.23%	-1.23%	-1.21%	-1.26%	-	-	-
Co 60	-	0.17%	0.17%	-	-	-	-	-	-	-	-	-	-	-	-	-	-	-
Cs 134	0.16%	0.15%	0.15%	0.16%	0.14%	-	-	-	-	-	-	-	-	-	-	-	-	-
Cs 135	-0.55%	-0.56%	-0.56%	-0.56%	-0.56%	-0.56%	-0.56%	-0.56%	-0.56%	-0.56%	-0.56%	-0.55%	-0.54%	-0.56%	-0.55%	-0.56%	-0.55%	-0.54%
Cs 137	-	0.06%	0.07%	0.06%	0.04%	0.05%	0.06%	0.05%	0.07%	0.06%	0.06%	-	-	-	-	-	-	-
Eu 154	-	-0.05%	-0.04%	-0.06%	-0.05%	-0.07%	-0.05%	-0.05%	-0.04%	-	-	-	-	-	-	-	-	-
Eu 155	-	0.04%	-	-	-	-	-	-	-	-	-	-	-	-	-	-	-	-
Fr 221	-	-	-	-	-	-	-	-	-	-	-	-	-	-	-0.05%	0.00%	0.04%	0.04%
I 129	0.00%	0.01%	0.01%	0.01%	0.01%	0.01%	0.01%	0.01%	0.01%	0.01%	0.03%	0.03%	0.03%	0.03%	0.01%	0.01%	0.00%	0.01%
Kr 85	-	0.11%	0.11%	0.14%	0.10%	0.11%	0.11%	0.08%	-	-	-	-	-	-	-	-	-	-
Nb 93m	-	-	-	-	-	-	-	-	-	-	-	-	-	-	0.09%	0.08%	-	-

APPENDIX D: RADIONUCLIDE HALF-LIVES

The half-life data included in the libraries used with the SCALE 6.1.3 version of the ORIGEN-S code are presented in this appendix. The half-life data are based on ENDF/B-VII.1 decay data. There are some nuclides for which the half-life is significantly different than the half-life used in reference in Tait et al. (2000), which used decay data based on ENDF/B-VI and ENSDF.

Table 24: Actinide Half-Lives

Nuclide	Half-Life [s]	Nuclide	Half-Life [s]	Nuclide	Half-Life [s]	Nuclide	Half-Life [s]
Hg 206	4.99E+02	At 217	3.23E-02	U 232	2.17E+09	Cm 240	2.33E+06
		At 218	1.50E+00	U 233	5.02E+12	Cm 241	2.83E+06
Tl 206	2.52E+02			U 234	7.75E+12	Cm 242	1.41E+07
Tl 207	2.86E+02	Rn 217	1.00E-03	U 235	2.22E+16	Cm 243	9.18E+08
Tl 208	1.83E+02	Rn 218	3.50E-02	U 236	7.39E+14	Cm 244	5.72E+08
Tl 209	1.32E+02	Rn 219	3.96E+00	U 237	5.83E+05	Cm 245	2.68E+11
Tl 210	7.80E+01	Rn 220	5.56E+01	U 238	1.41E+17	Cm 246	1.50E+11
		Rn 222	3.30E+05	U 240	5.08E+04	Cm 247	4.92E+14
Pb 204	4.40E+24					Cm 248	1.10E+13
Pb 205	5.46E+14	Fr 221	2.94E+02	Np 235	3.42E+07	Cm 250	2.62E+11
Pb 209	1.17E+04	Fr 223	1.32E+03	Np 236	4.83E+12		
Pb 210	7.01E+08			Np 237	6.77E+13	Bk 247	4.35E+10
Pb 211	2.17E+03	Ra 223	9.88E+05	Np 238	1.83E+05	Bk 248	2.84E+08
Pb 212	3.83E+04	Ra 224	3.16E+05	Np 239	2.04E+05	Bk 249	2.76E+07
Pb 214	1.61E+03	Ra 225	1.29E+06	Np 240	3.71E+03	Bk 250	1.16E+04
		Ra 226	5.05E+10	Np 240m	4.33E+02		
Bi 207	9.96E+08	Ra 228	1.81E+08			Cf 248	2.88E+07
Bi 208	1.16E+13			Pu 236	9.02E+07	Cf 249	1.11E+10
Bi 209	6.00E+26	Ac 225	8.64E+05	Pu 237	3.94E+06	Cf 250	4.13E+08
Bi 210	4.33E+05	Ac 227	6.87E+08	Pu 238	2.77E+09	Cf 251	2.83E+10
Bi 210m	9.59E+13	Ac 228	2.21E+04	Pu 239	7.61E+11	Cf 252	8.35E+07
Bi 211	1.28E+02			Pu 240	2.07E+11	Cf 254	5.23E+06
Bi 212	3.63E+03	Th 227	1.61E+06	Pu 241	4.51E+08		
Bi 213	2.74E+03	Th 228	6.03E+07	Pu 242	1.18E+13	Es 252	4.08E+07
Bi 214	1.19E+03	Th 229	2.32E+11	Pu 243	1.78E+04	Es 254	2.38E+07
		Th 230	2.38E+12	Pu 244	2.56E+15	Es 255	3.44E+06
Po 208	9.15E+07	Th 231	9.19E+04	Pu 246	9.37E+05		
Po 209	3.22E+09	Th 232	4.43E+17			Am 241	1.37E+10
Po 210	1.20E+07	Th 234	2.08E+06	Am 242m	4.45E+09	Am 242	5.77E+04
Po 211	5.16E-01			Am 243	2.33E+11	Am 244	3.64E+04
Po 212	1.00E-03	Pa 231	1.03E+12	Am 245	7.38E+03	Am 246m	1.50E+03
Po 213	1.00E-03	Pa 232	1.14E+05				
Po 214	1.00E-03	Pa 233	2.33E+06				
Po 215	1.78E-03	Pa 234	2.41E+04				
Po 216	1.45E-01	Pa 234m	6.95E+01				
Po 218	1.86E+02						

Table 25: Fission Product Half-Lives

Nuclide	Half-Life [s]	Nuclide	Half-Life [s]	Nuclide	Half-Life [s]	Nuclide	Half-Life [s]	Nuclide	Half-Life [s]	Nuclide	Half-Life [s]
H 3	3.89E+08	Zr 88	7.21E+06	Rh 101	1.04E+08	Sn 113	9.94E+06	Cs 134	6.52E+07	Sm 145	2.94E+07
		Zr 93	4.83E+13	Rh 102	1.79E+07	Sn 119m	2.53E+07	Cs 135	7.26E+13	Sm 146	3.25E+15
Ga 68	4.06E+03			Rh 102m	1.18E+08	Sn 121	9.73E+04	Cs 137	9.49E+08	Sm 147	3.35E+18
		Zr 95	5.53E+06	Rh 103m	3.37E+03	Sn 121m	1.39E+09			Sm 148	2.21E+23
Ge 68	2.34E+07	Zr 96	6.31E+26	Rh 106	3.01E+01	Sn 123	1.12E+07	Ba 133	3.32E+08	Sm 151	2.84E+09
Ge 73m	4.99E-01					Sn 126	7.26E+12	Ba 137m	1.53E+02		
		Nb 91	2.15E+10	Pd 107	2.05E+14					Eu 149	8.04E+06
As 73	6.94E+06	Nb 91m	5.26E+06			Sb 124	5.20E+06	La 137	1.89E+12	Eu 152	4.27E+08
		Nb 92	1.10E+15	Ag 105	3.57E+06	Sb 125	8.71E+07	La 138	3.22E+18	Eu 154	2.71E+08
Se 75	1.03E+07	Nb 93m	5.09E+08	Ag 108	1.43E+02	Sb 126m	1.15E+03			Eu 155	1.50E+08
Se 79	9.31E+12	Nb 94	6.41E+11	Ag 108m	1.38E+10	Sb 126	1.07E+06	Ce 139	1.19E+07		
		Nb 95	3.02E+06	Ag 109m	3.96E+01			Ce 141	2.81E+06	Gd 151	1.07E+07
Kr 81	7.23E+12	Nb 95m	3.12E+05	Ag 110	2.46E+01	Te 121	1.66E+06	Ce 144	2.46E+07	Gd 152	3.41E+21
Kr 83m	6.59E+03			Ag 110m	2.16E+07	Te 121m	1.42E+07			Gd 153	2.08E+07
Kr 85	3.39E+08	Mo 93	1.26E+11			Te 123m	1.03E+07	Pr 144	1.04E+03		
		Mo 100	2.30E+26	Cd 109	3.99E+07	Te 125m	4.96E+06	Pr 144m	4.32E+02	Tb 157	2.24E+09
Rb 83	7.45E+06			Cd 113	2.54E+23	Te 127m	9.42E+06			Tb 158	5.68E+09
Rb 84	2.84E+06	Tc 95m	5.27E+06	Cd 113m	4.45E+08	Te 127	3.37E+04	Nd 144	7.23E+22	Tb 160	6.25E+06
Rb 87	1.52E+18	Tc 95	7.20E+04	Cd 115m	3.85E+06	Te 128	2.78E+26	Nd 150	2.49E+26		
		Tc 97m	7.86E+06	Cd 116	9.78E+26	Te 129	4.18E+03			Dy 159	1.25E+07
		Tc 97	1.33E+14			Te 129m	2.90E+06	Pm 143	2.29E+07		
Sr 85	5.60E+06	Tc 98	1.33E+14	In 113m	5.97E+03			Pm 144	3.14E+07	Ho 163	1.44E+11
Sr 89	4.37E+06	Tc 99	6.66E+12	In 114m	4.28E+06	I 125	5.13E+06	Pm 145	5.59E+08	Ho 166m	3.79E+10
Sr 90	9.09E+08			In 114	7.19E+01	I 129	4.95E+14	Pm 146	1.75E+08		
		Ru 103	3.39E+06	In 115m	1.61E+04			Pm 147	8.28E+07	Tm 168	8.04E+06
Y 88	9.21E+06	Ru 106	3.21E+07	In 115	1.39E+22	Xe 127	3.14E+06	Pm 148	4.64E+05	Tm 170	1.11E+07
Y 89m	1.57E+01							Pm 148m	3.57E+06	Tm 171	6.06E+07
Y 90	2.30E+05										
Y 91	5.06E+06									Yb 169	2.77E+06

Table 26: Light Element Half-Lives

Nuclide	Half-Life [s]	Nuclide	Half-Life [s]	Nuclide	Half-Life [s]	Nuclide	Half-Life [s]	Nuclide	Half-Life [s]	Nuclide	Half-Life [s]	Nuclide	Half-Life [s]		
H 3	3.89E+08	Cr 51	2.39E+06	Sr 85	5.60E+06	Rh 103m	3.37E+03	Te 123m	1.03E+07	Pm 148	4.64E+05	Lu 172m	2.22E+02	Ir 192	6.38E+06
Be 10	4.77E+13	Mn 53	1.17E+14	Sr 89	4.37E+06	Rh 106	3.01E+01	Te 125m	4.96E+06	Pm 148m	3.57E+06	Lu 172	5.79E+05	Ir 194	6.94E+04
C 14	1.80E+11	Mn 54	2.70E+07	Sr 90	9.09E+08			Te 127	3.37E+04			Lu 173	4.32E+07		
Na 22	8.21E+07	Fe 55	8.66E+07	Y 88	9.21E+06	Pd 107	2.05E+14	Te 127m	9.42E+06	Sm 145	2.94E+07	Lu 174	1.04E+08	Pt 190	2.05E+19
Al 26	2.26E+13	Fe 59	3.84E+06	Y 89m	1.57E+01	Ag 105	3.57E+06	Te 128	2.78E+26	Sm 146	3.25E+15	Lu 174m	1.23E+07	Pt 193	1.58E+09
Si 32	4.83E+09	Fe 60	4.73E+13	Y 90	2.30E+05	Ag 108	1.43E+02	Te 129	4.18E+03	Sm 147	3.35E+18	Lu 176	1.19E+18	Au 194	1.37E+05
P 32	1.23E+06	Co 56	6.67E+06	Y 91	5.06E+06	Ag 108m	1.38E+10	Te 129m	2.90E+06	Sm 148	2.21E+23	Lu 177m	1.39E+07	Au 195	1.61E+07
P 33	2.19E+06	Co 60	1.66E+08	Zr 88	7.21E+06	Ag 109m	3.96E+01	I 125	5.13E+06	Sm 151	2.84E+09	Lu 177	5.74E+05		
S 35	7.56E+06	Co 60m	6.28E+02	Zr 93	4.83E+13	Ag 110	2.46E+01	I 129	4.95E+14	Eu 148	4.71E+06	Hf 172	5.90E+07	Hg 194	1.40E+10
Cl 36	9.50E+12	Ni 59	2.40E+12	Zr 95	5.53E+06	Ag 110m	2.16E+07	Xe 127	3.14E+06	Eu 149	8.04E+06	Hf 174	6.31E+22	Hg 203	4.03E+06
Ar 37	3.03E+06	Ni 63	3.19E+09	Zr 96	6.31E+26	Cd 109	3.99E+07			Eu 150	1.16E+09	Hf 175	6.05E+06	Hg 206	4.99E+02
Ar 39	8.49E+09	Zn 65	2.11E+07	Nb 91	2.15E+10	Cd 113m	4.45E+08	Cs 134	6.52E+07	Eu 152	4.27E+08	Hf 177m	1.09E+00		
Ar 42	1.04E+09			Nb 91m	5.26E+06	Cd 113	2.54E+23	Cs 135	7.26E+13	Eu 154	2.71E+08	Hf 181	3.66E+06	Tl 202	1.06E+06
K 40	3.94E+16	Ga 68	4.06E+03	Nb 92	1.10E+15	Cd 115m	3.85E+06	Cs 137	9.49E+08	Eu 155	1.50E+08	Hf 182	2.81E+14	Tl 204	1.19E+08
K 42	4.45E+04			Nb 93m	5.09E+08	Cd 116	9.78E+26			Gd 148	2.35E+09	Ta 179	5.74E+07	Tl 206	2.52E+02
Ca 41	3.22E+12	As 73	6.94E+06	Nb 94	6.41E+11	In 113m	5.97E+03	Ba 133	3.32E+08	Gd 150	5.65E+13	Ta 182	9.91E+06	Pb 202	1.66E+12
Ca 45	1.40E+07	Ge 68	2.34E+07	Nb 95	3.02E+06	In 114m	4.28E+06	Ba 137m	1.53E+02	Gd 151	1.07E+07			Pb 204	4.40E+24
Ca 48	7.26E+26	Ge 73m	4.99E-01	Nb 95m	3.12E+05	In 114	7.19E+01	La 137	1.89E+12	Gd 152	3.41E+21	W 180	5.68E+25	Pb 205	5.46E+14
Sc 44	1.43E+04	Mo 93	1.26E+11	Tc 95m	5.27E+06	In 115	1.39E+22	La 138	3.22E+18	Gd 153	2.08E+07	W 181	1.05E+07	Pb 210	7.01E+08
Sc 45m	3.18E-01	Mo 100	2.30E+26	Tc 95	7.20E+04	In 115m	1.61E+04			Tb 157	2.24E+09	W 185	6.49E+06		
Sc 46	7.24E+06	Mo 93	1.26E+11	Tc 97m	7.86E+06	Sn 113	9.94E+06	Ce 139	1.19E+07	Tb 158	5.68E+09	W 186	5.36E+27	Bi 207	9.96E+08
Ti 44	1.89E+09	As 73	6.94E+06	Tc 97	1.33E+14	Sn 119m	2.53E+07	Ce 141	2.81E+06	Tb 160	6.25E+06	W 188	6.03E+06	Bi 208	1.16E+13
V 49	2.85E+07	Se 75	1.03E+07	Tc 98	1.33E+14	Sn 121	9.73E+04	Ce 144	2.46E+07			Re 183	6.05E+06	Bi 209	6.00E+26
V 50	4.42E+24	Se 79	9.31E+12	Tc 99	6.66E+12	Sn 121m	1.39E+09	Pr 144	1.04E+03	Dy 154	9.47E+13	Re 184m	1.46E+07	Bi 210m	9.59E+13
		Kr 81	7.23E+12			Sn 123	1.12E+07	Pr 144m	4.32E+02	Dy 159	1.25E+07	Re 184	3.06E+06	Bi 210	4.33E+05
		Kr 83m	6.59E+03			Sn 126	7.26E+12			Ho 163	1.44E+11	Re 186m	6.31E+12	Po 208	9.15E+07
		Kr 85	3.39E+08	Ru 103	3.39E+06			Nd 144	7.23E+22	Ho 166m	3.79E+10	Re 186	3.21E+05	Po 209	3.22E+09
		Rb 83	7.45E+06	Ru 106	3.21E+07	Sb 124	5.20E+06	Nd 150	2.49E+26			Re 187	1.37E+18	Po 210	1.20E+07
		Rb 84	2.84E+06			Sb 125	8.71E+07			Tm 168	8.04E+06	Re 188	6.12E+04		
		Rb 87	1.52E+18	Rh 101	1.04E+08	Sb 126m	1.15E+03	Pm 143	2.29E+07	Tm 170	1.11E+07	Os 185	8.09E+06		
				Rh 102	1.79E+07	Sb 126	1.07E+06	Pm 144	3.14E+07	Tm 171	6.06E+07	Os 186	6.31E+22		
				Rh 102m	1.18E+08			Pm 145	5.59E+08	Yb 169	2.77E+06	Os 194	1.89E+08		
						Te 121	1.66E+06	Pm 146	1.75E+08						
						Te 121m	1.42E+07	Pm 147	8.28E+07						

APPENDIX E: RADIONUCLIDE INVENTORIES FOR THE REFERENCE FUEL

The results are presented for each burnup (220 MWh/kgU and 290 MWh/kgU) and for the power of 720 kW/bundle. For each burnup and power, the total radionuclide activity (Bq/kgU) and total thermal power (W/kgU), are presented for UO₂ fuel and separately for the Zircaloy cladding.

- 220 MWh/kgU, 720 kW/bundle:
 - The total radionuclide inventories for UO₂ fuel and cladding are presented in Table 27 and Table 28 respectively.
 - The total thermal power for UO₂ fuel and cladding are presented in Table 29.
- 290 MWh/kgU, 720 kW/bundle:
 - The total radionuclide inventories for UO₂ fuel and cladding are presented in Table 30 and Table 31 respectively.
 - The total thermal power for UO₂ fuel and cladding are presented in Table 32.

Table 27: UO2 Fuel - Total Radionuclide Activity (Bq/Initial kg U)

220 MWh/kgU, 720 kW/bundle

Nuclide	0.0 Yrs	5.0 Yrs	10.0 Yrs	15.0 Yrs	20.0 Yrs	30.0 Yrs	40.0 Yrs	50.0 Yrs	70.0 Yrs	100.0 Yrs	200.0 Yrs	300.0 Yrs	500.0 Yrs	1.0E3 Yrs	1.0E4 Yrs	1.0E5 Yrs	1.0E6 Yrs	1.0E7 Yrs	
H 3	1.05E+10	7.94E+09	5.99E+09	4.52E+09	3.41E+09	1.95E+09	1.11E+09	6.31E+08	2.05E+08	3.79E+07	1.36E+05	4.91E+02	6.36E-03	0.00E+00	0.00E+00	0.00E+00	0.00E+00	0.00E+00	
Be 10	1.29E+01	1.29E+01	1.29E+01	1.29E+01	1.29E+01	1.29E+01	1.29E+01	1.29E+01	1.29E+01	1.29E+01	1.29E+01	1.29E+01	1.29E+01	1.28E+01	1.28E+01	1.23E+01	8.12E+00	1.30E-01	
C 14	1.55E+07	1.55E+07	1.55E+07	1.55E+07	1.55E+07	1.55E+07	1.55E+07	1.54E+07	1.54E+07	1.53E+07	1.52E+07	1.50E+07	1.46E+07	1.37E+07	4.60E+06	8.12E+01	0.00E+00	0.00E+00	
Na 22	1.84E+03	4.85E+02	1.28E+02	3.38E+01	8.93E+00	6.22E-01	4.34E-02	3.02E-03	1.47E-05	4.98E-09	0.00E+00	0.00E+00	0.00E+00	0.00E+00	0.00E+00	0.00E+00	0.00E+00	0.00E+00	
Al 26	5.98E-02	5.98E-02	5.98E-02	5.98E-02	5.98E-02	5.98E-02	5.98E-02	5.98E-02	5.98E-02	5.98E-02	5.98E-02	5.98E-02	5.98E-02	5.98E-02	5.93E-02	5.43E-02	2.28E-02	3.79E-06	
Si 32	9.65E+01	9.43E+01	9.22E+01	9.02E+01	8.82E+01	8.42E+01	8.05E+01	7.69E+01	7.03E+01	6.13E+01	3.90E+01	2.48E+01	1.00E+01	1.04E+00	2.03E-18	0.00E+00	0.00E+00	0.00E+00	
P 32	1.66E+10	9.44E+01	9.23E+01	9.02E+01	8.82E+01	8.43E+01	8.05E+01	7.70E+01	7.03E+01	6.14E+01	3.90E+01	2.48E+01	1.00E+01	1.04E+00	0.00E+00	0.00E+00	0.00E+00	0.00E+00	
P 33	1.61E+07	3.24E-15	0.00E+00	0.00E+00	0.00E+00	0.00E+00	0.00E+00	0.00E+00	0.00E+00	0.00E+00	0.00E+00	0.00E+00	0.00E+00	0.00E+00	0.00E+00	0.00E+00	0.00E+00	0.00E+00	
S 35	3.47E+09	1.81E+03	9.44E-04	4.92E-10	0.00E+00	0.00E+00	0.00E+00	0.00E+00	0.00E+00	0.00E+00	0.00E+00	0.00E+00	0.00E+00	0.00E+00	0.00E+00	0.00E+00	0.00E+00	0.00E+00	
Cl 36	4.30E+05	4.30E+05	4.30E+05	4.30E+05	4.30E+05	4.30E+05	4.30E+05	4.30E+05	4.30E+05	4.30E+05	4.30E+05	4.30E+05	4.29E+05	4.29E+05	4.29E+05	4.20E+05	3.41E+05	4.30E+04	4.28E-05
Ar 37	1.31E+09	2.67E-07	0.00E+00	0.00E+00	0.00E+00	0.00E+00	0.00E+00	0.00E+00	0.00E+00	0.00E+00	0.00E+00	0.00E+00	0.00E+00	0.00E+00	0.00E+00	0.00E+00	0.00E+00	0.00E+00	
Ar 39	2.45E+06	2.42E+06	2.39E+06	2.36E+06	2.33E+06	2.27E+06	2.21E+06	2.15E+06	2.05E+06	1.89E+06	1.46E+06	1.13E+06	6.75E+05	1.86E+05	1.58E-05	0.00E+00	0.00E+00	0.00E+00	
Ar 42	9.49E+00	8.54E+00	7.69E+00	6.92E+00	6.23E+00	5.05E+00	4.09E+00	3.31E+00	2.17E+00	1.15E+00	1.40E-01	1.71E-02	2.52E-04	6.71E-09	0.00E+00	0.00E+00	0.00E+00	0.00E+00	
K 40	2.60E+01	2.60E+01	2.60E+01	2.60E+01	2.60E+01	2.60E+01	2.60E+01	2.60E+01	2.60E+01	2.60E+01	2.60E+01	2.60E+01	2.60E+01	2.60E+01	2.60E+01	2.60E+01	2.60E+01	2.60E+01	2.59E+01
K 42	3.61E+09	8.54E+00	7.69E+00	6.92E+00	6.23E+00	5.05E+00	4.09E+00	3.31E+00	2.17E+00	1.15E+00	1.40E-01	1.71E-02	2.52E-04	6.71E-09	0.00E+00	0.00E+00	0.00E+00	0.00E+00	
Ca 41	1.43E+05	1.43E+05	1.43E+05	1.43E+05	1.43E+05	1.43E+05	1.43E+05	1.43E+05	1.43E+05	1.43E+05	1.43E+05	1.43E+05	1.43E+05	1.42E+05	1.34E+05	7.26E+04	1.60E+02	0.00E+00	
Ca 45	9.54E+08	3.97E+05	1.65E+02	6.86E-02	2.85E-05	4.93E-12	0.00E+00	0.00E+00	0.00E+00	0.00E+00	0.00E+00	0.00E+00	0.00E+00	0.00E+00	0.00E+00	0.00E+00	0.00E+00	0.00E+00	
Ca 48	1.32E-09	1.32E-09	1.32E-09	1.32E-09	1.32E-09	1.32E-09	1.32E-09	1.32E-09	1.32E-09	1.32E-09	1.32E-09	1.32E-09	1.32E-09	1.32E-09	1.32E-09	1.32E-09	1.32E-09	1.32E-09	
Sc 44	3.70E+04	1.77E-10	1.67E-10	1.58E-10	1.49E-10	1.33E-10	1.18E-10	1.05E-10	8.36E-11	5.91E-11	1.86E-11	5.86E-12	5.81E-13	0.00E+00	0.00E+00	0.00E+00	0.00E+00	0.00E+00	
Sc 45m	5.02E+07	7.54E+00	3.13E-03	1.30E-06	5.42E-10	0.00E+00	0.00E+00	0.00E+00	0.00E+00	0.00E+00	0.00E+00	0.00E+00	0.00E+00	0.00E+00	0.00E+00	0.00E+00	0.00E+00	0.00E+00	
Sc 46	1.67E+10	4.59E+03	1.26E-03	3.46E-10	0.00E+00	0.00E+00	0.00E+00	0.00E+00	0.00E+00	0.00E+00	0.00E+00	0.00E+00	0.00E+00	0.00E+00	0.00E+00	0.00E+00	0.00E+00	0.00E+00	
Ti 44	1.88E-10	1.77E-10	1.67E-10	1.58E-10	1.49E-10	1.33E-10	1.18E-10	1.05E-10	8.36E-11	5.91E-11	1.86E-11	5.86E-12	5.81E-13	1.80E-15	0.00E+00	0.00E+00	0.00E+00	0.00E+00	
V 49	3.29E+04	7.09E+02	1.53E+01	3.30E-01	7.12E-03	3.32E-06	1.54E-09	7.18E-13	0.00E+00	0.00E+00	0.00E+00	0.00E+00	0.00E+00	0.00E+00	0.00E+00	0.00E+00	0.00E+00	0.00E+00	
V 50	6.24E-09	6.24E-09	6.24E-09	6.24E-09	6.24E-09	6.24E-09	6.24E-09	6.24E-09	6.24E-09	6.24E-09	6.24E-09	6.24E-09	6.24E-09	6.24E-09	6.24E-09	6.24E-09	6.24E-09	6.24E-09	
Cr 51	1.23E+10	1.75E-10	0.00E+00	0.00E+00	0.00E+00	0.00E+00	0.00E+00	0.00E+00	0.00E+00	0.00E+00	0.00E+00	0.00E+00	0.00E+00	0.00E+00	0.00E+00	0.00E+00	0.00E+00	0.00E+00	
Mn 53	9.61E-02	9.61E-02	9.61E-02	9.61E-02	9.61E-02	9.61E-02	9.61E-02	9.61E-02	9.61E-02	9.61E-02	9.61E-02	9.61E-02	9.61E-02	9.61E-02	9.59E-02	9.43E-02	7.97E-02	1.48E-02	

Table 27: UO2 Fuel - Total Radionuclide Activity (Bq/Initial kg U)

220 MWh/kgU, 720 kW/bundle

Nuclide	0.0 Yrs	5.0 Yrs	10.0 Yrs	15.0 Yrs	20.0 Yrs	30.0 Yrs	40.0 Yrs	50.0 Yrs	70.0 Yrs	100.0 Yrs	200.0 Yrs	300.0 Yrs	500.0 Yrs	1.0E3 Yrs	1.0E4 Yrs	1.0E5 Yrs	1.0E6 Yrs	1.0E7 Yrs
Mn 54	1.19E+08	2.06E+06	3.56E+04	6.17E+02	1.07E+01	3.19E-03	9.56E-07	2.86E-10	0.00E+00	0.00E+00	0.00E+00	0.00E+00	0.00E+00	0.00E+00	0.00E+00	0.00E+00	0.00E+00	0.00E+00
Fe 55	1.75E+09	4.96E+08	1.40E+08	3.97E+07	1.12E+07	8.97E+05	7.17E+04	5.73E+03	3.67E+01	1.87E-02	0.00E+00	0.00E+00	0.00E+00	0.00E+00	0.00E+00	0.00E+00	0.00E+00	0.00E+00
Fe 59	3.03E+08	1.34E-04	0.00E+00	0.00E+00	0.00E+00	0.00E+00	0.00E+00	0.00E+00	0.00E+00	0.00E+00	0.00E+00	0.00E+00	0.00E+00	0.00E+00	0.00E+00	0.00E+00	0.00E+00	0.00E+00
Fe 60	5.41E-01	5.41E-01	5.41E-01	5.41E-01	5.41E-01	5.41E-01	5.41E-01	5.41E-01	5.41E-01	5.41E-01	5.41E-01	5.41E-01	5.41E-01	5.41E-01	5.38E-01	5.16E-01	3.41E-01	5.32E-03
Co 56	6.43E+01	4.89E-06	3.72E-13	2.83E-20	0.00E+00	0.00E+00	0.00E+00	0.00E+00	0.00E+00	0.00E+00	0.00E+00	0.00E+00	0.00E+00	0.00E+00	0.00E+00	0.00E+00	0.00E+00	0.00E+00
Co 57	1.60E+06	1.52E+04	1.44E+02	1.36E+00	1.29E-02	1.16E-06	1.04E-10	9.37E-15	0.00E+00	0.00E+00	0.00E+00	0.00E+00	0.00E+00	0.00E+00	0.00E+00	0.00E+00	0.00E+00	0.00E+00
Co 58	3.04E+08	5.33E+00	9.28E-08	0.00E+00	0.00E+00	0.00E+00	0.00E+00	0.00E+00	0.00E+00	0.00E+00	0.00E+00	0.00E+00	0.00E+00	0.00E+00	0.00E+00	0.00E+00	0.00E+00	0.00E+00
Co 60	1.01E+09	5.25E+08	2.72E+08	1.41E+08	7.30E+07	1.96E+07	5.26E+06	1.41E+06	1.02E+05	1.97E+03	5.43E-01	5.40E-01	5.39E-01	5.39E-01	5.37E-01	5.15E-01	3.40E-01	5.31E-03
Co 60m	6.69E+09	5.41E-01	5.41E-01	5.41E-01	5.41E-01	5.41E-01	5.41E-01	5.41E-01	5.41E-01	5.41E-01	5.41E-01	5.41E-01	5.41E-01	5.41E-01	5.38E-01	5.16E-01	3.41E-01	5.32E-03
Ni 59	3.78E+05	3.78E+05	3.78E+05	3.78E+05	3.78E+05	3.78E+05	3.78E+05	3.78E+05	3.78E+05	3.78E+05	3.77E+05	3.77E+05	3.76E+05	3.75E+05	3.45E+05	1.52E+05	4.13E+01	0.00E+00
Ni 63	5.11E+07	4.94E+07	4.78E+07	4.61E+07	4.46E+07	4.16E+07	3.89E+07	3.63E+07	3.17E+07	2.58E+07	1.30E+07	6.55E+06	1.66E+06	5.42E+04	0.00E+00	0.00E+00	0.00E+00	0.00E+00
Zn 65	2.63E+09	1.46E+07	8.15E+04	4.54E+02	2.53E+00	7.86E-05	2.44E-09	0.00E+00	0.00E+00	0.00E+00	0.00E+00	0.00E+00	0.00E+00	0.00E+00	0.00E+00	0.00E+00	0.00E+00	0.00E+00
Ga 68	3.63E+04	1.33E-06	1.24E-08	1.16E-10	1.09E-12	0.00E+00	0.00E+00	0.00E+00	0.00E+00	0.00E+00	0.00E+00	0.00E+00	0.00E+00	0.00E+00	0.00E+00	0.00E+00	0.00E+00	0.00E+00
Ge 68	1.42E-04	1.33E-06	1.24E-08	1.16E-10	1.09E-12	9.49E-17	8.03E-21	0.00E+00	0.00E+00	0.00E+00	0.00E+00	0.00E+00	0.00E+00	0.00E+00	0.00E+00	0.00E+00	0.00E+00	0.00E+00
Ge 73m	2.61E+09	2.83E-04	4.03E-11	0.00E+00	0.00E+00	0.00E+00	0.00E+00	0.00E+00	0.00E+00	0.00E+00	0.00E+00	0.00E+00	0.00E+00	0.00E+00	0.00E+00	0.00E+00	0.00E+00	0.00E+00
As 73	1.99E+03	2.83E-04	4.03E-11	5.73E-18	0.00E+00	0.00E+00	0.00E+00	0.00E+00	0.00E+00	0.00E+00	0.00E+00	0.00E+00	0.00E+00	0.00E+00	0.00E+00	0.00E+00	0.00E+00	0.00E+00
Se 75	7.13E+08	1.83E+04	4.72E-01	1.21E-05	3.12E-10	0.00E+00	0.00E+00	0.00E+00	0.00E+00	0.00E+00	0.00E+00	0.00E+00	0.00E+00	0.00E+00	0.00E+00	0.00E+00	0.00E+00	0.00E+00
Se 79	7.30E+05	7.30E+05	7.30E+05	7.30E+05	7.30E+05	7.30E+05	7.30E+05	7.29E+05	7.29E+05	7.29E+05	7.29E+05	7.29E+05	7.29E+05	7.28E+05	7.13E+05	5.77E+05	6.96E+04	4.55E-05
Kr 81	2.87E+03	2.87E+03	2.87E+03	2.87E+03	2.87E+03	2.87E+03	2.87E+03	2.87E+03	2.87E+03	2.87E+03	2.87E+03	2.87E+03	2.87E+03	2.86E+03	2.79E+03	2.12E+03	1.39E+02	2.05E-10
Kr 83m	3.94E+12	7.47E-02	3.13E-08	7.56E-15	0.00E+00	0.00E+00	0.00E+00	0.00E+00	0.00E+00	0.00E+00	0.00E+00	0.00E+00	0.00E+00	0.00E+00	0.00E+00	0.00E+00	0.00E+00	0.00E+00
Kr 85	1.03E+11	7.43E+10	5.39E+10	3.90E+10	2.83E+10	1.48E+10	7.79E+09	4.09E+09	1.13E+09	1.63E+08	2.59E+05	4.11E+02	1.04E-03	0.00E+00	0.00E+00	0.00E+00	0.00E+00	0.00E+00
Rb 83	2.40E+05	1.01E-01	4.21E-08	1.76E-14	0.00E+00	0.00E+00	0.00E+00	0.00E+00	0.00E+00	0.00E+00	0.00E+00	0.00E+00	0.00E+00	0.00E+00	0.00E+00	0.00E+00	0.00E+00	0.00E+00
Rb 84	4.33E+06	7.66E-11	0.00E+00	0.00E+00	0.00E+00	0.00E+00	0.00E+00	0.00E+00	0.00E+00	0.00E+00	0.00E+00	0.00E+00	0.00E+00	0.00E+00	0.00E+00	0.00E+00	0.00E+00	0.00E+00
Rb 87	2.00E+02	2.00E+02	2.00E+02	2.00E+02	2.00E+02	2.00E+02	2.00E+02	2.00E+02	2.00E+02	2.00E+02	2.00E+02	2.00E+02	2.00E+02	2.00E+02	2.00E+02	2.00E+02	2.00E+02	2.00E+02
Sr 85	1.45E+06	4.82E-03	1.60E-11	0.00E+00	0.00E+00	0.00E+00	0.00E+00	0.00E+00	0.00E+00	0.00E+00	0.00E+00	0.00E+00	0.00E+00	0.00E+00	0.00E+00	0.00E+00	0.00E+00	0.00E+00
Sr 89	3.04E+13	4.00E+02	0.00E+00	0.00E+00	0.00E+00	0.00E+00	0.00E+00	0.00E+00	0.00E+00	0.00E+00	0.00E+00	0.00E+00	0.00E+00	0.00E+00	0.00E+00	0.00E+00	0.00E+00	0.00E+00
Sr 90	7.19E+11	6.37E+11	5.65E+11	5.01E+11	4.44E+11	3.49E+11	2.74E+11	2.16E+11	1.33E+11	6.47E+10	5.82E+09	5.24E+08	4.25E+06	2.51E+01	0.00E+00	0.00E+00	0.00E+00	0.00E+00
Y 88	6.14E+06	4.28E+01	2.99E-04	2.09E-09	1.46E-14	0.00E+00	0.00E+00	0.00E+00	0.00E+00	0.00E+00	0.00E+00	0.00E+00	0.00E+00	0.00E+00	0.00E+00	0.00E+00	0.00E+00	0.00E+00
Y 89m	9.17E+09	3.85E-02	0.00E+00	0.00E+00	0.00E+00	0.00E+00	0.00E+00	0.00E+00	0.00E+00	0.00E+00	0.00E+00	0.00E+00	0.00E+00	0.00E+00	0.00E+00	0.00E+00	0.00E+00	0.00E+00
Y 90	7.98E+11	6.37E+11	5.65E+11	5.01E+11	4.44E+11	3.49E+11	2.74E+11	2.16E+11	1.33E+11	6.47E+10	5.82E+09	5.24E+08	4.25E+06	2.51E+01	0.00E+00	0.00E+00	0.00E+00	0.00E+00

Table 27: UO2 Fuel - Total Radionuclide Activity (Bq/Initial kg U)

220 MWh/kgU, 720 kW/bundle

Nuclide	0.0 Yrs	5.0 Yrs	10.0 Yrs	15.0 Yrs	20.0 Yrs	30.0 Yrs	40.0 Yrs	50.0 Yrs	70.0 Yrs	100.0 Yrs	200.0 Yrs	300.0 Yrs	500.0 Yrs	1.0E3 Yrs	1.0E4 Yrs	1.0E5 Yrs	1.0E6 Yrs	1.0E7 Yrs
Cd 109	3.21E+06	2.06E+05	1.33E+04	8.54E+02	5.49E+01	2.27E-01	9.40E-04	3.89E-06	6.65E-11	0.00E+00	0.00E+00	0.00E+00	0.00E+00	0.00E+00	0.00E+00	0.00E+00	0.00E+00	0.00E+00
Cd 113	4.96E-07	5.38E-07	5.38E-07	5.38E-07	5.38E-07	5.38E-07	5.38E-07	5.38E-07	5.38E-07	5.38E-07	5.38E-07	5.38E-07	5.38E-07	5.38E-07	5.38E-07	5.38E-07	5.38E-07	5.38E-07
Cd 113m	3.48E+06	3.05E+06	2.39E+06	1.87E+06	1.46E+06	8.93E+05	5.46E+05	3.34E+05	1.25E+05	2.86E+04	2.09E+02	1.53E+00	8.23E-05	1.74E-15	0.00E+00	0.00E+00	0.00E+00	0.00E+00
Cd 115m	2.31E+10	1.06E-02	0.00E+00	0.00E+00	0.00E+00	0.00E+00	0.00E+00	0.00E+00	0.00E+00	0.00E+00	0.00E+00	0.00E+00	0.00E+00	0.00E+00	0.00E+00	0.00E+00	0.00E+00	0.00E+00
Cd 116	5.90E-09	5.90E-09	5.90E-09	5.90E-09	5.90E-09	5.90E-09	5.90E-09	5.90E-09	5.90E-09	5.90E-09	5.90E-09	5.90E-09	5.90E-09	5.90E-09	5.90E-09	5.90E-09	5.90E-09	5.90E-09
In 113m	1.28E+07	2.09E+02	3.49E-03	5.82E-08	9.73E-13	0.00E+00	0.00E+00	0.00E+00	0.00E+00	0.00E+00	0.00E+00	0.00E+00	0.00E+00	0.00E+00	0.00E+00	0.00E+00	0.00E+00	0.00E+00
In 114	7.84E+08	3.32E-03	0.00E+00	0.00E+00	0.00E+00	0.00E+00	0.00E+00	0.00E+00	0.00E+00	0.00E+00	0.00E+00	0.00E+00	0.00E+00	0.00E+00	0.00E+00	0.00E+00	0.00E+00	0.00E+00
In 114m	4.37E+08	3.43E-03	0.00E+00	0.00E+00	0.00E+00	0.00E+00	0.00E+00	0.00E+00	0.00E+00	0.00E+00	0.00E+00	0.00E+00	0.00E+00	0.00E+00	0.00E+00	0.00E+00	0.00E+00	0.00E+00
In 115	3.55E-04	3.67E-04	3.67E-04	3.67E-04	3.67E-04	3.67E-04	3.67E-04	3.67E-04	3.67E-04	3.67E-04	3.67E-04	3.67E-04	3.67E-04	3.67E-04	3.67E-04	3.67E-04	3.67E-04	3.67E-04
In 115m	4.30E+11	1.12E-06	0.00E+00	0.00E+00	0.00E+00	0.00E+00	0.00E+00	0.00E+00	0.00E+00	0.00E+00	0.00E+00	0.00E+00	0.00E+00	0.00E+00	0.00E+00	0.00E+00	0.00E+00	0.00E+00
Sn 113	1.25E+07	2.09E+02	3.48E-03	5.82E-08	9.72E-13	0.00E+00	0.00E+00	0.00E+00	0.00E+00	0.00E+00	0.00E+00	0.00E+00	0.00E+00	0.00E+00	0.00E+00	0.00E+00	0.00E+00	0.00E+00
Sn 119m	4.63E+09	6.16E+07	8.18E+05	1.09E+04	1.45E+02	2.55E-02	4.51E-06	7.96E-10	0.00E+00	0.00E+00	0.00E+00	0.00E+00	0.00E+00	0.00E+00	0.00E+00	0.00E+00	0.00E+00	0.00E+00
Sn 121	3.66E+11	1.99E+08	1.84E+08	1.70E+08	1.57E+08	1.34E+08	1.15E+08	9.79E+07	7.14E+07	4.44E+07	9.16E+06	1.89E+06	8.03E+04	2.99E+01	0.00E+00	0.00E+00	0.00E+00	0.00E+00
Sn 121m	2.78E+08	2.57E+08	2.37E+08	2.19E+08	2.03E+08	1.73E+08	1.48E+08	1.26E+08	9.20E+07	5.73E+07	1.18E+07	2.43E+06	1.03E+05	3.85E+01	0.00E+00	0.00E+00	0.00E+00	0.00E+00
Sn 123	4.94E+10	2.74E+06	1.52E+02	8.45E-03	4.69E-07	0.00E+00	0.00E+00	0.00E+00	0.00E+00	0.00E+00	0.00E+00	0.00E+00	0.00E+00	0.00E+00	0.00E+00	0.00E+00	0.00E+00	0.00E+00
Sn 126	2.84E+06	2.84E+06	2.84E+06	2.84E+06	2.84E+06	2.84E+06	2.84E+06	2.84E+06	2.84E+06	2.84E+06	2.84E+06	2.84E+06	2.84E+06	2.83E+06	2.76E+06	2.10E+06	1.39E+05	2.31E-07
Sb 124	4.93E+09	3.63E+00	2.67E-09	0.00E+00	0.00E+00	0.00E+00	0.00E+00	0.00E+00	0.00E+00	0.00E+00	0.00E+00	0.00E+00	0.00E+00	0.00E+00	0.00E+00	0.00E+00	0.00E+00	0.00E+00
Sb 125	1.27E+11	3.73E+10	1.06E+10	3.03E+09	8.61E+08	6.98E+07	5.66E+06	4.58E+05	3.01E+03	1.60E+00	0.00E+00	0.00E+00	0.00E+00	0.00E+00	0.00E+00	0.00E+00	0.00E+00	0.00E+00
Sb 126m	2.21E+10	2.84E+06	2.84E+06	2.84E+06	2.84E+06	2.84E+06	2.84E+06	2.84E+06	2.84E+06	2.84E+06	2.84E+06	2.84E+06	2.84E+06	2.83E+06	2.76E+06	2.10E+06	1.39E+05	2.31E-07
Sb 126	1.88E+10	3.98E+05	3.98E+05	3.98E+05	3.98E+05	3.98E+05	3.98E+05	3.98E+05	3.98E+05	3.98E+05	3.98E+05	3.97E+05	3.97E+05	3.97E+05	3.86E+05	2.94E+05	1.95E+04	3.24E-08
Te 121	1.82E+06	6.06E+01	2.72E-02	1.22E-05	5.46E-09	0.00E+00	0.00E+00	0.00E+00	0.00E+00	0.00E+00	0.00E+00	0.00E+00	0.00E+00	0.00E+00	0.00E+00	0.00E+00	0.00E+00	0.00E+00
Te 121m	1.35E+05	6.04E+01	2.71E-02	1.22E-05	5.45E-09	1.09E-15	0.00E+00	0.00E+00	0.00E+00	0.00E+00	0.00E+00	0.00E+00	0.00E+00	0.00E+00	0.00E+00	0.00E+00	0.00E+00	0.00E+00
Te 123m	2.98E+07	7.28E+02	1.78E-02	4.34E-07	1.06E-11	0.00E+00	0.00E+00	0.00E+00	0.00E+00	0.00E+00	0.00E+00	0.00E+00	0.00E+00	0.00E+00	0.00E+00	0.00E+00	0.00E+00	0.00E+00
Te 125m	1.89E+10	9.14E+09	2.60E+09	7.41E+08	2.11E+08	1.71E+07	1.38E+06	1.12E+05	7.37E+02	3.92E-01	0.00E+00	0.00E+00	0.00E+00	0.00E+00	0.00E+00	0.00E+00	0.00E+00	0.00E+00
Te 127m	1.16E+11	1.28E+06	1.16E+01	1.05E-04	9.46E-10	0.00E+00	0.00E+00	0.00E+00	0.00E+00	0.00E+00	0.00E+00	0.00E+00	0.00E+00	0.00E+00	0.00E+00	0.00E+00	0.00E+00	0.00E+00
Te 127	3.82E+12	1.26E+06	1.14E+01	1.03E-04	9.27E-10	0.00E+00	0.00E+00	0.00E+00	0.00E+00	0.00E+00	0.00E+00	0.00E+00	0.00E+00	0.00E+00	0.00E+00	0.00E+00	0.00E+00	0.00E+00
Te 128	3.40E-07	3.40E-07	3.40E-07	3.40E-07	3.40E-07	3.40E-07	3.40E-07	3.40E-07	3.40E-07	3.40E-07	3.40E-07	3.40E-07	3.40E-07	3.40E-07	3.40E-07	3.40E-07	3.40E-07	3.40E-07
Te 129m	1.13E+12	4.95E-05	0.00E+00	0.00E+00	0.00E+00	0.00E+00	0.00E+00	0.00E+00	0.00E+00	0.00E+00	0.00E+00	0.00E+00	0.00E+00	0.00E+00	0.00E+00	0.00E+00	0.00E+00	0.00E+00
Te 129	1.12E+13	3.12E-05	0.00E+00	0.00E+00	0.00E+00	0.00E+00	0.00E+00	0.00E+00	0.00E+00	0.00E+00	0.00E+00	0.00E+00	0.00E+00	0.00E+00	0.00E+00	0.00E+00	0.00E+00	0.00E+00
I 125	3.87E+07	2.20E-02	1.22E-11	0.00E+00	0.00E+00	0.00E+00	0.00E+00	0.00E+00	0.00E+00	0.00E+00	0.00E+00	0.00E+00	0.00E+00	0.00E+00	0.00E+00	0.00E+00	0.00E+00	0.00E+00
I 129	2.81E+05	2.88E+05	2.88E+05	2.88E+05	2.88E+05	2.88E+05	2.88E+05	2.88E+05	2.88E+05	2.88E+05	2.88E+05	2.88E+05	2.88E+05	2.88E+05	2.88E+05	2.86E+05	2.75E+05	1.85E+05
Xe 127	4.07E+06	3.20E-09	0.00E+00	0.00E+00	0.00E+00	0.00E+00	0.00E+00	0.00E+00	0.00E+00	0.00E+00	0.00E+00	0.00E+00	0.00E+00	0.00E+00	0.00E+00	0.00E+00	0.00E+00	0.00E+00
Cs 134	6.93E+11	1.29E+11	2.42E+10	4.51E+09	8.42E+08	2.94E+07	1.02E+06	3.57E+04	4.33E+01	1.83E-03	0.00E+00	0.00E+00	0.00E+00	0.00E+00	0.00E+00	0.00E+00	0.00E+00	0.00E+00
Cs 135	1.02E+06	1.05E+06	1.05E+06	1.05E+06	1.05E+06	1.05E+06	1.05E+06	1.05E+06	1.05E+06	1.05E+06	1.05E+06	1.05E+06	1.05E+06	1.05E+06	1.04E+06	1.01E+06	7.74E+05	5.13E+04

Table 27: UO2 Fuel - Total Radionuclide Activity (Bq/Initial kg U)

220 MWh/kgU, 720 kW/bundle

Nuclide	0.0 Yrs	5.0 Yrs	10.0 Yrs	15.0 Yrs	20.0 Yrs	30.0 Yrs	40.0 Yrs	50.0 Yrs	70.0 Yrs	100.0 Yrs	200.0 Yrs	300.0 Yrs	500.0 Yrs	1.0E3 Yrs	1.0E4 Yrs	1.0E5 Yrs	1.0E6 Yrs	1.0E7 Yrs
W 188	2.06E+07	2.72E-01	3.59E-09	0.00E+00	0.00E+00	0.00E+00	0.00E+00	0.00E+00	0.00E+00	0.00E+00	0.00E+00	0.00E+00	0.00E+00	0.00E+00	0.00E+00	0.00E+00	0.00E+00	0.00E+00
Re 183	1.73E+01	2.42E-07	3.38E-15	0.00E+00	0.00E+00	0.00E+00	0.00E+00	0.00E+00	0.00E+00	0.00E+00	0.00E+00	0.00E+00	0.00E+00	0.00E+00	0.00E+00	0.00E+00	0.00E+00	0.00E+00
Re 184	1.77E+03	7.41E-02	4.13E-05	2.31E-08	1.29E-11	0.00E+00	0.00E+00	0.00E+00	0.00E+00	0.00E+00	0.00E+00	0.00E+00	0.00E+00	0.00E+00	0.00E+00	0.00E+00	0.00E+00	0.00E+00
Re 184m	1.41E+02	7.86E-02	4.39E-05	2.45E-08	1.37E-11	4.26E-18	0.00E+00	0.00E+00	0.00E+00	0.00E+00	0.00E+00	0.00E+00	0.00E+00	0.00E+00	0.00E+00	0.00E+00	0.00E+00	0.00E+00
Re 186m	2.29E+00	2.29E+00	2.29E+00	2.29E+00	2.29E+00	2.29E+00	2.29E+00	2.29E+00	2.29E+00	2.29E+00	2.29E+00	2.29E+00	2.29E+00	2.29E+00	2.22E+00	1.62E+00	7.17E-02	2.03E-15
Re 186	7.30E+08	2.29E+00	2.29E+00	2.29E+00	2.29E+00	2.29E+00	2.29E+00	2.29E+00	2.29E+00	2.29E+00	2.29E+00	2.29E+00	2.29E+00	2.29E+00	2.22E+00	1.62E+00	7.17E-02	0.00E+00
Re 187	1.32E-01	1.32E-01	1.32E-01	1.32E-01	1.32E-01	1.32E-01	1.32E-01	1.32E-01	1.32E-01	1.32E-01	1.32E-01	1.32E-01	1.32E-01	1.32E-01	1.32E-01	1.32E-01	1.32E-01	1.32E-01
Re 188	2.70E+09	2.74E-01	3.62E-09	0.00E+00	0.00E+00	0.00E+00	0.00E+00	0.00E+00	0.00E+00	0.00E+00	0.00E+00	0.00E+00	0.00E+00	0.00E+00	0.00E+00	0.00E+00	0.00E+00	0.00E+00
Os 185	1.13E+07	1.51E+01	2.02E-05	2.71E-11	0.00E+00	0.00E+00	0.00E+00	0.00E+00	0.00E+00	0.00E+00	0.00E+00	0.00E+00	0.00E+00	0.00E+00	0.00E+00	0.00E+00	0.00E+00	0.00E+00
Os 186	6.48E-07	6.52E-07	6.52E-07	6.52E-07	6.52E-07	6.52E-07	6.52E-07	6.52E-07	6.52E-07	6.52E-07	6.52E-07	6.52E-07	6.52E-07	6.52E-07	6.52E-07	6.52E-07	6.52E-07	6.52E-07
Os 194	1.79E+04	1.00E+04	5.63E+03	3.16E+03	1.77E+03	5.59E+02	1.76E+02	5.54E+01	5.50E+00	1.72E-01	1.65E-06	1.58E-11	0.00E+00	0.00E+00	0.00E+00	0.00E+00	0.00E+00	0.00E+00
Ir 192	6.00E+08	2.14E+01	7.66E-07	0.00E+00	0.00E+00	0.00E+00	0.00E+00	0.00E+00	0.00E+00	0.00E+00	0.00E+00	0.00E+00	0.00E+00	0.00E+00	0.00E+00	0.00E+00	0.00E+00	0.00E+00
Ir 194	2.89E+09	1.00E+04	5.64E+03	3.16E+03	1.77E+03	5.59E+02	1.76E+02	5.54E+01	5.50E+00	1.72E-01	1.65E-06	1.58E-11	0.00E+00	0.00E+00	0.00E+00	0.00E+00	0.00E+00	0.00E+00
Pt 190	2.31E-06	2.31E-06	2.31E-06	2.31E-06	2.31E-06	2.31E-06	2.31E-06	2.31E-06	2.31E-06	2.31E-06	2.31E-06	2.31E-06	2.31E-06	2.31E-06	2.31E-06	2.31E-06	2.31E-06	2.31E-06
Pt 193	3.47E+05	3.27E+05	3.05E+05	2.85E+05	2.66E+05	2.32E+05	2.02E+05	1.75E+05	1.33E+05	8.77E+04	2.19E+04	5.48E+03	3.42E+02	3.34E-01	0.00E+00	0.00E+00	0.00E+00	0.00E+00
Au 194	2.07E-04	9.37E-06	9.30E-06	9.23E-06	9.16E-06	9.01E-06	8.88E-06	8.74E-06	8.47E-06	8.08E-06	6.91E-06	5.91E-06	4.33E-06	1.98E-06	1.57E-12	0.00E+00	0.00E+00	0.00E+00
Au 195	5.69E+01	6.32E-02	7.02E-05	7.80E-08	8.66E-11	1.07E-16	0.00E+00	0.00E+00	0.00E+00	0.00E+00	0.00E+00	0.00E+00	0.00E+00	0.00E+00	0.00E+00	0.00E+00	0.00E+00	0.00E+00
Hg 194	9.45E-06	9.37E-06	9.30E-06	9.23E-06	9.16E-06	9.01E-06	8.88E-06	8.74E-06	8.47E-06	8.08E-06	6.91E-06	5.91E-06	4.33E-06	1.98E-06	1.57E-12	0.00E+00	0.00E+00	0.00E+00
Hg 203	2.20E+08	3.48E-04	0.00E+00	0.00E+00	0.00E+00	0.00E+00	0.00E+00	0.00E+00	0.00E+00	0.00E+00	0.00E+00	0.00E+00	0.00E+00	0.00E+00	0.00E+00	0.00E+00	0.00E+00	0.00E+00
Hg 206	7.68E-01	1.28E-05	1.10E-05	9.42E-06	8.08E-06	5.98E-06	4.51E-06	3.52E-06	2.56E-06	2.79E-06	1.10E-05	3.36E-05	9.20E-05	3.53E-04	1.41E-02	1.27E-01	2.36E-01	2.32E-01
Tl 202	3.19E+05	1.47E-05	1.47E-05	1.47E-05	1.47E-05	1.47E-05	1.47E-05	1.47E-05	1.46E-05	1.46E-05	1.46E-05	1.46E-05	1.46E-05	1.45E-05	1.28E-05	3.92E-06	2.70E-11	0.00E+00
Tl 204	1.62E+08	6.49E+07	2.60E+07	1.04E+07	4.16E+06	6.65E+05	1.06E+05	1.70E+04	4.36E+02	1.79E+00	1.97E-08	0.00E+00	0.00E+00	0.00E+00	0.00E+00	0.00E+00	0.00E+00	0.00E+00
Tl 206	4.51E+07	9.76E-01	9.76E-01	9.76E-01	9.76E-01	9.75E-01	9.75E-01	9.75E-01	9.75E-01	9.75E-01	9.76E-01	9.77E-01	9.81E-01	1.00E+00	1.97E+00	9.88E+00	1.74E+01	1.65E+01
Tl 207	8.94E+03	1.57E+05	2.83E+05	3.91E+05	4.83E+05	6.28E+05	7.33E+05	8.10E+05	9.06E+05	9.72E+05	1.01E+06	1.01E+06	1.01E+06	9.98E+05	8.53E+05	3.90E+05	3.48E+05	3.44E+05
Tl 208	1.43E+07	1.07E+08	1.17E+08	1.13E+08	1.08E+08	9.80E+07	8.86E+07	8.01E+07	6.55E+07	4.84E+07	1.77E+07	6.48E+06	8.67E+05	6.36E+03	7.02E+02	7.09E+02	7.86E+02	1.45E+03
Tl 209	4.33E+02	6.78E+01	9.93E+01	1.31E+02	1.62E+02	2.25E+02	2.88E+02	3.51E+02	4.76E+02	6.63E+02	1.28E+03	1.90E+03	3.11E+03	6.05E+03	4.24E+04	1.07E+05	1.39E+05	7.10E+03
Tl 210	4.33E-05	1.94E-04	5.62E-04	1.13E-03	1.90E-03	4.05E-03	7.01E-03	1.08E-02	2.08E-02	4.20E-02	1.66E-01	3.72E-01	1.02E+00	3.90E+00	1.56E+02	1.40E+03	2.61E+03	2.57E+03
Pb 202	1.47E-05	1.47E-05	1.47E-05	1.47E-05	1.47E-05	1.47E-05	1.47E-05	1.47E-05	1.46E-05	1.46E-05	1.46E-05	1.46E-05	1.46E-05	1.45E-05	1.28E-05	3.92E-06	2.70E-11	0.00E+00
Pb 204	5.80E-09	8.37E-09	9.40E-09	9.81E-09	9.97E-09	1.01E-08	1.01E-08	1.01E-08	1.01E-08	1.01E-08	1.01E-08	1.01E-08	1.01E-08	1.01E-08	1.01E-08	1.01E-08	1.01E-08	1.01E-08
Pb 205	8.82E-02	8.82E-02	8.82E-02	8.82E-02	8.82E-02	8.82E-02	8.82E-02	8.82E-02	8.82E-02	8.82E-02	8.82E-02	8.82E-02	8.82E-02	8.82E-02	8.82E-02	8.78E-02	8.47E-02	5.91E-02
Pb 209	2.64E+05	3.08E+03	4.51E+03	5.95E+03	7.38E+03	1.02E+04	1.31E+04	1.59E+04	2.16E+04	3.02E+04	5.84E+04	8.64E+04	1.42E+05	2.75E+05	1.93E+06	4.88E+06	6.32E+06	3.23E+05
Pb 210	6.40E+02	6.76E+02	5.79E+02	4.96E+02	4.25E+02	3.15E+02	2.37E+02	1.85E+02	1.35E+02	1.47E+02	5.81E+02	1.77E+03	4.84E+03	1.86E+04	7.45E+05	6.67E+06	1.24E+07	1.22E+07
Pb 211	7.88E+03	1.58E+05	2.84E+05	3.92E+05	4.84E+05	6.30E+05	7.35E+05	8.12E+05	9.08E+05	9.75E+05	1.01E+06	1.01E+06	1.01E+06	1.00E+06	8.56E+05	3.91E+05	3.48E+05	3.45E+05
Pb 212	3.97E+07	2.97E+08	3.25E+08	3.16E+08	3.02E+08	2.73E+08	2.47E+08	2.23E+08	1.82E+08	1.35E+08	4.93E+07	1.80E+07	2.41E+06	1.77E+04	1.95E+03	1.97E+03	2.19E+03	4.04E+03

Table 27: UO₂ Fuel - Total Radionuclide Activity (Bq/Initial kg U)

220 MWh/kgU, 720 kW/bundle

Nuclide	0.0 Yrs	5.0 Yrs	10.0 Yrs	15.0 Yrs	20.0 Yrs	30.0 Yrs	40.0 Yrs	50.0 Yrs	70.0 Yrs	100.0 Yrs	200.0 Yrs	300.0 Yrs	500.0 Yrs	1.0E3 Yrs	1.0E4 Yrs	1.0E5 Yrs	1.0E6 Yrs	1.0E7 Yrs
Pb 214	1.19E-01	9.25E-01	2.68E+00	5.39E+00	9.06E+00	1.93E+01	3.34E+01	5.14E+01	9.90E+01	2.00E+02	7.91E+02	1.77E+03	4.84E+03	1.86E+04	7.45E+05	6.67E+06	1.24E+07	1.22E+07
Bi 207	1.24E+01	1.11E+01	9.97E+00	8.93E+00	8.00E+00	6.42E+00	5.16E+00	4.14E+00	2.67E+00	1.38E+00	1.53E-01	1.70E-02	2.10E-04	3.56E-09	0.00E+00	0.00E+00	0.00E+00	0.00E+00
Bi 208	1.76E+00	1.76E+00	1.76E+00	1.76E+00	1.76E+00	1.76E+00	1.76E+00	1.76E+00	1.76E+00	1.76E+00	1.76E+00	1.76E+00	1.76E+00	1.76E+00	1.73E+00	1.46E+00	2.67E-01	1.16E-08
Bi 209	4.13E-09	4.13E-09	4.13E-09	4.13E-09	4.13E-09	4.13E-09	4.13E-09	4.13E-09	4.13E-09	4.13E-09	4.13E-09	4.13E-09	4.13E-09	4.14E-09	4.53E-09	1.74E-08	2.32E-07	9.14E-07
Bi 210m	9.75E-01	9.75E-01	9.75E-01	9.75E-01	9.75E-01	9.75E-01	9.75E-01	9.75E-01	9.75E-01	9.75E-01	9.75E-01	9.75E-01	9.75E-01	9.75E-01	9.73E-01	9.53E-01	7.76E-01	9.97E-02
Bi 210	1.41E+07	6.77E+02	5.79E+02	4.96E+02	4.25E+02	3.15E+02	2.38E+02	1.85E+02	1.35E+02	1.47E+02	5.81E+02	1.77E+03	4.84E+03	1.86E+04	7.45E+05	6.67E+06	1.24E+07	1.22E+07
Bi 211	8.90E+03	1.58E+05	2.84E+05	3.92E+05	4.84E+05	6.30E+05	7.35E+05	8.12E+05	9.08E+05	9.75E+05	1.01E+06	1.01E+06	1.01E+06	1.00E+06	8.56E+05	3.91E+05	3.48E+05	3.45E+05
Bi 212	3.97E+07	2.97E+08	3.25E+08	3.16E+08	3.02E+08	2.73E+08	2.47E+08	2.23E+08	1.82E+08	1.35E+08	4.93E+07	1.80E+07	2.41E+06	1.77E+04	1.95E+03	1.97E+03	2.19E+03	4.04E+03
Bi 213	1.97E+04	3.08E+03	4.51E+03	5.95E+03	7.38E+03	1.02E+04	1.31E+04	1.59E+04	2.16E+04	3.02E+04	5.84E+04	8.63E+04	1.42E+05	2.75E+05	1.93E+06	4.88E+06	6.32E+06	3.23E+05
Bi 214	1.19E-01	9.25E-01	2.68E+00	5.39E+00	9.06E+00	1.93E+01	3.34E+01	5.14E+01	9.91E+01	2.00E+02	7.91E+02	1.77E+03	4.84E+03	1.86E+04	7.45E+05	6.67E+06	1.24E+07	1.22E+07
Po 208	6.12E-03	1.85E-03	5.59E-04	1.69E-04	5.11E-05	4.68E-06	4.28E-07	3.91E-08	3.27E-10	2.50E-13	0.00E+00	0.00E+00	0.00E+00	0.00E+00	0.00E+00	0.00E+00	0.00E+00	0.00E+00
Po 209	2.53E-01	2.45E-01	2.36E-01	2.28E-01	2.21E-01	2.06E-01	1.93E-01	1.80E-01	1.57E-01	1.28E-01	6.50E-02	3.29E-02	8.46E-03	2.83E-04	0.00E+00	0.00E+00	0.00E+00	0.00E+00
Po 210	9.39E+06	1.73E+03	5.79E+02	4.96E+02	4.25E+02	3.15E+02	2.38E+02	1.85E+02	1.35E+02	1.47E+02	5.81E+02	1.77E+03	4.84E+03	1.86E+04	7.45E+05	6.67E+06	1.24E+07	1.22E+07
Po 211	5.62E+02	4.35E+02	7.84E+02	1.08E+03	1.34E+03	1.74E+03	2.03E+03	2.24E+03	2.51E+03	2.69E+03	2.80E+03	2.80E+03	2.79E+03	2.76E+03	2.36E+03	1.08E+03	9.62E+02	9.53E+02
Po 212	2.54E+07	1.90E+08	2.08E+08	2.02E+08	1.93E+08	1.75E+08	1.58E+08	1.43E+08	1.17E+08	8.64E+07	3.16E+07	1.15E+07	1.54E+06	1.13E+04	1.25E+03	1.26E+03	1.40E+03	2.59E+03
Po 213	1.92E+04	3.02E+03	4.42E+03	5.81E+03	7.21E+03	1.00E+04	1.28E+04	1.56E+04	2.12E+04	2.95E+04	5.71E+04	8.45E+04	1.38E+05	2.69E+05	1.88E+06	4.78E+06	6.19E+06	3.16E+05
Po 214	3.48E+04	9.25E-01	2.68E+00	5.39E+00	9.06E+00	1.93E+01	3.34E+01	5.14E+01	9.90E+01	2.00E+02	7.91E+02	1.77E+03	4.84E+03	1.86E+04	7.45E+05	6.67E+06	1.24E+07	1.22E+07
Po 215	7.85E+03	1.58E+05	2.84E+05	3.92E+05	4.84E+05	6.30E+05	7.35E+05	8.12E+05	9.08E+05	9.75E+05	1.01E+06	1.01E+06	1.01E+06	1.00E+06	8.56E+05	3.91E+05	3.48E+05	3.45E+05
Po 216	3.98E+07	2.97E+08	3.25E+08	3.16E+08	3.02E+08	2.73E+08	2.47E+08	2.23E+08	1.82E+08	1.35E+08	4.93E+07	1.80E+07	2.41E+06	1.77E+04	1.95E+03	1.97E+03	2.19E+03	4.04E+03
Po 218	1.19E-01	9.25E-01	2.68E+00	5.39E+00	9.06E+00	1.93E+01	3.34E+01	5.14E+01	9.91E+01	2.00E+02	7.91E+02	1.77E+03	4.84E+03	1.86E+04	7.45E+05	6.67E+06	1.24E+07	1.22E+07
At 217	1.97E+04	3.08E+03	4.51E+03	5.95E+03	7.38E+03	1.02E+04	1.31E+04	1.59E+04	2.16E+04	3.02E+04	5.84E+04	8.64E+04	1.42E+05	2.75E+05	1.93E+06	4.88E+06	6.32E+06	3.23E+05
At 218	2.37E-05	1.85E-04	5.35E-04	1.08E-03	1.81E-03	3.86E-03	6.68E-03	1.03E-02	1.98E-02	4.00E-02	1.58E-01	3.54E-01	9.69E-01	3.72E+00	1.49E+02	1.33E+03	2.49E+03	2.44E+03
Rn 217	1.38E+00	2.16E-01	3.16E-01	4.16E-01	5.16E-01	7.16E-01	9.16E-01	1.12E+00	1.51E+00	2.11E+00	4.09E+00	6.05E+00	9.91E+00	1.93E+01	1.35E+02	3.42E+02	4.43E+02	2.26E+01
Rn 218	3.48E+04	1.85E-07	5.35E-07	1.08E-06	1.81E-06	3.86E-06	6.68E-06	1.03E-05	1.98E-05	4.00E-05	1.58E-04	3.54E-04	9.69E-04	3.72E-03	1.49E-01	1.33E+00	2.49E+00	2.44E+00
Rn 219	7.85E+03	1.58E+05	2.84E+05	3.92E+05	4.84E+05	6.30E+05	7.35E+05	8.12E+05	9.08E+05	9.75E+05	1.01E+06	1.01E+06	1.01E+06	1.00E+06	8.56E+05	3.91E+05	3.48E+05	3.45E+05
Rn 220	3.98E+07	2.97E+08	3.25E+08	3.16E+08	3.02E+08	2.73E+08	2.47E+08	2.23E+08	1.82E+08	1.35E+08	4.93E+07	1.80E+07	2.41E+06	1.77E+04	1.95E+03	1.97E+03	2.19E+03	4.04E+03
Rn 222	1.19E-01	9.25E-01	2.68E+00	5.39E+00	9.06E+00	1.93E+01	3.34E+01	5.14E+01	9.91E+01	2.00E+02	7.91E+02	1.77E+03	4.84E+03	1.86E+04	7.45E+05	6.67E+06	1.24E+07	1.22E+07
Fr 221	1.97E+04	3.08E+03	4.51E+03	5.95E+03	7.38E+03	1.02E+04	1.31E+04	1.59E+04	2.16E+04	3.02E+04	5.84E+04	8.64E+04	1.42E+05	2.75E+05	1.93E+06	4.88E+06	6.32E+06	3.23E+05
Fr 223	1.25E+02	2.17E+03	3.92E+03	5.41E+03	6.68E+03	8.69E+03	1.01E+04	1.12E+04	1.25E+04	1.35E+04	1.40E+04	1.40E+04	1.39E+04	1.38E+04	1.18E+04	5.40E+03	4.81E+03	4.77E+03
Ra 223	7.85E+03	1.58E+05	2.84E+05	3.92E+05	4.84E+05	6.30E+05	7.35E+05	8.12E+05	9.08E+05	9.75E+05	1.01E+06	1.01E+06	1.01E+06	1.00E+06	8.56E+05	3.91E+05	3.48E+05	3.45E+05
Ra 224	3.98E+07	2.97E+08	3.25E+08	3.16E+08	3.02E+08	2.73E+08	2.47E+08	2.23E+08	1.82E+08	1.35E+08	4.93E+07	1.80E+07	2.41E+06	1.77E+04	1.95E+03	1.97E+03	2.19E+03	4.04E+03
Ra 225	2.49E+04	3.08E+03	4.51E+03	5.95E+03	7.38E+03	1.02E+04	1.31E+04	1.59E+04	2.16E+04	3.02E+04	5.84E+04	8.64E+04	1.42E+05	2.75E+05	1.93E+06	4.88E+06	6.32E+06	3.23E+05
Ra 226	1.27E-01	9.25E-01	2.68E+00	5.39E+00	9.06E+00	1.93E+01	3.34E+01	5.14E+01	9.91E+01	2.00E+02	7.91E+02	1.77E+03	4.84E+03	1.86E+04	7.45E+05	6.67E+06	1.24E+07	1.22E+07
Ra 228	2.05E+02	9.95E+02	1.43E+03	1.66E+03	1.79E+03	1.90E+03	1.94E+03	1.95E+03	1.95E+03	1.95E+03	1.95E+03	1.95E+03	1.95E+03	1.95E+03	1.95E+03	1.97E+03	2.19E+03	4.04E+03
Ac 225	1.97E+04	3.08E+03	4.51E+03	5.95E+03	7.38E+03	1.02E+04	1.31E+04	1.59E+04	2.16E+04	3.02E+04	5.84E+04	8.64E+04	1.42E+05	2.75E+05	1.93E+06	4.88E+06	6.32E+06	3.23E+05

Table 27: UO2 Fuel - Total Radionuclide Activity (Bq/Initial kg U)

220 MWh/kgU, 720 kW/bundle

Nuclide	0.0 Yrs	5.0 Yrs	10.0 Yrs	15.0 Yrs	20.0 Yrs	30.0 Yrs	40.0 Yrs	50.0 Yrs	70.0 Yrs	100.0 Yrs	200.0 Yrs	300.0 Yrs	500.0 Yrs	1.0E3 Yrs	1.0E4 Yrs	1.0E5 Yrs	1.0E6 Yrs	1.0E7 Yrs	
Ac 227	9.06E+03	1.58E+05	2.84E+05	3.92E+05	4.84E+05	6.30E+05	7.35E+05	8.12E+05	9.08E+05	9.75E+05	1.01E+06	1.01E+06	1.01E+06	1.00E+06	8.56E+05	3.91E+05	3.48E+05	3.45E+05	
Ac 228	1.19E+06	9.95E+02	1.43E+03	1.66E+03	1.79E+03	1.90E+03	1.94E+03	1.95E+03	1.95E+03	1.95E+03	1.95E+03	1.95E+03	1.95E+03	1.95E+03	1.95E+03	1.97E+03	2.19E+03	4.04E+03	
Th 227	7.92E+03	1.55E+05	2.80E+05	3.87E+05	4.78E+05	6.21E+05	7.25E+05	8.01E+05	8.96E+05	9.61E+05	9.99E+05	9.99E+05	9.95E+05	9.86E+05	8.44E+05	3.86E+05	3.44E+05	3.41E+05	
Th 228	4.11E+07	2.97E+08	3.25E+08	3.16E+08	3.02E+08	2.73E+08	2.47E+08	2.23E+08	1.82E+08	1.35E+08	4.93E+07	1.80E+07	2.41E+06	1.77E+04	1.95E+03	1.97E+03	2.19E+03	4.04E+03	
Th 229	1.66E+03	3.08E+03	4.51E+03	5.95E+03	7.38E+03	1.02E+04	1.31E+04	1.59E+04	2.16E+04	3.02E+04	5.84E+04	8.64E+04	1.42E+05	2.75E+05	1.93E+06	4.88E+06	6.32E+06	3.23E+05	
Th 230	1.48E+02	5.89E+02	1.03E+03	1.48E+03	1.93E+03	2.83E+03	3.74E+03	4.65E+03	6.50E+03	9.32E+03	1.89E+04	2.88E+04	4.86E+04	9.83E+04	9.57E+05	6.67E+06	1.24E+07	1.22E+07	
Th 231	1.92E+09	1.36E+05	1.36E+05	1.36E+05	1.36E+05	1.36E+05	1.36E+05	1.36E+05	1.36E+05	1.37E+05	1.37E+05	1.38E+05	1.39E+05	1.42E+05	1.89E+05	3.37E+05	3.48E+05	3.45E+05	
Th 232	1.95E+03	1.95E+03	1.95E+03	1.95E+03	1.95E+03	1.95E+03	1.95E+03	1.95E+03	1.95E+03	1.95E+03	1.95E+03	1.95E+03	1.95E+03	1.95E+03	1.95E+03	1.97E+03	2.19E+03	4.04E+03	
Th 234	5.40E+08	1.22E+07	1.22E+07	1.22E+07	1.22E+07	1.22E+07	1.22E+07	1.22E+07	1.22E+07	1.22E+07	1.22E+07	1.22E+07	1.22E+07	1.22E+07	1.22E+07	1.22E+07	1.22E+07	1.22E+07	
Pa 231	1.02E+06	1.02E+06	1.02E+06	1.02E+06	1.02E+06	1.02E+06	1.02E+06	1.02E+06	1.02E+06	1.02E+06	1.01E+06	1.01E+06	1.01E+06	9.99E+05	8.55E+05	3.91E+05	3.48E+05	3.45E+05	
Pa 232	4.76E+10	3.66E-03	3.66E-03	3.66E-03	3.66E-03	3.66E-03	3.66E-03	3.66E-03	3.66E-03	3.66E-03	3.66E-03	3.66E-03	3.66E-03	3.65E-03	3.50E-03	2.33E-03	3.95E-05	0.00E+00	
Pa 233	1.64E+12	9.72E+05	9.90E+05	1.02E+06	1.05E+06	1.13E+06	1.22E+06	1.32E+06	1.52E+06	1.83E+06	2.77E+06	3.57E+06	4.84E+06	6.68E+06	8.16E+06	7.93E+06	5.93E+06	3.23E+05	
Pa 234	2.78E+10	1.96E+04	1.96E+04	1.96E+04	1.96E+04	1.96E+04	1.96E+04	1.96E+04	1.96E+04	1.96E+04	1.96E+04	1.96E+04	1.96E+04	1.96E+04	1.96E+04	1.96E+04	1.96E+04	1.96E+04	
Pa 234m	2.95E+10	1.22E+07	1.22E+07	1.22E+07	1.22E+07	1.22E+07	1.22E+07	1.22E+07	1.22E+07	1.22E+07	1.22E+07	1.22E+07	1.22E+07	1.22E+07	1.22E+07	1.22E+07	1.22E+07	1.22E+07	
U 232	3.56E+08	3.41E+08	3.24E+08	3.08E+08	2.93E+08	2.65E+08	2.40E+08	2.17E+08	1.77E+08	1.31E+08	4.79E+07	1.75E+07	2.34E+06	1.53E+04	2.40E-01	1.59E-01	2.70E-03	5.28E-21	
U 233	2.27E+06	3.03E+06	3.03E+06	3.03E+06	3.03E+06	3.03E+06	3.03E+06	3.03E+06	3.03E+06	3.03E+06	3.03E+06	3.03E+06	3.04E+06	3.04E+06	3.23E+06	4.79E+06	6.32E+06	3.23E+05	
U 234	9.57E+06	9.62E+06	9.67E+06	9.71E+06	9.76E+06	9.85E+06	9.93E+06	1.00E+07	1.01E+07	1.03E+07	1.06E+07	1.08E+07	1.09E+07	1.09E+07	1.09E+07	1.12E+07	1.22E+07	1.22E+07	
U 235	1.36E+05	1.36E+05	1.36E+05	1.36E+05	1.36E+05	1.36E+05	1.36E+05	1.36E+05	1.36E+05	1.37E+05	1.37E+05	1.38E+05	1.39E+05	1.42E+05	1.89E+05	3.37E+05	3.48E+05	3.45E+05	
U 236	1.93E+06	1.93E+06	1.94E+06	1.94E+06	1.94E+06	1.94E+06	1.95E+06	1.95E+06	1.96E+06	1.96E+06	2.00E+06	2.03E+06	2.09E+06	2.23E+06	3.87E+06	4.89E+06	4.76E+06	3.65E+06	
U 237	7.14E+12	2.07E+07	1.62E+07	1.27E+07	9.99E+06	6.15E+06	3.79E+06	2.33E+06	8.84E+05	2.06E+05	1.61E+03	1.35E+01	9.02E-01	8.65E-01	4.15E-01	2.70E-04	0.00E+00	0.00E+00	
U 238	1.22E+07	1.22E+07	1.22E+07	1.22E+07	1.22E+07	1.22E+07	1.22E+07	1.22E+07	1.22E+07	1.22E+07	1.22E+07	1.22E+07	1.22E+07	1.22E+07	1.22E+07	1.22E+07	1.22E+07	1.22E+07	
U 240	1.56E+10	1.35E+00	1.35E+00	1.35E+00	1.35E+00	1.35E+00	1.35E+00	1.35E+00	1.35E+00	1.35E+00	1.35E+00	1.35E+00	1.35E+00	1.35E+00	1.35E+00	1.34E+00	1.33E+00	1.24E+00	
Np 235	4.36E+03	1.78E+02	7.31E+00	2.99E-01	1.23E-02	2.05E-05	3.45E-08	5.78E-11	1.62E-16	0.00E+00	0.00E+00	0.00E+00	0.00E+00	0.00E+00	0.00E+00	0.00E+00	0.00E+00	0.00E+00	
Np 236	1.83E+00	1.83E+00	1.83E+00	1.83E+00	1.83E+00	1.83E+00	1.83E+00	1.83E+00	1.83E+00	1.83E+00	1.83E+00	1.83E+00	1.83E+00	1.83E+00	1.82E+00	1.75E+00	1.16E+00	1.97E-02	3.85E-20
Np 237	9.04E+05	9.72E+05	9.90E+05	1.02E+06	1.05E+06	1.13E+06	1.22E+06	1.32E+06	1.52E+06	1.83E+06	2.77E+06	3.57E+06	4.84E+06	6.68E+06	8.16E+06	7.93E+06	5.93E+06	3.23E+05	
Np 238	1.88E+12	3.04E+04	2.96E+04	2.89E+04	2.82E+04	2.69E+04	2.56E+04	2.43E+04	2.21E+04	1.90E+04	1.16E+04	7.12E+03	2.66E+03	2.28E+02	0.00E+00	0.00E+00	0.00E+00	0.00E+00	
Np 239	1.08E+15	4.23E+07	4.23E+07	4.23E+07	4.23E+07	4.22E+07	4.22E+07	4.22E+07	4.21E+07	4.20E+07	4.16E+07	4.12E+07	4.04E+07	3.86E+07	1.65E+07	3.48E+03	5.17E-03	3.47E-03	
Np 240m	2.32E+12	1.35E+00	1.35E+00	1.35E+00	1.35E+00	1.35E+00	1.35E+00	1.35E+00	1.35E+00	1.35E+00	1.35E+00	1.35E+00	1.35E+00	1.35E+00	1.35E+00	1.34E+00	1.33E+00	1.24E+00	
Np 240	1.33E+12	1.61E-03	1.61E-03	1.61E-03	1.61E-03	1.61E-03	1.61E-03	1.61E-03	1.61E-03	1.61E-03	1.61E-03	1.61E-03	1.61E-03	1.61E-03	1.61E-03	1.61E-03	1.60E-03	1.48E-03	
Pu 236	5.40E+05	1.63E+05	4.86E+04	1.44E+04	4.29E+03	3.80E+02	3.38E+01	3.22E+00	2.70E-01	2.47E-01	2.47E-01	2.47E-01	2.47E-01	2.46E-01	2.36E-01	1.57E-01	2.66E-03	0.00E+00	
Pu 237	2.99E+06	2.68E-06	0.00E+00	0.00E+00	0.00E+00	0.00E+00	0.00E+00	0.00E+00	0.00E+00	0.00E+00	0.00E+00	0.00E+00	0.00E+00	0.00E+00	0.00E+00	0.00E+00	0.00E+00	0.00E+00	
Pu 238	3.12E+09	3.55E+09	3.42E+09	3.28E+09	3.16E+09	2.92E+09	2.70E+09	2.49E+09	2.13E+09	1.68E+09	7.63E+08	3.47E+08	7.20E+07	1.41E+06	6.63E-15	0.00E+00	0.00E+00	0.00E+00	
Pu 239	5.91E+09	6.20E+09	6.20E+09	6.20E+09	6.20E+09	6.19E+09	6.19E+09	6.19E+09	6.19E+09	6.18E+09	6.16E+09	6.15E+09	6.11E+09	6.02E+09	4.66E+09	3.51E+08	7.20E-03	3.47E-03	
Pu 240	1.06E+10	1.06E+10	1.06E+10	1.06E+10	1.06E+10	1.06E+10	1.06E+10	1.05E+10	1.05E+10	1.05E+10	1.04E+10	1.03E+10	1.01E+10	9.54E+09	3.68E+09	2.73E+05	1.33E+00	1.24E+00	
Pu 241	1.07E+12	8.43E+11	6.62E+11	5.19E+11	4.07E+11	2.51E+11	1.54E+11	9.50E+10	3.60E+10	8.40E+09	6.58E+07	5.51E+05	3.68E+04	3.53E+04	1.70E+04	1.10E+01	0.00E+00	0.00E+00	
Pu 242	1.46E+07	1.46E+07	1.46E+07	1.46E+07	1.46E+07	1.46E+07	1.46E+07	1.46E+07	1.46E+07	1.46E+07	1.46E+07	1.46E+07	1.46E+07	1.46E+07	1.46E+07	1.44E+07	1.21E+07	2.29E+06	1.27E-01
Pu 243	2.79E+12	5.40E-03	5.40E-03	5.40E-03	5.40E-03	5.40E-03	5.40E-03	5.40E-03	5.40E-03	5.40E-03	5.40E-03	5.40E-03	5.40E-03	5.40E-03	5.40E-03	5.38E-03	5.17E-03	3.47E-03	

Table 27: UO2 Fuel - Total Radionuclide Activity (Bq/Initial kg U)

220 MWh/kgU, 720 kW/bundle

Nuclide	0.0 Yrs	5.0 Yrs	10.0 Yrs	15.0 Yrs	20.0 Yrs	30.0 Yrs	40.0 Yrs	50.0 Yrs	70.0 Yrs	100.0 Yrs	200.0 Yrs	300.0 Yrs	500.0 Yrs	1.0E3 Yrs	1.0E4 Yrs	1.0E5 Yrs	1.0E6 Yrs	1.0E7 Yrs
Pu 244	1.35E+00	1.35E+00	1.35E+00	1.35E+00	1.35E+00	1.35E+00	1.35E+00	1.35E+00	1.35E+00	1.35E+00	1.35E+00	1.35E+00	1.35E+00	1.35E+00	1.35E+00	1.35E+00	1.34E+00	1.24E+00
Pu 246	3.39E-10	6.03E-10	6.03E-10	6.03E-10	6.03E-10	6.02E-10	6.01E-10	6.01E-10	6.00E-10	5.99E-10	5.94E-10	5.88E-10	5.79E-10	5.55E-10	2.62E-10	1.42E-13	0.00E+00	0.00E+00
Am 241	2.90E+08	7.90E+09	1.38E+10	1.84E+10	2.19E+10	2.67E+10	2.94E+10	3.09E+10	3.18E+10	3.12E+10	2.69E+10	2.29E+10	1.66E+10	7.45E+09	2.10E+04	1.16E+01	0.00E+00	0.00E+00
Am 242	4.38E+11	6.59E+06	6.43E+06	6.27E+06	6.12E+06	5.82E+06	5.54E+06	5.28E+06	4.78E+06	4.13E+06	2.53E+06	1.54E+06	5.78E+05	4.94E+04	0.00E+00	0.00E+00	0.00E+00	0.00E+00
Am 242m	6.78E+06	6.62E+06	6.46E+06	6.30E+06	6.14E+06	5.85E+06	5.57E+06	5.30E+06	4.81E+06	4.15E+06	2.54E+06	1.55E+06	5.80E+05	4.97E+04	3.02E-15	0.00E+00	0.00E+00	0.00E+00
Am 243	4.21E+07	4.23E+07	4.23E+07	4.23E+07	4.23E+07	4.22E+07	4.22E+07	4.22E+07	4.21E+07	4.20E+07	4.16E+07	4.12E+07	4.04E+07	3.86E+07	1.65E+07	3.48E+03	5.17E-03	3.47E-03
Am 244	1.88E+10	5.52E-08	3.75E-08	2.55E-08	1.74E-08	8.03E-09	3.72E-09	1.72E-09	3.68E-10	3.64E-11	1.37E-14	0.00E+00	0.00E+00	0.00E+00	0.00E+00	0.00E+00	0.00E+00	0.00E+00
Am 245	1.18E+08	1.59E-06	3.04E-08	5.81E-10	1.11E-11	1.82E-17	0.00E+00	0.00E+00	0.00E+00	0.00E+00	0.00E+00	0.00E+00	0.00E+00	0.00E+00	0.00E+00	0.00E+00	0.00E+00	0.00E+00
Am 246m	4.59E-02	6.03E-10	6.03E-10	6.03E-10	6.03E-10	6.02E-10	6.01E-10	6.01E-10	6.00E-10	5.99E-10	5.94E-10	5.88E-10	5.79E-10	5.55E-10	2.62E-10	1.42E-13	0.00E+00	0.00E+00
Cm 240	3.53E+01	1.53E-19	0.00E+00	0.00E+00	0.00E+00	0.00E+00	0.00E+00	0.00E+00	0.00E+00	0.00E+00	0.00E+00	0.00E+00	0.00E+00	0.00E+00	0.00E+00	0.00E+00	0.00E+00	0.00E+00
Cm 241	9.25E+03	1.60E-13	0.00E+00	0.00E+00	0.00E+00	0.00E+00	0.00E+00	0.00E+00	0.00E+00	0.00E+00	0.00E+00	0.00E+00	0.00E+00	0.00E+00	0.00E+00	0.00E+00	0.00E+00	0.00E+00
Cm 242	8.70E+10	4.28E+07	5.33E+06	5.19E+06	5.06E+06	4.82E+06	4.59E+06	4.37E+06	3.96E+06	3.41E+06	2.09E+06	1.28E+06	4.78E+05	4.09E+04	2.49E-15	0.00E+00	0.00E+00	0.00E+00
Cm 243	1.19E+07	1.06E+07	9.37E+06	8.32E+06	7.38E+06	5.82E+06	4.59E+06	3.61E+06	2.24E+06	1.10E+06	1.01E+05	9.36E+03	7.99E+01	5.36E-04	0.00E+00	0.00E+00	0.00E+00	0.00E+00
Cm 244	1.55E+09	1.28E+09	1.06E+09	8.71E+08	7.20E+08	4.91E+08	3.35E+08	2.28E+08	1.06E+08	3.37E+07	7.33E+05	1.59E+04	7.55E+00	3.68E-08	0.00E+00	0.00E+00	0.00E+00	0.00E+00
Cm 245	3.82E+04	3.82E+04	3.82E+04	3.82E+04	3.82E+04	3.82E+04	3.81E+04	3.81E+04	3.80E+04	3.79E+04	3.76E+04	3.73E+04	3.67E+04	3.53E+04	1.69E+04	1.10E+01	0.00E+00	0.00E+00
Cm 246	7.47E+03	7.46E+03	7.46E+03	7.45E+03	7.45E+03	7.44E+03	7.43E+03	7.41E+03	7.39E+03	7.36E+03	7.26E+03	7.15E+03	6.94E+03	6.45E+03	1.74E+03	3.53E-03	0.00E+00	0.00E+00
Cm 247	5.40E-03	5.40E-03	5.40E-03	5.40E-03	5.40E-03	5.40E-03	5.40E-03	5.40E-03	5.40E-03	5.40E-03	5.40E-03	5.40E-03	5.40E-03	5.40E-03	5.40E-03	5.38E-03	5.17E-03	3.47E-03
Cm 248	5.89E-03	5.89E-03	5.89E-03	5.89E-03	5.89E-03	5.89E-03	5.89E-03	5.89E-03	5.89E-03	5.89E-03	5.89E-03	5.88E-03	5.88E-03	5.88E-03	5.77E-03	4.83E-03	8.03E-04	1.31E-11
Cm 250	3.34E-09	3.35E-09	3.35E-09	3.35E-09	3.35E-09	3.34E-09	3.34E-09	3.34E-09	3.33E-09	3.32E-09	3.30E-09	3.27E-09	3.22E-09	3.08E-09	1.45E-09	7.91E-13	0.00E+00	0.00E+00
Bk 247	1.11E-11	1.11E-11	1.10E-11	1.10E-11	1.10E-11	1.09E-11	1.09E-11	1.08E-11	1.07E-11	1.05E-11	1.00E-11	9.53E-12	8.62E-12	6.71E-12	7.30E-14	0.00E+00	0.00E+00	0.00E+00
Bk 248	8.11E-08	5.51E-08	3.75E-08	2.55E-08	1.74E-08	8.03E-09	3.72E-09	1.72E-09	3.68E-10	3.64E-11	1.64E-14	7.36E-18	0.00E+00	0.00E+00	0.00E+00	0.00E+00	0.00E+00	0.00E+00
Bk 249	5.70E+00	1.09E-01	2.09E-03	4.01E-05	7.67E-07	2.81E-10	1.03E-13	3.75E-17	0.00E+00	0.00E+00	0.00E+00	0.00E+00	0.00E+00	0.00E+00	0.00E+00	0.00E+00	0.00E+00	0.00E+00
Bk 250	6.60E+01	6.59E-09	3.32E-10	2.69E-10	2.68E-10	2.68E-10	2.67E-10	2.67E-10	2.67E-10	2.66E-10	2.64E-10	2.62E-10	2.57E-10	2.47E-10	1.16E-10	6.20E-14	0.00E+00	0.00E+00
Cf 248	4.35E-07	1.02E-08	2.29E-10	5.13E-12	1.15E-13	5.59E-17	2.82E-20	0.00E+00	0.00E+00	0.00E+00	0.00E+00	0.00E+00	0.00E+00	0.00E+00	0.00E+00	0.00E+00	0.00E+00	0.00E+00
Cf 249	4.65E-04	1.44E-02	1.45E-02	1.43E-02	1.42E-02	1.39E-02	1.37E-02	1.34E-02	1.29E-02	1.21E-02	9.96E-03	8.17E-03	5.51E-03	2.05E-03	3.91E-11	0.00E+00	0.00E+00	0.00E+00
Cf 250	1.39E-01	1.08E-01	8.29E-02	6.36E-02	4.88E-02	2.87E-02	1.69E-02	9.95E-03	3.45E-03	7.03E-04	3.51E-06	1.78E-08	2.58E-10	2.47E-10	1.16E-10	6.34E-14	0.00E+00	0.00E+00
Cf 251	3.81E-04	3.79E-04	3.78E-04	3.76E-04	3.75E-04	3.72E-04	3.69E-04	3.66E-04	3.61E-04	3.52E-04	3.26E-04	3.02E-04	2.59E-04	1.76E-04	1.69E-07	0.00E+00	0.00E+00	0.00E+00
Cf 252	7.71E-02	2.08E-02	5.61E-03	1.51E-03	4.08E-04	2.97E-05	2.16E-06	1.57E-07	8.30E-10	3.19E-13	0.00E+00	0.00E+00	0.00E+00	0.00E+00	0.00E+00	0.00E+00	0.00E+00	0.00E+00
Cf 254	1.63E-04	1.34E-13	0.00E+00	0.00E+00	0.00E+00	0.00E+00	0.00E+00	0.00E+00	0.00E+00	0.00E+00	0.00E+00	0.00E+00	0.00E+00	0.00E+00	0.00E+00	0.00E+00	0.00E+00	0.00E+00
Es 252	2.40E-11	1.64E-12	1.12E-13	7.64E-15	5.22E-16	2.43E-18	1.13E-20	0.00E+00	0.00E+00	0.00E+00	0.00E+00	0.00E+00	0.00E+00	0.00E+00	0.00E+00	0.00E+00	0.00E+00	0.00E+00
Es 254	5.91E-07	6.32E-09	6.40E-11	6.49E-13	6.55E-15	6.40E-19	0.00E+00	0.00E+00	0.00E+00	0.00E+00	0.00E+00	0.00E+00	0.00E+00	0.00E+00	0.00E+00	0.00E+00	0.00E+00	0.00E+00
Es 255	3.92E-06	5.97E-20	0.00E+00	0.00E+00	0.00E+00	0.00E+00	0.00E+00	0.00E+00	0.00E+00	0.00E+00	0.00E+00	0.00E+00	0.00E+00	0.00E+00	0.00E+00	0.00E+00	0.00E+00	0.00E+00
Total⁹	1.59E+15	6.41E+12	3.90E+12	3.21E+12	2.76E+12	2.10E+12	1.62E+12	1.26E+12	7.86E+11	4.05E+11	7.86E+10	4.36E+10	3.33E+10	2.34E+10	8.69E+09	6.98E+08	2.83E+08	1.83E+08

⁹ Note: The total at time zero represents the total activity of those nuclides presented only. The activity from short-lived nuclides is not included in this total.

Table 28: Zircaloy Cladding - Total Radionuclide Activity (Bq/Initial kg Zr)

220 MWh/kgU, 720 kW/bundle

Nuclide	0.0 Yrs	5.0 Yrs	10.0 Yrs	15.0 Yrs	20.0 Yrs	30.0 Yrs	40.0 Yrs	50.0 Yrs	70.0 Yrs	100.0 Yrs	200.0 Yrs	300.0 Yrs	500.0 Yrs	1.0E3 Yrs	1.0E4 Yrs	1.0E5 Yrs	1.0E6 Yrs	1.0E7 Yrs	
Y 89m	3.34E+10	8.09E-06	0.00E+00	0.00E+00	0.00E+00	0.00E+00	0.00E+00	0.00E+00	0.00E+00	0.00E+00	0.00E+00	0.00E+00	0.00E+00	0.00E+00	0.00E+00	0.00E+00	0.00E+00	0.00E+00	0.00E+00
Y 90	5.62E+10	2.94E+07	2.61E+07	2.31E+07	2.05E+07	1.61E+07	1.27E+07	9.96E+06	6.16E+06	2.99E+06	2.69E+05	2.42E+04	1.96E+02	1.16E-03	0.00E+00	0.00E+00	0.00E+00	0.00E+00	0.00E+00
Y 91	8.26E+09	3.32E+00	1.33E-09	0.00E+00	0.00E+00	0.00E+00	0.00E+00	0.00E+00	0.00E+00	0.00E+00	0.00E+00	0.00E+00	0.00E+00	0.00E+00	0.00E+00	0.00E+00	0.00E+00	0.00E+00	0.00E+00
Zr 88	5.60E+02	1.43E-04	3.66E-11	9.36E-18	0.00E+00	0.00E+00	0.00E+00	0.00E+00	0.00E+00	0.00E+00	0.00E+00	0.00E+00	0.00E+00	0.00E+00	0.00E+00	0.00E+00	0.00E+00	0.00E+00	0.00E+00
Zr 93	1.07E+07	1.07E+07	1.07E+07	1.07E+07	1.07E+07	1.07E+07	1.07E+07	1.07E+07	1.07E+07	1.07E+07	1.07E+07	1.07E+07	1.07E+07	1.07E+07	1.07E+07	1.06E+07	1.02E+07	6.79E+06	1.15E+05
Zr 95	9.95E+12	2.58E+04	6.68E-05	0.00E+00	0.00E+00	0.00E+00	0.00E+00	0.00E+00	0.00E+00	0.00E+00	0.00E+00	0.00E+00	0.00E+00	0.00E+00	0.00E+00	0.00E+00	0.00E+00	0.00E+00	0.00E+00
Zr 96	1.99E-04	1.99E-04	1.99E-04	1.99E-04	1.99E-04	1.99E-04	1.99E-04	1.99E-04	1.99E-04	1.99E-04	1.99E-04	1.99E-04	1.99E-04	1.99E-04	1.99E-04	1.99E-04	1.99E-04	1.99E-04	1.99E-04
Nb 91	9.90E+02	1.05E+03	1.04E+03	1.04E+03	1.03E+03	1.02E+03	1.01E+03	1.00E+03	9.81E+02	9.52E+02	8.59E+02	7.76E+02	6.33E+02	3.80E+02	3.94E-02	0.00E+00	0.00E+00	0.00E+00	0.00E+00
Nb 91m	2.71E+05	2.51E-04	2.32E-13	0.00E+00	0.00E+00	0.00E+00	0.00E+00	0.00E+00	0.00E+00	0.00E+00	0.00E+00	0.00E+00	0.00E+00	0.00E+00	0.00E+00	0.00E+00	0.00E+00	0.00E+00	0.00E+00
Nb 92	8.70E-01	8.70E-01	8.70E-01	8.70E-01	8.70E-01	8.70E-01	8.70E-01	8.70E-01	8.70E-01	8.70E-01	8.70E-01	8.70E-01	8.70E-01	8.70E-01	8.70E-01	8.70E-01	8.69E-01	8.53E-01	7.13E-01
Nb 93m	3.17E+07	2.76E+07	2.43E+07	2.16E+07	1.95E+07	1.63E+07	1.43E+07	1.30E+07	1.15E+07	1.08E+07	1.05E+07	1.05E+07	1.05E+07	1.05E+07	1.05E+07	1.04E+07	9.96E+06	6.62E+06	1.12E+05
Nb 94	3.28E+06	3.28E+06	3.28E+06	3.28E+06	3.27E+06	3.27E+06	3.27E+06	3.27E+06	3.27E+06	3.27E+06	3.25E+06	3.24E+06	3.22E+06	3.17E+06	2.33E+06	1.08E+05	4.84E-09	0.00E+00	0.00E+00
Nb 95	8.94E+12	5.69E+04	1.47E-04	0.00E+00	0.00E+00	0.00E+00	0.00E+00	0.00E+00	0.00E+00	0.00E+00	0.00E+00	0.00E+00	0.00E+00	0.00E+00	0.00E+00	0.00E+00	0.00E+00	0.00E+00	0.00E+00
Nb 95m	1.07E+11	2.95E+02	7.65E-07	0.00E+00	0.00E+00	0.00E+00	0.00E+00	0.00E+00	0.00E+00	0.00E+00	0.00E+00	0.00E+00	0.00E+00	0.00E+00	0.00E+00	0.00E+00	0.00E+00	0.00E+00	0.00E+00
Mo 93	6.80E+04	6.80E+04	6.79E+04	6.78E+04	6.78E+04	6.77E+04	6.76E+04	6.74E+04	6.72E+04	6.69E+04	6.57E+04	6.46E+04	6.24E+04	5.72E+04	1.20E+04	2.02E-03	0.00E+00	0.00E+00	0.00E+00
Mo 100	8.01E-08	8.01E-08	8.01E-08	8.01E-08	8.01E-08	8.01E-08	8.01E-08	8.01E-08	8.01E-08	8.01E-08	8.01E-08	8.01E-08	8.01E-08	8.01E-08	8.01E-08	8.01E-08	8.01E-08	8.01E-08	8.01E-08
Tc 95m	7.39E+00	7.21E-09	6.98E-18	0.00E+00	0.00E+00	0.00E+00	0.00E+00	0.00E+00	0.00E+00	0.00E+00	0.00E+00	0.00E+00	0.00E+00	0.00E+00	0.00E+00	0.00E+00	0.00E+00	0.00E+00	0.00E+00
Tc 95	5.35E+01	2.83E-10	0.00E+00	0.00E+00	0.00E+00	0.00E+00	0.00E+00	0.00E+00	0.00E+00	0.00E+00	0.00E+00	0.00E+00	0.00E+00	0.00E+00	0.00E+00	0.00E+00	0.00E+00	0.00E+00	0.00E+00
Tc 97m	3.93E+02	3.71E-04	3.38E-10	2.95E-16	0.00E+00	0.00E+00	0.00E+00	0.00E+00	0.00E+00	0.00E+00	0.00E+00	0.00E+00	0.00E+00	0.00E+00	0.00E+00	0.00E+00	0.00E+00	0.00E+00	0.00E+00
Tc 97	1.35E-01	1.37E-01	1.37E-01	1.37E-01	1.37E-01	1.37E-01	1.37E-01	1.37E-01	1.37E-01	1.37E-01	1.37E-01	1.37E-01	1.37E-01	1.37E-01	1.37E-01	1.37E-01	1.35E-01	1.17E-01	2.65E-02
Tc 98	5.32E-03	5.32E-03	5.32E-03	5.32E-03	5.32E-03	5.32E-03	5.32E-03	5.32E-03	5.32E-03	5.32E-03	5.32E-03	5.32E-03	5.32E-03	5.32E-03	5.32E-03	5.31E-03	5.23E-03	4.51E-03	1.02E-03
Tc 99	1.69E+04	1.72E+04	1.72E+04	1.72E+04	1.72E+04	1.72E+04	1.72E+04	1.72E+04	1.72E+04	1.72E+04	1.72E+04	1.72E+04	1.72E+04	1.72E+04	1.71E+04	1.66E+04	1.24E+04	6.45E+02	9.42E-11
Ru 103	2.90E+09	2.84E-05	0.00E+00	0.00E+00	0.00E+00	0.00E+00	0.00E+00	0.00E+00	0.00E+00	0.00E+00	0.00E+00	0.00E+00	0.00E+00	0.00E+00	0.00E+00	0.00E+00	0.00E+00	0.00E+00	0.00E+00
Ru 106	4.72E+08	1.57E+07	5.20E+05	1.73E+04	5.73E+02	6.32E-01	6.97E-04	7.68E-07	9.34E-13	0.00E+00	0.00E+00	0.00E+00	0.00E+00	0.00E+00	0.00E+00	0.00E+00	0.00E+00	0.00E+00	0.00E+00
Rh 101	1.45E+02	5.21E+01	1.82E+01	6.38E+00	2.23E+00	2.73E-01	3.34E-02	4.09E-03	6.13E-05	1.12E-07	8.26E-17	0.00E+00	0.00E+00	0.00E+00	0.00E+00	0.00E+00	0.00E+00	0.00E+00	0.00E+00
Rh 102	4.84E+04	1.13E+02	2.31E+00	8.20E-01	3.24E-01	5.09E-02	7.98E-03	1.25E-03	3.08E-05	1.19E-07	1.31E-17	0.00E+00	0.00E+00	0.00E+00	0.00E+00	0.00E+00	0.00E+00	0.00E+00	0.00E+00
Rh 102m	4.80E+03	1.90E+03	7.53E+02	2.98E+02	1.18E+02	1.85E+01	2.91E+00	4.56E-01	1.12E-02	4.33E-05	3.90E-13	0.00E+00	0.00E+00	0.00E+00	0.00E+00	0.00E+00	0.00E+00	0.00E+00	0.00E+00
Rh 103m	2.98E+09	2.81E-05	0.00E+00	0.00E+00	0.00E+00	0.00E+00	0.00E+00	0.00E+00	0.00E+00	0.00E+00	0.00E+00	0.00E+00	0.00E+00	0.00E+00	0.00E+00	0.00E+00	0.00E+00	0.00E+00	0.00E+00
Rh 106	9.72E+08	1.57E+07	5.20E+05	1.73E+04	5.73E+02	6.32E-01	6.97E-04	7.68E-07	9.34E-13	0.00E+00	0.00E+00	0.00E+00	0.00E+00	0.00E+00	0.00E+00	0.00E+00	0.00E+00	0.00E+00	0.00E+00
Pd 107	1.31E+02	1.31E+02	1.31E+02	1.31E+02	1.31E+02	1.31E+02	1.31E+02	1.31E+02	1.31E+02	1.31E+02	1.31E+02	1.31E+02	1.31E+02	1.31E+02	1.31E+02	1.31E+02	1.29E+02	1.17E+02	4.50E+01
Ag 105	8.53E+01	4.13E-12	0.00E+00	0.00E+00	0.00E+00	0.00E+00	0.00E+00	0.00E+00	0.00E+00	0.00E+00	0.00E+00	0.00E+00	0.00E+00	0.00E+00	0.00E+00	0.00E+00	0.00E+00	0.00E+00	0.00E+00
Ag 108	5.03E+10	4.14E+04	4.11E+04	4.08E+04	4.05E+04	3.98E+04	3.92E+04	3.86E+04	3.74E+04	3.56E+04	3.04E+04	2.60E+04	1.89E+04	8.58E+03	5.59E-03	0.00E+00	0.00E+00	0.00E+00	0.00E+00
Ag 108m	4.80E+05	4.76E+05	4.72E+05	4.69E+05	4.65E+05	4.58E+05	4.51E+05	4.43E+05	4.30E+05	4.10E+05	3.50E+05	2.99E+05	2.18E+05	9.86E+04	6.42E-02	0.00E+00	0.00E+00	0.00E+00	0.00E+00

Table 28: Zircaloy Cladding - Total Radionuclide Activity (Bq/Initial kg Zr)

220 MWh/kgU, 720 kW/bundle

Nuclide	0.0 Yrs	5.0 Yrs	10.0 Yrs	15.0 Yrs	20.0 Yrs	30.0 Yrs	40.0 Yrs	50.0 Yrs	70.0 Yrs	100.0 Yrs	200.0 Yrs	300.0 Yrs	500.0 Yrs	1.0E3 Yrs	1.0E4 Yrs	1.0E5 Yrs	1.0E6 Yrs	1.0E7 Yrs	
Ag 109m	2.03E+10	2.08E+06	1.34E+05	8.60E+03	5.53E+02	2.29E+00	9.47E-03	3.92E-05	6.71E-10	0.00E+00	0.00E+00	0.00E+00	0.00E+00	0.00E+00	0.00E+00	0.00E+00	0.00E+00	0.00E+00	0.00E+00
Ag 110	1.27E+11	2.62E+05	1.65E+03	1.04E+01	6.51E-02	2.58E-06	1.02E-10	0.00E+00	0.00E+00	0.00E+00	0.00E+00	0.00E+00	0.00E+00	0.00E+00	0.00E+00	0.00E+00	0.00E+00	0.00E+00	0.00E+00
Ag 110m	3.06E+09	1.92E+07	1.21E+05	7.61E+02	4.79E+00	1.90E-04	7.50E-09	0.00E+00	0.00E+00	0.00E+00	0.00E+00	0.00E+00	0.00E+00	0.00E+00	0.00E+00	0.00E+00	0.00E+00	0.00E+00	0.00E+00
Cd 109	3.23E+07	2.08E+06	1.34E+05	8.60E+03	5.53E+02	2.29E+00	9.47E-03	3.92E-05	6.71E-10	0.00E+00	0.00E+00	0.00E+00	0.00E+00	0.00E+00	0.00E+00	0.00E+00	0.00E+00	0.00E+00	0.00E+00
Cd 113m	1.68E+04	1.32E+04	1.03E+04	8.05E+03	6.30E+03	3.86E+03	2.35E+03	1.44E+03	5.39E+02	1.23E+02	9.03E-01	6.62E-03	3.55E-07	7.49E-18	0.00E+00	0.00E+00	0.00E+00	0.00E+00	0.00E+00
Cd 113	2.11E-10	2.13E-10	2.13E-10	2.13E-10	2.13E-10	2.13E-10	2.13E-10	2.13E-10	2.13E-10	2.13E-10	2.13E-10	2.13E-10	2.13E-10	2.13E-10	2.13E-10	2.13E-10	2.13E-10	2.13E-10	2.13E-10
Cd 115m	3.09E+07	1.42E-05	0.00E+00	0.00E+00	0.00E+00	0.00E+00	0.00E+00	0.00E+00	0.00E+00	0.00E+00	0.00E+00	0.00E+00	0.00E+00	0.00E+00	0.00E+00	0.00E+00	0.00E+00	0.00E+00	0.00E+00
Cd 116	2.30E-10	2.30E-10	2.30E-10	2.30E-10	2.30E-10	2.30E-10	2.30E-10	2.30E-10	2.30E-10	2.30E-10	2.30E-10	2.30E-10	2.30E-10	2.30E-10	2.30E-10	2.30E-10	2.30E-10	2.30E-10	2.30E-10
In 113m	1.93E+11	3.22E+06	5.38E+01	8.99E-04	1.50E-08	0.00E+00	0.00E+00	0.00E+00	0.00E+00	0.00E+00	0.00E+00	0.00E+00	0.00E+00	0.00E+00	0.00E+00	0.00E+00	0.00E+00	0.00E+00	0.00E+00
In 114m	3.14E+09	2.47E-02	0.00E+00	0.00E+00	0.00E+00	0.00E+00	0.00E+00	0.00E+00	0.00E+00	0.00E+00	0.00E+00	0.00E+00	0.00E+00	0.00E+00	0.00E+00	0.00E+00	0.00E+00	0.00E+00	0.00E+00
In 114	6.96E+09	2.39E-02	0.00E+00	0.00E+00	0.00E+00	0.00E+00	0.00E+00	0.00E+00	0.00E+00	0.00E+00	0.00E+00	0.00E+00	0.00E+00	0.00E+00	0.00E+00	0.00E+00	0.00E+00	0.00E+00	0.00E+00
In 115	8.87E-06	8.88E-06	8.88E-06	8.88E-06	8.88E-06	8.88E-06	8.88E-06	8.88E-06	8.88E-06	8.88E-06	8.88E-06	8.88E-06	8.88E-06	8.88E-06	8.88E-06	8.88E-06	8.88E-06	8.88E-06	8.88E-06
In 115m	4.38E+08	1.51E-09	0.00E+00	0.00E+00	0.00E+00	0.00E+00	0.00E+00	0.00E+00	0.00E+00	0.00E+00	0.00E+00	0.00E+00	0.00E+00	0.00E+00	0.00E+00	0.00E+00	0.00E+00	0.00E+00	0.00E+00
Sn 113	1.93E+11	3.22E+06	5.38E+01	8.99E-04	1.50E-08	0.00E+00	0.00E+00	0.00E+00	0.00E+00	0.00E+00	0.00E+00	0.00E+00	0.00E+00	0.00E+00	0.00E+00	0.00E+00	0.00E+00	0.00E+00	0.00E+00
Sn 119m	2.60E+11	3.46E+09	4.59E+07	6.11E+05	8.11E+03	1.43E+00	2.53E-04	4.47E-08	0.00E+00	0.00E+00	0.00E+00	0.00E+00	0.00E+00	0.00E+00	0.00E+00	0.00E+00	0.00E+00	0.00E+00	0.00E+00
Sn 121	7.84E+11	6.14E+07	5.68E+07	5.25E+07	4.85E+07	4.14E+07	3.53E+07	3.02E+07	2.20E+07	1.37E+07	2.83E+06	5.83E+05	2.48E+04	9.22E+00	0.00E+00	0.00E+00	0.00E+00	0.00E+00	0.00E+00
Sn 121m	8.57E+07	7.92E+07	7.32E+07	6.76E+07	6.25E+07	5.33E+07	4.55E+07	3.89E+07	2.84E+07	1.77E+07	3.64E+06	7.51E+05	3.19E+04	1.19E+01	0.00E+00	0.00E+00	0.00E+00	0.00E+00	0.00E+00
Sn 123	1.09E+09	6.06E+04	3.36E+00	1.87E-04	1.04E-08	0.00E+00	0.00E+00	0.00E+00	0.00E+00	0.00E+00	0.00E+00	0.00E+00	0.00E+00	0.00E+00	0.00E+00	0.00E+00	0.00E+00	0.00E+00	0.00E+00
Sn 126	1.33E+02	1.33E+02	1.33E+02	1.33E+02	1.33E+02	1.33E+02	1.33E+02	1.33E+02	1.33E+02	1.33E+02	1.33E+02	1.33E+02	1.33E+02	1.33E+02	1.33E+02	1.29E+02	9.86E+01	6.54E+00	1.08E-11
Sb 124	4.40E+09	3.24E+00	2.38E-09	0.00E+00	0.00E+00	0.00E+00	0.00E+00	0.00E+00	0.00E+00	0.00E+00	0.00E+00	0.00E+00	0.00E+00	0.00E+00	0.00E+00	0.00E+00	0.00E+00	0.00E+00	0.00E+00
Sb 125	5.18E+10	1.48E+10	4.21E+09	1.20E+09	3.41E+08	2.77E+07	2.24E+06	1.82E+05	1.19E+03	6.34E-01	0.00E+00	0.00E+00	0.00E+00	0.00E+00	0.00E+00	0.00E+00	0.00E+00	0.00E+00	0.00E+00
Sb 126m	4.02E+08	1.33E+02	1.33E+02	1.33E+02	1.33E+02	1.33E+02	1.33E+02	1.33E+02	1.33E+02	1.33E+02	1.33E+02	1.33E+02	1.33E+02	1.33E+02	1.29E+02	9.86E+01	6.54E+00	1.08E-11	0.00E+00
Sb 126	1.70E+09	1.87E+01	1.87E+01	1.87E+01	1.87E+01	1.87E+01	1.87E+01	1.87E+01	1.87E+01	1.87E+01	1.86E+01	1.86E+01	1.86E+01	1.86E+01	1.81E+01	1.38E+01	9.16E-01	1.52E-12	0.00E+00
Te 121	1.74E+07	5.77E+02	2.59E-01	1.16E-04	5.20E-08	0.00E+00	0.00E+00	0.00E+00	0.00E+00	0.00E+00	0.00E+00	0.00E+00	0.00E+00	0.00E+00	0.00E+00	0.00E+00	0.00E+00	0.00E+00	0.00E+00
Te 121m	1.28E+06	5.75E+02	2.58E-01	1.16E-04	5.18E-08	1.04E-14	0.00E+00	0.00E+00	0.00E+00	0.00E+00	0.00E+00	0.00E+00	0.00E+00	0.00E+00	0.00E+00	0.00E+00	0.00E+00	0.00E+00	0.00E+00
Te 123m	2.09E+08	5.11E+03	1.25E-01	3.05E-06	7.44E-11	0.00E+00	0.00E+00	0.00E+00	0.00E+00	0.00E+00	0.00E+00	0.00E+00	0.00E+00	0.00E+00	0.00E+00	0.00E+00	0.00E+00	0.00E+00	0.00E+00
Te 125m	8.32E+09	3.62E+09	1.03E+09	2.94E+08	8.36E+07	6.77E+06	5.49E+05	4.45E+04	2.92E+02	1.55E-01	0.00E+00	0.00E+00	0.00E+00	0.00E+00	0.00E+00	0.00E+00	0.00E+00	0.00E+00	0.00E+00
Te 127	1.06E+09	2.53E+02	2.29E-03	2.07E-08	1.87E-13	0.00E+00	0.00E+00	0.00E+00	0.00E+00	0.00E+00	0.00E+00	0.00E+00	0.00E+00	0.00E+00	0.00E+00	0.00E+00	0.00E+00	0.00E+00	0.00E+00
Te 127m	2.74E+07	2.59E+02	2.34E-03	2.11E-08	1.91E-13	0.00E+00	0.00E+00	0.00E+00	0.00E+00	0.00E+00	0.00E+00	0.00E+00	0.00E+00	0.00E+00	0.00E+00	0.00E+00	0.00E+00	0.00E+00	0.00E+00
Te 128	3.74E-08	3.74E-08	3.74E-08	3.74E-08	3.74E-08	3.74E-08	3.74E-08	3.74E-08	3.74E-08	3.74E-08	3.74E-08	3.74E-08	3.74E-08	3.74E-08	3.74E-08	3.74E-08	3.74E-08	3.74E-08	3.74E-08
Te 129	1.02E+09	2.08E-09	0.00E+00	0.00E+00	0.00E+00	0.00E+00	0.00E+00	0.00E+00	0.00E+00	0.00E+00	0.00E+00	0.00E+00	0.00E+00	0.00E+00	0.00E+00	0.00E+00	0.00E+00	0.00E+00	0.00E+00
Te 129m	7.57E+07	3.30E-09	0.00E+00	0.00E+00	0.00E+00	0.00E+00	0.00E+00	0.00E+00	0.00E+00	0.00E+00	0.00E+00	0.00E+00	0.00E+00	0.00E+00	0.00E+00	0.00E+00	0.00E+00	0.00E+00	0.00E+00
I 125	3.48E+06	1.99E-03	1.12E-12	0.00E+00	0.00E+00	0.00E+00	0.00E+00	0.00E+00	0.00E+00	0.00E+00	0.00E+00	0.00E+00	0.00E+00	0.00E+00	0.00E+00	0.00E+00	0.00E+00	0.00E+00	0.00E+00
I 129	2.68E+01	2.72E+01	2.72E+01	2.72E+01	2.72E+01	2.72E+01	2.72E+01	2.72E+01	2.72E+01	2.72E+01	2.72E+01	2.72E+01	2.72E+01	2.72E+01	2.72E+01	2.72E+01	2.71E+01	2.61E+01	1.75E+01

Table 28: Zircaloy Cladding - Total Radionuclide Activity (Bq/Initial kg Zr)

220 MWh/kgU, 720 kW/bundle

Nuclide	0.0 Yrs	5.0 Yrs	10.0 Yrs	15.0 Yrs	20.0 Yrs	30.0 Yrs	40.0 Yrs	50.0 Yrs	70.0 Yrs	100.0 Yrs	200.0 Yrs	300.0 Yrs	500.0 Yrs	1.0E3 Yrs	1.0E4 Yrs	1.0E5 Yrs	1.0E6 Yrs	1.0E7 Yrs
Xe 127	3.24E+05	2.57E-10	0.00E+00	0.00E+00	0.00E+00	0.00E+00	0.00E+00	0.00E+00	0.00E+00	0.00E+00	0.00E+00	0.00E+00	0.00E+00	0.00E+00	0.00E+00	0.00E+00	0.00E+00	0.00E+00
Cs 134	8.88E+08	1.65E+08	3.09E+07	5.79E+06	1.08E+06	3.76E+04	1.31E+03	4.55E+01	5.52E-02	2.35E-06	0.00E+00	0.00E+00	0.00E+00	0.00E+00	0.00E+00	0.00E+00	0.00E+00	0.00E+00
Cs 135	1.82E+02	1.83E+02	1.83E+02	1.83E+02	1.83E+02	1.83E+02	1.83E+02	1.83E+02	1.83E+02	1.83E+02	1.83E+02	1.83E+02	1.83E+02	1.83E+02	1.83E+02	1.78E+02	1.36E+02	8.99E+00
Cs 137	5.08E+07	4.53E+07	4.03E+07	3.59E+07	3.20E+07	2.54E+07	2.02E+07	1.60E+07	1.01E+07	5.07E+06	5.06E+05	5.05E+04	5.03E+02	4.98E-03	0.00E+00	0.00E+00	0.00E+00	0.00E+00
Ba 133	1.16E+05	8.34E+04	5.99E+04	4.31E+04	3.10E+04	1.60E+04	8.30E+03	4.29E+03	1.15E+03	1.59E+02	2.18E-01	2.99E-04	5.62E-10	0.00E+00	0.00E+00	0.00E+00	0.00E+00	0.00E+00
Ba 137m	5.52E+07	4.29E+07	3.82E+07	3.40E+07	3.03E+07	2.41E+07	1.91E+07	1.52E+07	9.58E+06	4.80E+06	4.79E+05	4.78E+04	4.76E+02	4.72E-03	0.00E+00	0.00E+00	0.00E+00	0.00E+00
La 137	7.03E+00	7.03E+00	7.03E+00	7.03E+00	7.08E+00	7.05E+00	7.05E+00	7.05E+00	7.03E+00	7.05E+00	7.02E+00	7.03E+00	7.03E+00	6.99E+00	6.27E+00	2.22E+00	6.76E-05	0.00E+00
La 138	5.72E-05	5.72E-05	5.72E-05	5.72E-05	5.72E-05	5.72E-05	5.72E-05	5.72E-05	5.72E-05	5.72E-05	5.72E-05	5.72E-05	5.72E-05	5.72E-05	5.72E-05	5.72E-05	5.72E-05	5.72E-05
Ce 139	1.27E+05	1.29E+01	1.30E-03	1.32E-07	1.34E-11	0.00E+00	0.00E+00	0.00E+00	0.00E+00	0.00E+00	0.00E+00	0.00E+00	0.00E+00	0.00E+00	0.00E+00	0.00E+00	0.00E+00	0.00E+00
Ce 141	2.76E+09	3.39E-08	0.00E+00	0.00E+00	0.00E+00	0.00E+00	0.00E+00	0.00E+00	0.00E+00	0.00E+00	0.00E+00	0.00E+00	0.00E+00	0.00E+00	0.00E+00	0.00E+00	0.00E+00	0.00E+00
Ce 144	1.08E+09	1.27E+07	1.49E+05	1.75E+03	2.06E+01	2.84E-03	3.93E-07	5.43E-11	0.00E+00	0.00E+00	0.00E+00	0.00E+00	0.00E+00	0.00E+00	0.00E+00	0.00E+00	0.00E+00	0.00E+00
Pr 144	1.12E+09	1.27E+07	1.49E+05	1.75E+03	2.06E+01	2.84E-03	3.93E-07	5.43E-11	0.00E+00	0.00E+00	0.00E+00	0.00E+00	0.00E+00	0.00E+00	0.00E+00	0.00E+00	0.00E+00	0.00E+00
Pr 144m	4.13E+07	1.21E+05	1.42E+03	1.67E+01	1.96E-01	2.71E-05	3.75E-09	5.18E-13	0.00E+00	0.00E+00	0.00E+00	0.00E+00	0.00E+00	0.00E+00	0.00E+00	0.00E+00	0.00E+00	0.00E+00
Nd 144	7.21E-07	1.08E-06	1.09E-06	1.09E-06	1.09E-06	1.09E-06	1.09E-06	1.09E-06	1.09E-06	1.09E-06	1.09E-06	1.09E-06	1.09E-06	1.09E-06	1.09E-06	1.09E-06	1.09E-06	1.09E-06
Nd 150	4.96E-11	4.96E-11	4.96E-11	4.96E-11	4.96E-11	4.96E-11	4.96E-11	4.96E-11	4.96E-11	4.96E-11	4.96E-11	4.96E-11	4.96E-11	4.96E-11	4.96E-11	4.96E-11	4.96E-11	4.96E-11
Pm 143	8.69E-01	7.34E-03	6.16E-05	5.22E-07	4.38E-09	3.10E-13	2.20E-17	1.56E-21	0.00E+00	0.00E+00	0.00E+00	0.00E+00	0.00E+00	0.00E+00	0.00E+00	0.00E+00	0.00E+00	0.00E+00
Pm 144	9.47E+00	2.86E-01	8.84E-03	2.69E-04	8.24E-06	7.71E-09	7.22E-12	6.77E-15	5.90E-21	0.00E+00	0.00E+00	0.00E+00	0.00E+00	0.00E+00	0.00E+00	0.00E+00	0.00E+00	0.00E+00
Pm 145	1.98E+03	7.57E+03	6.35E+03	5.25E+03	4.29E+03	2.93E+03	1.97E+03	1.33E+03	6.10E+02	1.88E+02	3.72E+00	7.42E-02	2.99E-05	9.21E-14	0.00E+00	0.00E+00	0.00E+00	0.00E+00
Pm 146	4.64E+01	2.48E+01	1.32E+01	7.07E+00	3.78E+00	1.08E+00	3.08E-01	8.79E-02	7.17E-03	1.67E-04	5.97E-10	2.16E-15	0.00E+00	0.00E+00	0.00E+00	0.00E+00	0.00E+00	0.00E+00
Pm 147	1.28E+08	3.72E+07	9.93E+06	2.65E+06	7.07E+05	5.03E+04	3.58E+03	2.55E+02	1.29E+00	4.66E-04	0.00E+00	0.00E+00	0.00E+00	0.00E+00	0.00E+00	0.00E+00	0.00E+00	0.00E+00
Pm 148	1.85E+08	2.75E-08	0.00E+00	0.00E+00	0.00E+00	0.00E+00	0.00E+00	0.00E+00	0.00E+00	0.00E+00	0.00E+00	0.00E+00	0.00E+00	0.00E+00	0.00E+00	0.00E+00	0.00E+00	0.00E+00
Pm 148m	1.18E+07	5.70E-07	0.00E+00	0.00E+00	0.00E+00	0.00E+00	0.00E+00	0.00E+00	0.00E+00	0.00E+00	0.00E+00	0.00E+00	0.00E+00	0.00E+00	0.00E+00	0.00E+00	0.00E+00	0.00E+00
Sm 145	1.34E+05	3.24E+03	7.82E+01	1.89E+00	4.58E-02	2.66E-05	1.55E-08	9.06E-12	0.00E+00	0.00E+00	0.00E+00	0.00E+00	0.00E+00	0.00E+00	0.00E+00	0.00E+00	0.00E+00	0.00E+00
Sm 146	5.07E-04	5.07E-04	5.07E-04	5.07E-04	5.08E-04	5.08E-04	5.08E-04	5.08E-04	5.08E-04	5.08E-04	5.08E-04	5.08E-04	5.08E-04	5.08E-04	5.08E-04	5.07E-04	5.05E-04	4.74E-04
Sm 147	2.27E-03	4.80E-03	5.48E-03	5.66E-03	5.70E-03	5.72E-03	5.72E-03	5.72E-03	5.72E-03	5.72E-03	5.72E-03	5.72E-03	5.72E-03	5.72E-03	5.72E-03	5.72E-03	5.72E-03	5.72E-03
Sm 148	4.23E-08	4.29E-08	4.29E-08	4.29E-08	4.29E-08	4.29E-08	4.29E-08	4.29E-08	4.29E-08	4.29E-08	4.29E-08	4.29E-08	4.29E-08	4.29E-08	4.29E-08	4.29E-08	4.29E-08	4.29E-08
Sm 151	1.29E+05	1.37E+05	1.31E+05	1.26E+05	1.22E+05	1.12E+05	1.04E+05	9.64E+04	8.27E+04	6.56E+04	3.04E+04	1.41E+04	3.01E+03	6.40E+01	0.00E+00	0.00E+00	0.00E+00	0.00E+00
Eu 148	6.20E-07	5.09E-17	0.00E+00	0.00E+00	0.00E+00	0.00E+00	0.00E+00	0.00E+00	0.00E+00	0.00E+00	0.00E+00	0.00E+00	0.00E+00	0.00E+00	0.00E+00	0.00E+00	0.00E+00	0.00E+00
Eu 149	4.72E-02	5.90E-08	7.33E-14	9.08E-20	0.00E+00	0.00E+00	0.00E+00	0.00E+00	0.00E+00	0.00E+00	0.00E+00	0.00E+00	0.00E+00	0.00E+00	0.00E+00	0.00E+00	0.00E+00	0.00E+00
Eu 150	9.01E-01	8.22E-01	7.46E-01	6.80E-01	6.17E-01	5.11E-01	4.24E-01	3.53E-01	2.42E-01	1.38E-01	2.10E-02	3.22E-03	7.52E-05	6.24E-09	0.00E+00	0.00E+00	0.00E+00	0.00E+00
Eu 152	1.78E+02	1.37E+02	1.06E+02	8.23E+01	6.37E+01	3.82E+01	2.29E+01	1.37E+01	4.92E+00	1.06E+00	6.32E-03	3.77E-05	1.35E-09	0.00E+00	0.00E+00	0.00E+00	0.00E+00	0.00E+00
Eu 154	1.22E+07	8.15E+06	5.44E+06	3.63E+06	2.43E+06	1.09E+06	4.84E+05	2.16E+05	4.33E+04	3.87E+03	1.22E+00	3.82E-04	3.84E-11	0.00E+00	0.00E+00	0.00E+00	0.00E+00	0.00E+00

Table 28: Zircaloy Cladding - Total Radionuclide Activity (Bq/Initial kg Zr)

220 MWh/kgU, 720 kW/bundle

Nuclide	0.0 Yrs	5.0 Yrs	10.0 Yrs	15.0 Yrs	20.0 Yrs	30.0 Yrs	40.0 Yrs	50.0 Yrs	70.0 Yrs	100.0 Yrs	200.0 Yrs	300.0 Yrs	500.0 Yrs	1.0E3 Yrs	1.0E4 Yrs	1.0E5 Yrs	1.0E6 Yrs	1.0E7 Yrs	
Ta 182	9.49E+10	1.53E+06	3.40E+02	3.15E+02	3.15E+02	3.15E+02	3.15E+02	3.15E+02	3.15E+02	3.15E+02	3.15E+02	3.15E+02	3.15E+02	3.15E+02	3.15E+02	3.15E+02	3.13E+02	2.92E+02	1.45E+02
W 180	3.73E-09	3.73E-09	3.73E-09	3.73E-09	3.73E-09	3.73E-09	3.73E-09	3.73E-09	3.73E-09	3.73E-09	3.73E-09	3.73E-09	3.73E-09	3.73E-09	3.73E-09	3.73E-09	3.73E-09	3.73E-09	3.73E-09
W 181	1.24E+09	3.60E+04	1.05E+00	3.05E-05	8.86E-10	0.00E+00	0.00E+00	0.00E+00	0.00E+00	0.00E+00	0.00E+00	0.00E+00	0.00E+00	0.00E+00	0.00E+00	0.00E+00	0.00E+00	0.00E+00	0.00E+00
W 185	2.57E+10	1.23E+03	5.86E-05	0.00E+00	0.00E+00	0.00E+00	0.00E+00	0.00E+00	0.00E+00	0.00E+00	0.00E+00	0.00E+00	0.00E+00	0.00E+00	0.00E+00	0.00E+00	0.00E+00	0.00E+00	0.00E+00
W 186	9.12E-09	9.12E-09	9.12E-09	9.12E-09	9.12E-09	9.12E-09	9.12E-09	9.12E-09	9.12E-09	9.12E-09	9.12E-09	9.12E-09	9.12E-09	9.12E-09	9.12E-09	9.12E-09	9.12E-09	9.12E-09	9.12E-09
W 188	9.34E+08	1.23E+01	1.63E-07	0.00E+00	0.00E+00	0.00E+00	0.00E+00	0.00E+00	0.00E+00	0.00E+00	0.00E+00	0.00E+00	0.00E+00	0.00E+00	0.00E+00	0.00E+00	0.00E+00	0.00E+00	0.00E+00
Re 183	1.00E+02	1.40E-06	1.96E-14	0.00E+00	0.00E+00	0.00E+00	0.00E+00	0.00E+00	0.00E+00	0.00E+00	0.00E+00	0.00E+00	0.00E+00	0.00E+00	0.00E+00	0.00E+00	0.00E+00	0.00E+00	0.00E+00
Re 184m	1.33E+03	7.42E-01	4.14E-04	2.31E-07	1.29E-10	4.01E-17	0.00E+00	0.00E+00	0.00E+00	0.00E+00	0.00E+00	0.00E+00	0.00E+00	0.00E+00	0.00E+00	0.00E+00	0.00E+00	0.00E+00	0.00E+00
Re 184	1.72E+04	6.99E-01	3.90E-04	2.18E-07	1.21E-10	0.00E+00	0.00E+00	0.00E+00	0.00E+00	0.00E+00	0.00E+00	0.00E+00	0.00E+00	0.00E+00	0.00E+00	0.00E+00	0.00E+00	0.00E+00	0.00E+00
Re 186m	1.14E+01	1.14E+01	1.14E+01	1.14E+01	1.14E+01	1.14E+01	1.14E+01	1.14E+01	1.14E+01	1.14E+01	1.14E+01	1.14E+01	1.14E+01	1.13E+01	1.13E+01	1.10E+01	8.04E+00	3.55E-01	1.01E-14
Re 186	7.36E+09	1.14E+01	1.14E+01	1.14E+01	1.14E+01	1.14E+01	1.14E+01	1.14E+01	1.14E+01	1.14E+01	1.14E+01	1.14E+01	1.14E+01	1.13E+01	1.13E+01	1.10E+01	8.04E+00	3.55E-01	0.00E+00
Re 187	4.81E+00	4.84E+00	4.84E+00	4.84E+00	4.84E+00	4.84E+00	4.84E+00	4.84E+00	4.84E+00	4.84E+00	4.84E+00	4.84E+00	4.84E+00	4.84E+00	4.84E+00	4.84E+00	4.84E+00	4.84E+00	4.84E+00
Re 188	9.91E+10	1.25E+01	1.65E-07	0.00E+00	0.00E+00	0.00E+00	0.00E+00	0.00E+00	0.00E+00	0.00E+00	0.00E+00	0.00E+00	0.00E+00	0.00E+00	0.00E+00	0.00E+00	0.00E+00	0.00E+00	0.00E+00
Os 185	1.04E+06	1.42E+00	1.93E-06	2.53E-12	0.00E+00	0.00E+00	0.00E+00	0.00E+00	0.00E+00	0.00E+00	0.00E+00	0.00E+00	0.00E+00	0.00E+00	0.00E+00	0.00E+00	0.00E+00	0.00E+00	0.00E+00
Os 186	6.85E-07	7.19E-07	7.19E-07	7.19E-07	7.19E-07	7.19E-07	7.19E-07	7.19E-07	7.19E-07	7.19E-07	7.19E-07	7.19E-07	7.19E-07	7.19E-07	7.18E-07	7.18E-07	7.22E-07	7.22E-07	7.22E-07
Os 194	1.31E+03	7.43E+02	4.32E+02	2.34E+02	1.31E+02	4.30E+01	1.31E+01	4.00E+00	4.12E-01	1.28E-02	1.23E-07	1.19E-12	0.00E+00	0.00E+00	0.00E+00	0.00E+00	0.00E+00	0.00E+00	0.00E+00
Ir 192	8.15E+08	2.91E+01	1.04E-06	0.00E+00	0.00E+00	0.00E+00	0.00E+00	0.00E+00	0.00E+00	0.00E+00	0.00E+00	0.00E+00	0.00E+00	0.00E+00	0.00E+00	0.00E+00	0.00E+00	0.00E+00	0.00E+00
Ir 194	7.09E+09	7.72E+02	4.00E+02	2.36E+02	1.31E+02	4.30E+01	1.31E+01	4.21E+00	4.09E-01	1.26E-02	1.22E-07	1.17E-12	0.00E+00	0.00E+00	0.00E+00	0.00E+00	0.00E+00	0.00E+00	0.00E+00
Pt 190	1.44E-05	1.44E-05	1.44E-05	1.44E-05	1.44E-05	1.44E-05	1.44E-05	1.44E-05	1.44E-05	1.44E-05	1.44E-05	1.44E-05	1.44E-05	1.44E-05	1.44E-05	1.44E-05	1.44E-05	1.44E-05	1.44E-05
Pt 193	1.27E+06	1.20E+06	1.12E+06	1.04E+06	9.72E+05	8.46E+05	7.37E+05	6.41E+05	4.86E+05	3.21E+05	8.01E+04	2.00E+04	1.25E+03	1.22E+00	0.00E+00	0.00E+00	0.00E+00	0.00E+00	0.00E+00
Au 194	3.02E-04	4.11E-06	4.09E-06	4.03E-06	4.01E-06	3.96E-06	3.88E-06	3.83E-06	3.70E-06	3.53E-06	3.01E-06	2.58E-06	1.89E-06	8.70E-07	6.83E-13	0.00E+00	0.00E+00	0.00E+00	0.00E+00
Au 195	8.73E+01	9.71E-02	1.08E-04	1.20E-07	1.33E-10	1.64E-16	0.00E+00	0.00E+00	0.00E+00	0.00E+00	0.00E+00	0.00E+00	0.00E+00	0.00E+00	0.00E+00	0.00E+00	0.00E+00	0.00E+00	0.00E+00
Hg 194	4.13E-06	4.11E-06	4.09E-06	4.03E-06	4.01E-06	3.96E-06	3.88E-06	3.83E-06	3.70E-06	3.53E-06	3.01E-06	2.58E-06	1.89E-06	8.70E-07	6.83E-13	0.00E+00	0.00E+00	0.00E+00	0.00E+00
Hg 203	9.31E+07	1.48E-04	0.00E+00	0.00E+00	0.00E+00	0.00E+00	0.00E+00	0.00E+00	0.00E+00	0.00E+00	0.00E+00	0.00E+00	0.00E+00	0.00E+00	0.00E+00	0.00E+00	0.00E+00	0.00E+00	0.00E+00
Hg 206	9.75E+01	7.70E-09	6.59E-09	5.63E-09	4.82E-09	3.53E-09	2.59E-09	1.91E-09	1.05E-09	4.94E-10	5.23E-10	1.55E-09	4.23E-09	1.62E-08	6.51E-07	5.83E-06	1.09E-05	1.07E-05	1.07E-05
Tl 202	2.62E+04	1.82E-03	1.82E-03	1.82E-03	1.82E-03	1.82E-03	1.82E-03	1.82E-03	1.82E-03	1.82E-03	1.82E-03	1.82E-03	1.82E-03	1.81E-03	1.80E-03	1.60E-03	4.87E-04	3.36E-09	0.00E+00
Tl 204	1.33E+07	5.44E+06	2.13E+06	8.24E+05	3.43E+05	5.50E+04	8.76E+03	1.40E+03	3.59E+01	1.48E-01	1.62E-09	0.00E+00	0.00E+00	0.00E+00	0.00E+00	0.00E+00	0.00E+00	0.00E+00	0.00E+00
Tl 206	3.64E+06	2.90E-01	2.90E-01	2.90E-01	2.90E-01	2.90E-01	2.90E-01	2.90E-01	2.90E-01	2.90E-01	2.90E-01	2.90E-01	2.90E-01	2.90E-01	2.93E-01	2.90E-01	2.85E-01	2.33E-01	3.04E-02
Pb 202	1.82E-03	1.82E-03	1.82E-03	1.82E-03	1.82E-03	1.82E-03	1.82E-03	1.82E-03	1.82E-03	1.82E-03	1.82E-03	1.82E-03	1.81E-03	1.80E-03	1.60E-03	4.87E-04	3.36E-09	0.00E+00	0.00E+00
Pb 204	7.04E-07	7.04E-07	7.04E-07	7.04E-07	7.04E-07	7.04E-07	7.04E-07	7.04E-07	7.04E-07	7.04E-07	7.04E-07	7.04E-07	7.04E-07	7.04E-07	7.04E-07	7.04E-07	7.04E-07	7.04E-07	7.04E-07
Pb 205	1.10E+01	1.10E+01	1.10E+01	1.10E+01	1.10E+01	1.10E+01	1.10E+01	1.10E+01	1.10E+01	1.10E+01	1.10E+01	1.10E+01	1.10E+01	1.10E+01	1.10E+01	1.10E+01	1.10E+01	1.06E+01	7.39E+00
Pb 209	9.07E-01	1.42E-01	2.08E-01	2.73E-01	3.39E-01	4.71E-01	6.02E-01	7.33E-01	9.95E-01	1.39E+00	2.69E+00	3.97E+00	6.51E+00	1.27E+01	8.86E+01	2.25E+02	2.91E+02	1.49E+01	1.49E+01

Table 28: Zircaloy Cladding - Total Radionuclide Activity (Bq/Initial kg Zr)

220 MWh/kgU, 720 kW/bundle

Nuclide	0.0 Yrs	5.0 Yrs	10.0 Yrs	15.0 Yrs	20.0 Yrs	30.0 Yrs	40.0 Yrs	50.0 Yrs	70.0 Yrs	100.0 Yrs	200.0 Yrs	300.0 Yrs	500.0 Yrs	1.0E3 Yrs	1.0E4 Yrs	1.0E5 Yrs	1.0E6 Yrs	1.0E7 Yrs
Pb 210	4.67E-01	4.05E-01	3.47E-01	2.97E-01	2.54E-01	1.86E-01	1.36E-01	1.00E-01	5.53E-02	2.60E-02	2.76E-02	8.14E-02	2.23E-01	8.55E-01	3.43E+01	3.07E+02	5.73E+02	5.62E+02
Pb 211	3.62E-01	7.25E+00	1.31E+01	1.80E+01	2.23E+01	2.90E+01	3.38E+01	3.73E+01	4.18E+01	4.48E+01	4.66E+01	4.66E+01	4.64E+01	4.60E+01	3.94E+01	1.80E+01	1.60E+01	1.59E+01
Pb 212	1.83E+03	1.37E+04	1.49E+04	1.45E+04	1.39E+04	1.25E+04	1.13E+04	1.03E+04	8.39E+03	6.20E+03	2.27E+03	8.29E+02	1.11E+02	8.14E-01	8.98E-02	9.08E-02	1.01E-01	1.86E-01
Pb 214	5.46E-06	4.25E-05	1.23E-04	2.48E-04	4.17E-04	8.87E-04	1.54E-03	2.36E-03	4.55E-03	9.19E-03	3.64E-02	8.14E-02	2.23E-01	8.54E-01	3.43E+01	3.07E+02	5.72E+02	5.62E+02
Bi 207	3.70E+00	3.35E+00	2.98E+00	2.67E+00	2.40E+00	1.91E+00	1.54E+00	1.23E+00	7.97E-01	4.10E-01	4.58E-02	5.11E-03	6.27E-05	1.06E-09	0.00E+00	0.00E+00	0.00E+00	0.00E+00
Bi 208	5.25E-01	5.25E-01	5.25E-01	5.25E-01	5.25E-01	5.25E-01	5.25E-01	5.24E-01	5.25E-01	5.25E-01	5.25E-01	5.25E-01	5.25E-01	5.25E-01	5.16E-01	4.34E-01	8.00E-02	3.44E-09
Bi 209	1.26E-09	1.26E-09	1.26E-09	1.26E-09	1.26E-09	1.26E-09	1.26E-09	1.26E-09	1.26E-09	1.26E-09	1.26E-09	1.26E-09	1.26E-09	1.26E-09	1.26E-09	1.26E-09	1.27E-09	1.27E-09
Bi 210m	2.90E-01	2.90E-01	2.90E-01	2.90E-01	2.90E-01	2.90E-01	2.90E-01	2.90E-01	2.90E-01	2.90E-01	2.90E-01	2.90E-01	2.90E-01	2.93E-01	2.90E-01	2.85E-01	2.32E-01	2.96E-02
Bi 210	4.23E+06	4.05E-01	3.47E-01	2.97E-01	2.54E-01	1.86E-01	1.36E-01	1.00E-01	5.54E-02	2.60E-02	2.76E-02	8.14E-02	2.23E-01	8.55E-01	3.43E+01	3.07E+02	5.73E+02	5.62E+02
Po 208	1.77E-03	5.35E-04	1.62E-04	4.92E-05	1.49E-05	1.36E-06	1.24E-07	1.13E-08	9.48E-11	7.23E-14	0.00E+00	0.00E+00	0.00E+00	0.00E+00	0.00E+00	0.00E+00	0.00E+00	0.00E+00
Po 209	7.33E-02	7.09E-02	6.87E-02	6.65E-02	6.41E-02	5.98E-02	5.60E-02	5.24E-02	4.54E-02	3.71E-02	1.88E-02	9.58E-03	2.45E-03	8.20E-05	0.00E+00	0.00E+00	0.00E+00	0.00E+00
Po 210	2.78E+06	3.18E+02	3.80E-01	2.97E-01	2.54E-01	1.86E-01	1.36E-01	1.00E-01	5.54E-02	2.60E-02	2.76E-02	8.14E-02	2.23E-01	8.55E-01	3.43E+01	3.07E+02	5.73E+02	5.62E+02
Po 211	1.00E-03	2.00E-02	3.61E-02	4.98E-02	6.15E-02	7.99E-02	9.33E-02	1.03E-01	1.15E-01	1.24E-01	1.29E-01	1.29E-01	1.28E-01	1.27E-01	1.09E-01	4.97E-02	4.42E-02	4.38E-02
Po 212	1.17E+03	8.76E+03	9.57E+03	9.30E+03	8.88E+03	8.03E+03	7.26E+03	6.57E+03	5.37E+03	3.97E+03	1.45E+03	5.31E+02	7.10E+01	5.21E-01	5.75E-02	5.82E-02	6.45E-02	1.19E-01
Po 213	8.85E-01	1.39E-01	2.03E-01	2.67E-01	3.32E-01	4.60E-01	5.89E-01	7.17E-01	9.73E-01	1.36E+00	2.63E+00	3.88E+00	6.37E+00	1.24E+01	8.66E+01	2.20E+02	2.85E+02	1.45E+01
Po 214	1.60E+00	4.25E-05	1.23E-04	2.48E-04	4.17E-04	8.87E-04	1.54E-03	2.36E-03	4.55E-03	9.19E-03	3.64E-02	8.14E-02	2.23E-01	8.54E-01	3.43E+01	3.07E+02	5.72E+02	5.62E+02
Po 215	3.61E-01	7.25E+00	1.31E+01	1.80E+01	2.23E+01	2.90E+01	3.38E+01	3.73E+01	4.18E+01	4.48E+01	4.66E+01	4.66E+01	4.64E+01	4.60E+01	3.94E+01	1.80E+01	1.60E+01	1.59E+01
Po 216	1.83E+03	1.37E+04	1.49E+04	1.45E+04	1.39E+04	1.25E+04	1.13E+04	1.03E+04	8.39E+03	6.20E+03	2.27E+03	8.29E+02	1.11E+02	8.14E-01	8.98E-02	9.08E-02	1.01E-01	1.86E-01
Po 218	5.46E-06	4.25E-05	1.23E-04	2.48E-04	4.17E-04	8.87E-04	1.54E-03	2.36E-03	4.56E-03	9.19E-03	3.64E-02	8.14E-02	2.23E-01	8.55E-01	3.43E+01	3.07E+02	5.73E+02	5.62E+02
Tl 207	3.61E-01	7.23E+00	1.30E+01	1.80E+01	2.22E+01	2.89E+01	3.37E+01	3.73E+01	4.17E+01	4.47E+01	4.65E+01	4.65E+01	4.63E+01	4.59E+01	3.92E+01	1.80E+01	1.60E+01	1.58E+01
Tl 208	6.57E+02	4.91E+03	5.37E+03	5.22E+03	4.98E+03	4.51E+03	4.08E+03	3.69E+03	3.01E+03	2.23E+03	8.15E+02	2.98E+02	3.99E+01	2.93E-01	3.23E-02	3.26E-02	3.62E-02	6.68E-02
Tl 209	1.99E-02	3.12E-03	4.57E-03	6.02E-03	7.46E-03	1.04E-02	1.32E-02	1.61E-02	2.19E-02	3.05E-02	5.91E-02	8.74E-02	1.43E-01	2.78E-01	1.95E+00	4.94E+00	6.40E+00	3.27E-01
Tl 210	1.99E-09	8.93E-09	2.59E-08	5.20E-08	8.75E-08	1.86E-07	3.23E-07	4.96E-07	9.57E-07	1.93E-06	7.64E-06	1.71E-05	4.68E-05	1.79E-04	7.19E-03	6.44E-02	1.20E-01	1.18E-01
Bi 211	3.62E-01	7.25E+00	1.31E+01	1.80E+01	2.23E+01	2.90E+01	3.38E+01	3.73E+01	4.18E+01	4.48E+01	4.66E+01	4.66E+01	4.64E+01	4.60E+01	3.94E+01	1.80E+01	1.60E+01	1.59E+01
Bi 212	1.83E+03	1.37E+04	1.49E+04	1.45E+04	1.39E+04	1.25E+04	1.13E+04	1.03E+04	8.39E+03	6.20E+03	2.27E+03	8.29E+02	1.11E+02	8.14E-01	8.98E-02	9.08E-02	1.01E-01	1.86E-01
Bi 213	9.05E-01	1.42E-01	2.08E-01	2.73E-01	3.39E-01	4.71E-01	6.02E-01	7.33E-01	9.95E-01	1.39E+00	2.69E+00	3.97E+00	6.51E+00	1.27E+01	8.86E+01	2.25E+02	2.91E+02	1.49E+01
Bi 214	5.46E-06	4.25E-05	1.23E-04	2.48E-04	4.17E-04	8.87E-04	1.54E-03	2.36E-03	4.56E-03	9.19E-03	3.64E-02	8.14E-02	2.23E-01	8.55E-01	3.43E+01	3.07E+02	5.73E+02	5.62E+02
At 217	9.05E-01	1.42E-01	2.08E-01	2.73E-01	3.39E-01	4.71E-01	6.02E-01	7.33E-01	9.95E-01	1.39E+00	2.69E+00	3.97E+00	6.51E+00	1.27E+01	8.86E+01	2.25E+02	2.91E+02	1.49E+01
At 218	1.09E-09	8.51E-09	2.46E-08	4.96E-08	8.33E-08	1.78E-07	3.07E-07	4.73E-07	9.11E-07	1.84E-06	7.28E-06	1.63E-05	4.46E-05	1.71E-04	6.85E-03	6.13E-02	1.15E-01	1.12E-01
Rn 217	6.33E-05	9.93E-06	1.45E-05	1.91E-05	2.37E-05	3.30E-05	4.21E-05	5.13E-05	6.97E-05	9.71E-05	1.88E-04	2.78E-04	4.56E-04	8.86E-04	6.20E-03	1.57E-02	2.04E-02	1.04E-03
Rn 218	1.60E+00	8.51E-12	2.46E-11	4.96E-11	8.33E-11	1.78E-10	3.07E-10	4.73E-10	9.11E-10	1.84E-09	7.28E-09	1.63E-08	4.46E-08	1.71E-07	6.85E-06	6.13E-05	1.15E-04	1.12E-04
Rn 219	3.61E-01	7.25E+00	1.31E+01	1.80E+01	2.23E+01	2.90E+01	3.38E+01	3.73E+01	4.18E+01	4.48E+01	4.66E+01	4.66E+01	4.64E+01	4.60E+01	3.94E+01	1.80E+01	1.60E+01	1.59E+01
Rn 220	1.83E+03	1.37E+04	1.49E+04	1.45E+04	1.39E+04	1.25E+04	1.13E+04	1.03E+04	8.39E+03	6.20E+03	2.27E+03	8.29E+02	1.11E+02	8.14E-01	8.98E-02	9.08E-02	1.01E-01	1.86E-01
Rn 222	5.46E-06	4.25E-05	1.23E-04	2.48E-04	4.17E-04	8.87E-04	1.54E-03	2.36E-03	4.56E-03	9.19E-03	3.64E-02	8.14E-02	2.23E-01	8.55E-01	3.43E+01	3.07E+02	5.73E+02	5.62E+02

Table 28: Zircaloy Cladding - Total Radionuclide Activity (Bq/Initial kg Zr)

220 MWh/kgU, 720 kW/bundle

Nuclide	0.0 Yrs	5.0 Yrs	10.0 Yrs	15.0 Yrs	20.0 Yrs	30.0 Yrs	40.0 Yrs	50.0 Yrs	70.0 Yrs	100.0 Yrs	200.0 Yrs	300.0 Yrs	500.0 Yrs	1.0E3 Yrs	1.0E4 Yrs	1.0E5 Yrs	1.0E6 Yrs	1.0E7 Yrs
Fr 221	9.05E-01	1.42E-01	2.08E-01	2.73E-01	3.39E-01	4.71E-01	6.02E-01	7.33E-01	9.95E-01	1.39E+00	2.69E+00	3.97E+00	6.51E+00	1.27E+01	8.86E+01	2.25E+02	2.91E+02	1.49E+01
Fr 223	5.75E-03	1.00E-01	1.80E-01	2.49E-01	3.07E-01	4.00E-01	4.67E-01	5.16E-01	5.77E-01	6.19E-01	6.43E-01	6.43E-01	6.41E-01	6.35E-01	5.43E-01	2.49E-01	2.21E-01	2.19E-01
Ra 223	3.61E-01	7.25E+00	1.31E+01	1.80E+01	2.23E+01	2.90E+01	3.38E+01	3.73E+01	4.18E+01	4.48E+01	4.66E+01	4.66E+01	4.64E+01	4.60E+01	3.94E+01	1.80E+01	1.60E+01	1.59E+01
Ra 224	1.83E+03	1.37E+04	1.49E+04	1.45E+04	1.39E+04	1.25E+04	1.13E+04	1.03E+04	8.39E+03	6.20E+03	2.27E+03	8.29E+02	1.11E+02	8.14E-01	8.98E-02	9.08E-02	1.01E-01	1.86E-01
Ra 225	1.14E+00	1.42E-01	2.08E-01	2.73E-01	3.39E-01	4.71E-01	6.02E-01	7.33E-01	9.95E-01	1.39E+00	2.69E+00	3.97E+00	6.51E+00	1.27E+01	8.86E+01	2.25E+02	2.91E+02	1.49E+01
Ra 226	5.83E-06	4.25E-05	1.23E-04	2.48E-04	4.17E-04	8.87E-04	1.54E-03	2.36E-03	4.56E-03	9.19E-03	3.64E-02	8.14E-02	2.23E-01	8.55E-01	3.43E+01	3.07E+02	5.73E+02	5.62E+02
Ra 228	9.42E-03	4.58E-02	6.57E-02	7.66E-02	8.25E-02	8.76E-02	8.91E-02	8.95E-02	8.97E-02	8.97E-02	8.97E-02	8.97E-02	8.97E-02	8.97E-02	8.98E-02	9.08E-02	1.01E-01	1.86E-01
Ac 225	9.04E-01	1.42E-01	2.08E-01	2.73E-01	3.39E-01	4.71E-01	6.02E-01	7.33E-01	9.95E-01	1.39E+00	2.69E+00	3.97E+00	6.51E+00	1.27E+01	8.86E+01	2.25E+02	2.91E+02	1.49E+01
Ac 227	4.17E-01	7.25E+00	1.31E+01	1.80E+01	2.23E+01	2.90E+01	3.38E+01	3.73E+01	4.18E+01	4.48E+01	4.66E+01	4.66E+01	4.64E+01	4.60E+01	3.94E+01	1.80E+01	1.60E+01	1.59E+01
Ac 228	5.46E+01	4.58E-02	6.57E-02	7.66E-02	8.25E-02	8.76E-02	8.91E-02	8.95E-02	8.97E-02	8.97E-02	8.97E-02	8.97E-02	8.97E-02	8.97E-02	8.98E-02	9.08E-02	1.01E-01	1.86E-01
Th 227	3.64E-01	7.15E+00	1.29E+01	1.78E+01	2.20E+01	2.86E+01	3.34E+01	3.69E+01	4.12E+01	4.42E+01	4.60E+01	4.60E+01	4.58E+01	4.54E+01	3.88E+01	1.78E+01	1.58E+01	1.57E+01
Th 228	1.89E+03	1.37E+04	1.49E+04	1.45E+04	1.39E+04	1.25E+04	1.13E+04	1.03E+04	8.39E+03	6.20E+03	2.27E+03	8.29E+02	1.11E+02	8.14E-01	8.98E-02	9.08E-02	1.01E-01	1.86E-01
Th 229	7.63E-02	1.42E-01	2.08E-01	2.73E-01	3.39E-01	4.71E-01	6.02E-01	7.33E-01	9.95E-01	1.39E+00	2.69E+00	3.97E+00	6.51E+00	1.27E+01	8.86E+01	2.25E+02	2.91E+02	1.49E+01
Th 230	6.80E-03	2.71E-02	4.75E-02	6.80E-02	8.86E-02	1.30E-01	1.72E-01	2.14E-01	2.99E-01	4.29E-01	8.71E-01	1.32E+00	2.24E+00	4.52E+00	4.40E+01	3.07E+02	5.73E+02	5.62E+02
Th 231	8.82E+04	6.26E+00	6.26E+00	6.26E+00	6.26E+00	6.26E+00	6.27E+00	6.27E+00	6.28E+00	6.28E+00	6.31E+00	6.34E+00	6.40E+00	6.53E+00	8.70E+00	1.55E+01	1.60E+01	1.59E+01
Th 232	8.97E-02	8.97E-02	8.97E-02	8.97E-02	8.97E-02	8.97E-02	8.97E-02	8.97E-02	8.97E-02	8.97E-02	8.97E-02	8.97E-02	8.97E-02	8.97E-02	8.98E-02	9.08E-02	1.01E-01	1.86E-01
Th 234	2.48E+04	5.63E+02	5.63E+02	5.63E+02	5.63E+02	5.63E+02	5.63E+02	5.63E+02	5.63E+02	5.63E+02	5.63E+02	5.63E+02	5.63E+02	5.63E+02	5.63E+02	5.63E+02	5.63E+02	5.62E+02
Pa 231	4.68E+01	4.68E+01	4.68E+01	4.68E+01	4.68E+01	4.68E+01	4.68E+01	4.68E+01	4.68E+01	4.67E+01	4.67E+01	4.66E+01	4.64E+01	4.60E+01	3.93E+01	1.80E+01	1.60E+01	1.59E+01
Pa 232	2.19E+06	1.69E-07	1.68E-07	1.68E-07	1.68E-07	1.68E-07	1.68E-07	1.68E-07	1.68E-07	1.68E-07	1.68E-07	1.68E-07	1.68E-07	1.68E-07	1.61E-07	1.07E-07	1.82E-09	0.00E+00
Pa 233	7.54E+07	4.47E+01	4.55E+01	4.67E+01	4.83E+01	5.19E+01	5.61E+01	6.06E+01	7.00E+01	8.41E+01	1.27E+02	1.64E+02	2.22E+02	3.07E+02	3.76E+02	3.65E+02	2.73E+02	1.49E+01
Pa 234	1.28E+06	9.01E-01	9.01E-01	9.01E-01	9.01E-01	9.01E-01	9.01E-01	9.01E-01	9.01E-01	9.01E-01	9.01E-01	9.01E-01	9.01E-01	9.01E-01	9.01E-01	9.01E-01	9.01E-01	9.00E-01
Pa 234m	1.36E+06	5.63E+02	5.63E+02	5.63E+02	5.63E+02	5.63E+02	5.63E+02	5.63E+02	5.63E+02	5.63E+02	5.63E+02	5.63E+02	5.63E+02	5.63E+02	5.63E+02	5.63E+02	5.63E+02	5.62E+02
	0.00E+00	0.00E+00	0.00E+00	0.00E+00	0.00E+00	0.00E+00	0.00E+00	0.00E+00	0.00E+00	0.00E+00	0.00E+00	0.00E+00	0.00E+00	0.00E+00	0.00E+00	0.00E+00	0.00E+00	0.00E+00
U 232	1.64E+04	1.57E+04	1.49E+04	1.42E+04	1.35E+04	1.22E+04	1.10E+04	9.97E+03	8.15E+03	6.03E+03	2.20E+03	8.06E+02	1.08E+02	7.04E-01	1.10E-05	7.34E-06	1.24E-07	2.43E-25
U 233	1.05E+02	1.40E+02	1.40E+02	1.40E+02	1.40E+02	1.40E+02	1.40E+02	1.40E+02	1.40E+02	1.40E+02	1.40E+02	1.40E+02	1.40E+02	1.40E+02	1.49E+02	2.20E+02	2.91E+02	1.49E+01
U 234	4.40E+02	4.42E+02	4.45E+02	4.47E+02	4.49E+02	4.53E+02	4.57E+02	4.60E+02	4.66E+02	4.73E+02	4.88E+02	4.95E+02	5.00E+02	5.01E+02	5.03E+02	5.16E+02	5.59E+02	5.62E+02
U 235	6.26E+00	6.26E+00	6.26E+00	6.26E+00	6.26E+00	6.26E+00	6.27E+00	6.27E+00	6.28E+00	6.28E+00	6.31E+00	6.34E+00	6.40E+00	6.53E+00	8.70E+00	1.55E+01	1.60E+01	1.59E+01
U 236	8.89E+01	8.90E+01	8.91E+01	8.91E+01	8.92E+01	8.94E+01	8.95E+01	8.97E+01	8.99E+01	9.04E+01	9.18E+01	9.32E+01	9.60E+01	1.03E+02	1.78E+02	2.25E+02	2.19E+02	1.68E+02
U 237	3.28E+08	9.52E+02	7.47E+02	5.86E+02	4.60E+02	2.83E+02	1.74E+02	1.07E+02	4.07E+01	9.49E+00	7.42E-02	6.22E-04	4.15E-05	3.98E-05	1.91E-05	1.24E-08	0.00E+00	0.00E+00
U 238	5.63E+02	5.63E+02	5.63E+02	5.63E+02	5.63E+02	5.63E+02	5.63E+02	5.63E+02	5.63E+02	5.63E+02	5.63E+02	5.63E+02	5.63E+02	5.63E+02	5.63E+02	5.63E+02	5.63E+02	5.62E+02
U 240	7.18E+05	6.19E-05	6.19E-05	6.19E-05	6.19E-05	6.19E-05	6.19E-05	6.19E-05	6.19E-05	6.19E-05	6.19E-05	6.19E-05	6.19E-05	6.19E-05	6.19E-05	6.18E-05	6.14E-05	5.68E-05
Np 235	2.00E-01	8.21E-03	3.36E-04	1.38E-05	5.64E-07	9.45E-10	1.59E-12	2.66E-15	7.47E-21	0.00E+00	0.00E+00	0.00E+00	0.00E+00	0.00E+00	0.00E+00	0.00E+00	0.00E+00	0.00E+00
Np 236	8.42E-05	8.42E-05	8.42E-05	8.42E-05	8.42E-05	8.42E-05	8.42E-05	8.42E-05	8.42E-05	8.42E-05	8.42E-05	8.41E-05	8.41E-05	8.39E-05	8.05E-05	5.36E-05	9.08E-07	1.77E-24
Np 237	4.16E+01	4.47E+01	4.55E+01	4.67E+01	4.83E+01	5.19E+01	5.61E+01	6.06E+01	7.00E+01	8.41E+01	1.27E+02	1.64E+02	2.22E+02	3.07E+02	3.76E+02	3.65E+02	2.73E+02	1.49E+01
Np 238	8.63E+07	1.40E+00	1.36E+00	1.33E+00	1.30E+00	1.24E+00	1.18E+00	1.12E+00	1.01E+00	8.76E-01	5.36E-01	3.28E-01	1.23E-01	1.05E-02	0.00E+00	0.00E+00	0.00E+00	0.00E+00
Np 239	4.96E+10	1.95E+03	1.95E+03	1.95E+03	1.95E+03	1.94E+03	1.94E+03	1.94E+03	1.94E+03	1.93E+03	1.91E+03	1.89E+03	1.86E+03	1.77E+03	7.61E+02	1.60E-01	2.38E-07	1.59E-07

Table 28: Zircaloy Cladding - Total Radionuclide Activity (Bq/Initial kg Zr)

220 MWh/kgU, 720 kW/bundle

Nuclide	0.0 Yrs	5.0 Yrs	10.0 Yrs	15.0 Yrs	20.0 Yrs	30.0 Yrs	40.0 Yrs	50.0 Yrs	70.0 Yrs	100.0 Yrs	200.0 Yrs	300.0 Yrs	500.0 Yrs	1.0E3 Yrs	1.0E4 Yrs	1.0E5 Yrs	1.0E6 Yrs	1.0E7 Yrs
Np 240	6.12E+07	7.43E-08	7.43E-08	7.43E-08	7.43E-08	7.43E-08	7.43E-08	7.43E-08	7.43E-08	7.43E-08	7.43E-08	7.43E-08	7.43E-08	7.43E-08	7.43E-08	7.42E-08	7.36E-08	6.82E-08
Np 240m	1.07E+08	6.19E-05	6.19E-05	6.19E-05	6.19E-05	6.19E-05	6.19E-05	6.19E-05	6.19E-05	6.19E-05	6.19E-05	6.19E-05	6.19E-05	6.19E-05	6.19E-05	6.18E-05	6.14E-05	5.68E-05
Pu 236	2.48E+01	7.51E+00	2.23E+00	6.64E-01	1.98E-01	1.75E-02	1.56E-03	1.48E-04	1.24E-05	1.14E-05	1.14E-05	1.14E-05	1.13E-05	1.13E-05	1.09E-05	7.23E-06	1.23E-07	0.00E+00
Pu 237	1.37E+02	1.23E-10	0.00E+00	0.00E+00	0.00E+00	0.00E+00	0.00E+00	0.00E+00	0.00E+00	0.00E+00	0.00E+00	0.00E+00	0.00E+00	0.00E+00	0.00E+00	0.00E+00	0.00E+00	0.00E+00
Pu 238	1.44E+05	1.63E+05	1.57E+05	1.51E+05	1.45E+05	1.34E+05	1.24E+05	1.15E+05	9.79E+04	7.73E+04	3.51E+04	1.60E+04	3.31E+03	6.47E+01	3.05E-19	0.00E+00	0.00E+00	0.00E+00
Pu 239	2.72E+05	2.85E+05	2.85E+05	2.85E+05	2.85E+05	2.85E+05	2.85E+05	2.85E+05	2.85E+05	2.84E+05	2.84E+05	2.83E+05	2.81E+05	2.77E+05	2.14E+05	1.61E+04	3.31E-07	1.59E-07
Pu 240	4.87E+05	4.87E+05	4.87E+05	4.87E+05	4.86E+05	4.86E+05	4.85E+05	4.85E+05	4.84E+05	4.83E+05	4.77E+05	4.72E+05	4.62E+05	4.39E+05	1.69E+05	1.26E+01	6.14E-05	5.68E-05
Pu 241	4.94E+07	3.88E+07	3.04E+07	2.39E+07	1.87E+07	1.15E+07	7.10E+06	4.37E+06	1.66E+06	3.87E+05	3.02E+03	2.54E+01	1.69E+00	1.62E+00	7.80E-01	5.06E-04	0.00E+00	0.00E+00
Pu 242	6.73E+02	6.73E+02	6.73E+02	6.73E+02	6.73E+02	6.73E+02	6.73E+02	6.73E+02	6.73E+02	6.73E+02	6.73E+02	6.72E+02	6.72E+02	6.72E+02	6.60E+02	5.59E+02	1.05E+02	5.85E-06
Pu 243	1.28E+08	2.49E-07	2.49E-07	2.49E-07	2.49E-07	2.49E-07	2.49E-07	2.49E-07	2.49E-07	2.49E-07	2.49E-07	2.49E-07	2.49E-07	2.49E-07	2.49E-07	2.49E-07	2.48E-07	1.59E-07
Pu 244	6.20E-05	6.20E-05	6.20E-05	6.20E-05	6.20E-05	6.20E-05	6.20E-05	6.20E-05	6.20E-05	6.20E-05	6.20E-05	6.20E-05	6.20E-05	6.20E-05	6.20E-05	6.19E-05	6.14E-05	5.69E-05
Pu 246	1.56E-14	2.78E-14	2.77E-14	2.77E-14	2.77E-14	2.77E-14	2.77E-14	2.76E-14	2.76E-14	2.75E-14	2.73E-14	2.71E-14	2.66E-14	2.55E-14	1.20E-14	6.54E-18	0.00E+00	0.00E+00
Am 241	1.33E+04	3.64E+05	6.35E+05	8.46E+05	1.01E+06	1.23E+06	1.35E+06	1.42E+06	1.47E+06	1.44E+06	1.24E+06	1.05E+06	7.64E+05	3.43E+05	9.67E-01	5.33E-04	0.00E+00	0.00E+00
Am 242m	3.12E+02	3.04E+02	2.97E+02	2.90E+02	2.83E+02	2.69E+02	2.56E+02	2.44E+02	2.21E+02	1.91E+02	1.17E+02	7.14E+01	2.67E+01	2.29E+00	1.39E-19	0.00E+00	0.00E+00	0.00E+00
Am 242	2.02E+07	3.03E+02	2.96E+02	2.88E+02	2.81E+02	2.68E+02	2.55E+02	2.43E+02	2.20E+02	1.90E+02	1.16E+02	7.10E+01	2.66E+01	2.27E+00	0.00E+00	0.00E+00	0.00E+00	0.00E+00
Am 243	1.94E+03	1.95E+03	1.95E+03	1.95E+03	1.95E+03	1.94E+03	1.94E+03	1.94E+03	1.94E+03	1.93E+03	1.91E+03	1.89E+03	1.86E+03	1.77E+03	7.61E+02	1.60E-01	2.38E-07	1.59E-07
Am 244	8.64E+05	2.54E-12	1.73E-12	1.17E-12	7.99E-13	3.69E-13	1.71E-13	7.91E-14	1.69E-14	1.68E-15	6.31E-19	0.00E+00	0.00E+00	0.00E+00	0.00E+00	0.00E+00	0.00E+00	0.00E+00
Am 245	5.41E+03	7.30E-11	1.40E-12	2.67E-14	5.12E-16	8.38E-22	0.00E+00	0.00E+00	0.00E+00	0.00E+00	0.00E+00	0.00E+00	0.00E+00	0.00E+00	0.00E+00	0.00E+00	0.00E+00	0.00E+00
Am 246m	2.11E-06	2.78E-14	2.77E-14	2.77E-14	2.77E-14	2.77E-14	2.77E-14	2.76E-14	2.76E-14	2.75E-14	2.73E-14	2.71E-14	2.66E-14	2.55E-14	1.20E-14	6.55E-18	0.00E+00	0.00E+00
Cm 240	1.62E-03	7.04E-24	0.00E+00	0.00E+00	0.00E+00	0.00E+00	0.00E+00	0.00E+00	0.00E+00	0.00E+00	0.00E+00	0.00E+00	0.00E+00	0.00E+00	0.00E+00	0.00E+00	0.00E+00	0.00E+00
Cm 241	4.25E-01	7.35E-18	0.00E+00	0.00E+00	0.00E+00	0.00E+00	0.00E+00	0.00E+00	0.00E+00	0.00E+00	0.00E+00	0.00E+00	0.00E+00	0.00E+00	0.00E+00	0.00E+00	0.00E+00	0.00E+00
Cm 242	4.00E+06	1.97E+03	2.45E+02	2.39E+02	2.33E+02	2.22E+02	2.11E+02	2.01E+02	1.82E+02	1.57E+02	9.61E+01	5.88E+01	2.20E+01	1.88E+00	1.15E-19	0.00E+00	0.00E+00	0.00E+00
Cm 243	5.47E+02	4.86E+02	4.31E+02	3.83E+02	3.40E+02	2.68E+02	2.11E+02	1.66E+02	1.03E+02	5.05E+01	4.67E+00	4.31E-01	3.67E-03	2.47E-08	0.00E+00	0.00E+00	0.00E+00	0.00E+00
Cm 244	7.11E+04	5.88E+04	4.85E+04	4.01E+04	3.31E+04	2.26E+04	1.54E+04	1.05E+04	4.88E+03	1.55E+03	3.37E+01	7.33E-01	3.47E-04	1.69E-12	0.00E+00	0.00E+00	0.00E+00	0.00E+00
Cm 245	1.76E+00	1.76E+00	1.76E+00	1.76E+00	1.76E+00	1.76E+00	1.75E+00	1.75E+00	1.75E+00	1.75E+00	1.73E+00	1.72E+00	1.69E+00	1.62E+00	7.78E-01	5.05E-04	0.00E+00	0.00E+00
Cm 246	3.43E-01	3.43E-01	3.43E-01	3.43E-01	3.43E-01	3.42E-01	3.42E-01	3.41E-01	3.40E-01	3.39E-01	3.34E-01	3.29E-01	3.19E-01	2.97E-01	8.01E-02	1.63E-07	0.00E+00	0.00E+00
Cm 247	2.49E-07	2.49E-07	2.49E-07	2.49E-07	2.49E-07	2.49E-07	2.49E-07	2.49E-07	2.49E-07	2.49E-07	2.49E-07	2.49E-07	2.49E-07	2.49E-07	2.49E-07	2.49E-07	2.48E-07	1.59E-07
Cm 248	2.71E-07	2.71E-07	2.71E-07	2.71E-07	2.71E-07	2.71E-07	2.71E-07	2.71E-07	2.71E-07	2.71E-07	2.71E-07	2.71E-07	2.71E-07	2.70E-07	2.65E-07	2.22E-07	3.70E-08	6.05E-16
Cm 250	1.54E-13	1.54E-13	1.54E-13	1.54E-13	1.54E-13	1.54E-13	1.54E-13	1.54E-13	1.53E-13	1.53E-13	1.52E-13	1.50E-13	1.48E-13	1.42E-13	6.69E-14	3.64E-17	0.00E+00	0.00E+00
Bk 247	5.10E-16	5.09E-16	5.07E-16	5.06E-16	5.05E-16	5.02E-16	5.00E-16	4.97E-16	4.92E-16	4.85E-16	4.61E-16	4.39E-16	3.97E-16	3.09E-16	3.36E-18	0.00E+00	0.00E+00	0.00E+00
Bk 248	3.73E-12	2.54E-12	1.73E-12	1.17E-12	7.98E-13	3.69E-13	1.71E-13	7.91E-14	1.69E-14	1.68E-15	7.53E-19	3.38E-22	0.00E+00	0.00E+00	0.00E+00	0.00E+00	0.00E+00	0.00E+00
Bk 249	2.62E-04	5.04E-06	9.64E-08	1.84E-09	3.53E-11	1.29E-14	4.73E-18	1.73E-21	0.00E+00	0.00E+00	0.00E+00	0.00E+00	0.00E+00	0.00E+00	0.00E+00	0.00E+00	0.00E+00	0.00E+00
Bk 250	3.04E-03	3.03E-13	1.53E-14	1.24E-14	1.23E-14	1.23E-14	1.23E-14	1.23E-14	1.23E-14	1.22E-14	1.21E-14	1.20E-14	1.18E-14	1.13E-14	5.35E-15	2.85E-18	0.00E+00	0.00E+00
Cf 248	2.00E-11	4.68E-13	1.05E-14	2.36E-16	5.30E-18	2.57E-21	1.30E-24	0.00E+00	0.00E+00	0.00E+00	0.00E+00	0.00E+00	0.00E+00	0.00E+00	0.00E+00	0.00E+00	0.00E+00	0.00E+00
Cf 249	2.14E-08	6.61E-07	6.66E-07	6.60E-07	6.53E-07	6.41E-07	6.28E-07	6.16E-07	5.92E-07	5.58E-07	4.58E-07	3.76E-07	2.53E-07	9.43E-08	1.80E-15	0.00E+00	0.00E+00	0.00E+00
Cf 250	6.39E-06	4.97E-06	3.81E-06	2.93E-06	2.25E-06	1.32E-06	7.78E-07	4.58E-07	1.59E-07	3.23E-08	1.61E-10	8.18E-13	1.19E-14	1.13E-14	5.35E-15	2.92E-18	0.00E+00	0.00E+00

Table 28: Zircaloy Cladding - Total Radionuclide Activity (Bq/Initial kg Zr)**220 MWh/kgU, 720 kW/bundle**

Nuclide	0.0 Yrs	5.0 Yrs	10.0 Yrs	15.0 Yrs	20.0 Yrs	30.0 Yrs	40.0 Yrs	50.0 Yrs	70.0 Yrs	100.0 Yrs	200.0 Yrs	300.0 Yrs	500.0 Yrs	1.0E3 Yrs	1.0E4 Yrs	1.0E5 Yrs	1.0E6 Yrs	1.0E7 Yrs
Cf 251	1.75E-08	1.74E-08	1.74E-08	1.73E-08	1.72E-08	1.71E-08	1.70E-08	1.68E-08	1.66E-08	1.62E-08	1.50E-08	1.39E-08	1.19E-08	8.09E-09	7.78E-12	0.00E+00	0.00E+00	0.00E+00
Cf 252	3.55E-06	9.56E-07	2.58E-07	6.96E-08	1.88E-08	1.36E-09	9.93E-11	7.22E-12	3.82E-14	1.47E-17	0.00E+00	0.00E+00	0.00E+00	0.00E+00	0.00E+00	0.00E+00	0.00E+00	0.00E+00
Cf 254	7.51E-09	6.14E-18	0.00E+00	0.00E+00	0.00E+00	0.00E+00	0.00E+00	0.00E+00	0.00E+00	0.00E+00	0.00E+00	0.00E+00	0.00E+00	0.00E+00	0.00E+00	0.00E+00	0.00E+00	0.00E+00
Es 252	1.10E-15	7.53E-17	5.14E-18	3.51E-19	2.40E-20	1.12E-22	5.22E-25	0.00E+00	0.00E+00	0.00E+00	0.00E+00	0.00E+00	0.00E+00	0.00E+00	0.00E+00	0.00E+00	0.00E+00	0.00E+00
Es 254	2.72E-11	2.90E-13	2.94E-15	2.98E-17	3.01E-19	2.95E-23	0.00E+00	0.00E+00	0.00E+00	0.00E+00	0.00E+00	0.00E+00	0.00E+00	0.00E+00	0.00E+00	0.00E+00	0.00E+00	0.00E+00
Es 255	1.80E-10	2.74E-24	0.00E+00	0.00E+00	0.00E+00	0.00E+00	0.00E+00	0.00E+00	0.00E+00	0.00E+00	0.00E+00	0.00E+00	0.00E+00	0.00E+00	0.00E+00	0.00E+00	0.00E+00	0.00E+00
Total¹⁰	2.32E+13	7.74E+10	3.17E+10	1.55E+10	8.52E+09	3.52E+09	2.03E+09	1.45E+09	1.00E+09	7.44E+08	3.94E+08	2.41E+08	1.27E+08	8.64E+07	5.00E+07	2.53E+07	1.36E+07	2.36E+05

¹⁰ Note: the total at time zero represents the total activity of those nuclides presented only. The activity from short-lived nuclides is not included in this total.

Table 29: Total Thermal Power for UO₂ Fuel and Zircaloy Cladding

220 MWh/kgU, 720 kW/bundle

	0.0 Yrs	5.0 Yrs	10.0 Yrs	15.0 Yrs	20.0 Yrs	30.0 Yrs	40.0 Yrs	50.0 Yrs	70.0 Yrs	100.0 Yrs	200.0 Yrs	300.0 Yrs	500.0 Yrs	1.0E3 Yrs	1.0E4 Yrs	1.0E5 Yrs	1.0E6 Yrs	1.0E7 Yrs
UO₂ Fuel (W/Initial kg U)	2.16E+03	4.75E-01	2.68E-01	2.35E-01	2.13E-01	1.79E-01	1.52E-01	1.30E-01	9.86E-02	7.06E-02	4.17E-02	3.52E-02	2.87E-02	1.99E-02	7.09E-03	4.09E-04	1.48E-04	1.01E-04
Zircaloy Cladding (W/Initial kg Zr)	1.66E+01	1.55E-02	7.66E-03	3.88E-03	1.99E-03	5.39E-04	1.53E-04	4.88E-05	1.16E-05	7.00E-06	4.47E-06	3.67E-06	3.01E-06	2.41E-06	1.29E-06	2.03E-07	6.78E-08	5.56E-09

Table 30: UO₂ Fuel - Total Radionuclide Activity (Bq/Initial kg U)

290 MWh/kgU, 720 kW/bundle

Nuclide	0.0 Yrs	5.0 Yrs	10.0 Yrs	15.0 Yrs	20.0 Yrs	30.0 Yrs	40.0 Yrs	50.0 Yrs	70.0 Yrs	100.0 Yrs	200.0 Yrs	300.0 Yrs	500.0 Yrs	1.0E3 Yrs	1.0E4 Yrs	1.0E5 Yrs	1.0E6 Yrs	1.0E7 Yrs
Cd 113m	4.03E+06	3.51E+06	2.75E+06	2.15E+06	1.68E+06	1.03E+06	6.29E+05	3.84E+05	1.44E+05	3.29E+04	2.41E+02	1.77E+00	9.47E-05	2.00E-15	0.00E+00	0.00E+00	0.00E+00	0.00E+00
Cd 115m	2.56E+10	1.18E-02	0.00E+00	0.00E+00	0.00E+00	0.00E+00	0.00E+00	0.00E+00	0.00E+00	0.00E+00	0.00E+00	0.00E+00	0.00E+00	0.00E+00	0.00E+00	0.00E+00	0.00E+00	0.00E+00
Cd 116	8.27E-09	8.27E-09	8.27E-09	8.27E-09	8.27E-09	8.27E-09	8.27E-09	8.27E-09	8.27E-09	8.27E-09	8.27E-09	8.27E-09	8.27E-09	8.27E-09	8.27E-09	8.27E-09	8.27E-09	8.27E-09
In 113m	1.46E+07	2.39E+02	3.99E-03	6.67E-08	1.11E-12	0.00E+00	0.00E+00	0.00E+00	0.00E+00	0.00E+00	0.00E+00	0.00E+00	0.00E+00	0.00E+00	0.00E+00	0.00E+00	0.00E+00	0.00E+00
In 114	7.97E+08	3.40E-03	0.00E+00	0.00E+00	0.00E+00	0.00E+00	0.00E+00	0.00E+00	0.00E+00	0.00E+00	0.00E+00	0.00E+00	0.00E+00	0.00E+00	0.00E+00	0.00E+00	0.00E+00	0.00E+00
In 114m	4.48E+08	3.52E-03	0.00E+00	0.00E+00	0.00E+00	0.00E+00	0.00E+00	0.00E+00	0.00E+00	0.00E+00	0.00E+00	0.00E+00	0.00E+00	0.00E+00	0.00E+00	0.00E+00	0.00E+00	0.00E+00
In 115	3.87E-04	4.01E-04	4.01E-04	4.01E-04	4.01E-04	4.01E-04	4.01E-04	4.01E-04	4.01E-04	4.01E-04	4.01E-04	4.01E-04	4.01E-04	4.01E-04	4.01E-04	4.01E-04	4.01E-04	4.01E-04
In 115m	4.47E+11	1.25E-06	0.00E+00	0.00E+00	0.00E+00	0.00E+00	0.00E+00	0.00E+00	0.00E+00	0.00E+00	0.00E+00	0.00E+00	0.00E+00	0.00E+00	0.00E+00	0.00E+00	0.00E+00	0.00E+00
Sn 113	1.43E+07	2.39E+02	3.99E-03	6.66E-08	1.11E-12	0.00E+00	0.00E+00	0.00E+00	0.00E+00	0.00E+00	0.00E+00	0.00E+00	0.00E+00	0.00E+00	0.00E+00	0.00E+00	0.00E+00	0.00E+00
Sn 119m	5.99E+09	7.96E+07	1.06E+06	1.41E+04	1.87E+02	3.30E-02	5.83E-06	1.03E-09	0.00E+00	0.00E+00	0.00E+00	0.00E+00	0.00E+00	0.00E+00	0.00E+00	0.00E+00	0.00E+00	0.00E+00
Sn 121	3.84E+11	2.77E+08	2.56E+08	2.36E+08	2.18E+08	1.86E+08	1.59E+08	1.36E+08	9.91E+07	6.17E+07	1.27E+07	2.62E+06	1.12E+05	4.15E+01	0.00E+00	0.00E+00	0.00E+00	0.00E+00
Sn 121m	3.86E+08	3.57E+08	3.30E+08	3.04E+08	2.81E+08	2.40E+08	2.05E+08	1.75E+08	1.28E+08	7.96E+07	1.64E+07	3.38E+06	1.44E+05	5.35E+01	0.00E+00	0.00E+00	0.00E+00	0.00E+00
Sn 123	6.18E+10	3.43E+06	1.91E+02	1.06E-02	5.88E-07	0.00E+00	0.00E+00	0.00E+00	0.00E+00	0.00E+00	0.00E+00	0.00E+00	0.00E+00	0.00E+00	0.00E+00	0.00E+00	0.00E+00	0.00E+00
Sn 126	3.98E+06	3.98E+06	3.98E+06	3.98E+06	3.98E+06	3.98E+06	3.98E+06	3.98E+06	3.98E+06	3.98E+06	3.98E+06	3.98E+06	3.97E+06	3.97E+06	3.86E+06	2.94E+06	1.95E+05	3.24E-07
Sb 124	7.53E+09	5.54E+00	4.08E-09	0.00E+00	0.00E+00	0.00E+00	0.00E+00	0.00E+00	0.00E+00	0.00E+00	0.00E+00	0.00E+00	0.00E+00	0.00E+00	0.00E+00	0.00E+00	0.00E+00	0.00E+00
Sb 125	1.74E+11	5.07E+10	1.44E+10	4.11E+09	1.17E+09	9.48E+07	7.68E+06	6.23E+05	4.09E+03	2.18E+00	0.00E+00	0.00E+00	0.00E+00	0.00E+00	0.00E+00	0.00E+00	0.00E+00	0.00E+00
Sb 126m	2.20E+10	3.98E+06	3.98E+06	3.98E+06	3.98E+06	3.98E+06	3.98E+06	3.98E+06	3.98E+06	3.98E+06	3.98E+06	3.98E+06	3.97E+06	3.97E+06	3.86E+06	2.94E+06	1.95E+05	3.24E-07
Sb 126	2.07E+10	5.57E+05	5.57E+05	5.57E+05	5.57E+05	5.57E+05	5.57E+05	5.57E+05	5.57E+05	5.57E+05	5.57E+05	5.57E+05	5.56E+05	5.55E+05	5.41E+05	4.12E+05	2.74E+04	4.53E-08
Te 121	1.90E+06	7.17E+01	3.22E-02	1.44E-05	6.46E-09	0.00E+00	0.00E+00	0.00E+00	0.00E+00	0.00E+00	0.00E+00	0.00E+00	0.00E+00	0.00E+00	0.00E+00	0.00E+00	0.00E+00	0.00E+00
Te 121m	1.59E+05	7.15E+01	3.21E-02	1.44E-05	6.44E-09	1.30E-15	0.00E+00	0.00E+00	0.00E+00	0.00E+00	0.00E+00	0.00E+00	0.00E+00	0.00E+00	0.00E+00	0.00E+00	0.00E+00	0.00E+00
Te 123m	4.10E+07	1.00E+03	2.44E-02	5.96E-07	1.45E-11	0.00E+00	0.00E+00	0.00E+00	0.00E+00	0.00E+00	0.00E+00	0.00E+00	0.00E+00	0.00E+00	0.00E+00	0.00E+00	0.00E+00	0.00E+00
Te 125m	2.91E+10	1.24E+10	3.54E+09	1.01E+09	2.87E+08	2.32E+07	1.88E+06	1.52E+05	1.00E+03	5.33E-01	0.00E+00	0.00E+00	0.00E+00	0.00E+00	0.00E+00	0.00E+00	0.00E+00	0.00E+00
Te 127m	1.19E+11	1.32E+06	1.20E+01	1.08E-04	9.77E-10	0.00E+00	0.00E+00	0.00E+00	0.00E+00	0.00E+00	0.00E+00	0.00E+00	0.00E+00	0.00E+00	0.00E+00	0.00E+00	0.00E+00	0.00E+00
Te 127	3.79E+12	1.30E+06	1.17E+01	1.06E-04	9.56E-10	0.00E+00	0.00E+00	0.00E+00	0.00E+00	0.00E+00	0.00E+00	0.00E+00	0.00E+00	0.00E+00	0.00E+00	0.00E+00	0.00E+00	0.00E+00
Te 128	4.65E-07	4.66E-07	4.66E-07	4.66E-07	4.66E-07	4.66E-07	4.66E-07	4.66E-07	4.66E-07	4.66E-07	4.66E-07	4.66E-07	4.66E-07	4.66E-07	4.66E-07	4.66E-07	4.66E-07	4.66E-07
Te 129m	1.17E+12	5.11E-05	0.00E+00	0.00E+00	0.00E+00	0.00E+00	0.00E+00	0.00E+00	0.00E+00	0.00E+00	0.00E+00	0.00E+00	0.00E+00	0.00E+00	0.00E+00	0.00E+00	0.00E+00	0.00E+00
Te 129	1.16E+13	3.23E-05	0.00E+00	0.00E+00	0.00E+00	0.00E+00	0.00E+00	0.00E+00	0.00E+00	0.00E+00	0.00E+00	0.00E+00	0.00E+00	0.00E+00	0.00E+00	0.00E+00	0.00E+00	0.00E+00
I 125	3.14E+07	1.79E-02	9.92E-12	0.00E+00	0.00E+00	0.00E+00	0.00E+00	0.00E+00	0.00E+00	0.00E+00	0.00E+00	0.00E+00	0.00E+00	0.00E+00	0.00E+00	0.00E+00	0.00E+00	0.00E+00
I 129	3.85E+05	3.93E+05	3.93E+05	3.93E+05	3.93E+05	3.93E+05	3.93E+05	3.93E+05	3.93E+05	3.93E+05	3.93E+05	3.93E+05	3.93E+05	3.93E+05	3.92E+05	3.91E+05	3.76E+05	2.52E+05
Xe 127	4.38E+06	3.44E-09	0.00E+00	0.00E+00	0.00E+00	0.00E+00	0.00E+00	0.00E+00	0.00E+00	0.00E+00	0.00E+00	0.00E+00	0.00E+00	0.00E+00	0.00E+00	0.00E+00	0.00E+00	0.00E+00
Cs 134	1.17E+12	2.18E+11	4.06E+10	7.59E+09	1.42E+09	4.94E+07	1.72E+06	6.00E+04	7.29E+01	3.08E-03	0.00E+00	0.00E+00	0.00E+00	0.00E+00	0.00E+00	0.00E+00	0.00E+00	0.00E+00
Cs 135	1.40E+06	1.43E+06	1.43E+06	1.43E+06	1.43E+06	1.43E+06	1.43E+06	1.43E+06	1.43E+06	1.43E+06	1.43E+06	1.43E+06	1.43E+06	1.43E+06	1.42E+06	1.39E+06	1.06E+06	7.01E+04
Cs 137	1.45E+12	1.29E+12	1.15E+12	1.03E+12	9.16E+11	7.27E+11	5.78E+11	4.59E+11	2.89E+11	1.45E+11	1.45E+10	1.44E+09	1.44E+07	1.42E+02	0.00E+00	0.00E+00	0.00E+00	0.00E+00
Ba 133	4.04E+04	2.91E+04	2.09E+04	1.51E+04	1.08E+04	5.60E+03	2.90E+03	1.50E+03	4.01E+02	5.55E+01	7.61E-02	1.04E-04	1.96E-10	0.00E+00	0.00E+00	0.00E+00	0.00E+00	0.00E+00
Ba 137m	1.41E+12	1.23E+12	1.09E+12	9.73E+11	8.67E+11	6.89E+11	5.47E+11	4.34E+11	2.74E+11	1.37E+11	1.37E+10	1.37E+09	1.36E+07	1.35E+02	0.00E+00	0.00E+00	0.00E+00	0.00E+00

Table 30: UO₂ Fuel - Total Radionuclide Activity (Bq/Initial kg U)

290 MWh/kgU, 720 kW/bundle

Nuclide	0.0 Yrs	5.0 Yrs	10.0 Yrs	15.0 Yrs	20.0 Yrs	30.0 Yrs	40.0 Yrs	50.0 Yrs	70.0 Yrs	100.0 Yrs	200.0 Yrs	300.0 Yrs	500.0 Yrs	1.0E3 Yrs	1.0E4 Yrs	1.0E5 Yrs	1.0E6 Yrs	1.0E7 Yrs
La 137	1.64E+02	1.64E+02	1.64E+02	1.64E+02	1.64E+02	1.64E+02	1.64E+02	1.64E+02	1.64E+02	1.64E+02	1.64E+02	1.64E+02	1.63E+02	1.62E+02	1.46E+02	5.17E+01	1.58E-03	0.00E+00
La 138	3.38E-03	3.38E-03	3.38E-03	3.38E-03	3.38E-03	3.38E-03	3.38E-03	3.38E-03	3.38E-03	3.38E-03	3.38E-03	3.38E-03	3.38E-03	3.38E-03	3.38E-03	3.38E-03	3.38E-03	3.38E-03
Ce 139	8.74E+07	8.85E+03	8.96E-01	9.08E-05	9.19E-09	0.00E+00	0.00E+00	0.00E+00	0.00E+00	0.00E+00	0.00E+00	0.00E+00	0.00E+00	0.00E+00	0.00E+00	0.00E+00	0.00E+00	0.00E+00
Ce 141	5.84E+13	7.17E-04	0.00E+00	0.00E+00	0.00E+00	0.00E+00	0.00E+00	0.00E+00	0.00E+00	0.00E+00	0.00E+00	0.00E+00	0.00E+00	0.00E+00	0.00E+00	0.00E+00	0.00E+00	0.00E+00
Ce 144	2.73E+13	3.21E+11	3.78E+09	4.44E+07	5.22E+05	7.21E+01	9.97E-03	1.38E-06	0.00E+00	0.00E+00	0.00E+00	0.00E+00	0.00E+00	0.00E+00	0.00E+00	0.00E+00	0.00E+00	0.00E+00
Pr 144	2.83E+13	3.21E+11	3.78E+09	4.44E+07	5.22E+05	7.21E+01	9.97E-03	1.38E-06	0.00E+00	0.00E+00	0.00E+00	0.00E+00	0.00E+00	0.00E+00	0.00E+00	0.00E+00	0.00E+00	0.00E+00
Pr 144m	9.28E+11	3.07E+09	3.61E+07	4.24E+05	4.98E+03	6.89E-01	9.52E-05	1.32E-08	0.00E+00	0.00E+00	0.00E+00	0.00E+00	0.00E+00	0.00E+00	0.00E+00	0.00E+00	0.00E+00	0.00E+00
Nd 144	9.74E-03	1.89E-02	1.91E-02	1.91E-02	1.91E-02	1.91E-02	1.91E-02	1.91E-02	1.91E-02	1.91E-02	1.91E-02	1.91E-02	1.91E-02	1.91E-02	1.91E-02	1.91E-02	1.91E-02	1.91E-02
Nd 150	7.53E-07	7.53E-07	7.53E-07	7.53E-07	7.53E-07	7.53E-07	7.53E-07	7.53E-07	7.53E-07	7.53E-07	7.53E-07	7.53E-07	7.53E-07	7.53E-07	7.53E-07	7.53E-07	7.53E-07	7.53E-07
Pm 143	3.03E+00	2.55E-02	2.14E-04	1.81E-06	1.52E-08	1.08E-12	7.64E-17	5.40E-21	0.00E+00	0.00E+00	0.00E+00	0.00E+00	0.00E+00	0.00E+00	0.00E+00	0.00E+00	0.00E+00	0.00E+00
Pm 144	3.60E+01	1.10E+00	3.37E-02	1.03E-03	3.15E-05	2.95E-08	2.75E-11	2.58E-14	2.25E-20	0.00E+00	0.00E+00	0.00E+00	0.00E+00	0.00E+00	0.00E+00	0.00E+00	0.00E+00	0.00E+00
Pm 145	1.84E+04	3.35E+04	2.80E+04	2.30E+04	1.89E+04	1.28E+04	8.65E+03	5.85E+03	2.67E+03	8.25E+02	1.64E+01	3.27E-01	1.30E-04	4.05E-13	0.00E+00	0.00E+00	0.00E+00	0.00E+00
Pm 146	5.66E+05	3.03E+05	1.62E+05	8.64E+04	4.62E+04	1.32E+04	3.76E+03	1.07E+03	8.75E+01	2.04E+00	7.32E-06	2.63E-11	0.00E+00	0.00E+00	0.00E+00	0.00E+00	0.00E+00	0.00E+00
Pm 147	3.28E+12	9.45E+11	2.52E+11	6.72E+10	1.79E+10	1.28E+09	9.09E+07	6.47E+06	3.28E+04	1.18E+01	0.00E+00	0.00E+00	0.00E+00	0.00E+00	0.00E+00	0.00E+00	0.00E+00	0.00E+00
Pm 148	4.85E+12	7.09E-04	0.00E+00	0.00E+00	0.00E+00	0.00E+00	0.00E+00	0.00E+00	0.00E+00	0.00E+00	0.00E+00	0.00E+00	0.00E+00	0.00E+00	0.00E+00	0.00E+00	0.00E+00	0.00E+00
Pm 148m	3.04E+11	1.47E-02	0.00E+00	0.00E+00	0.00E+00	0.00E+00	0.00E+00	0.00E+00	0.00E+00	0.00E+00	0.00E+00	0.00E+00	0.00E+00	0.00E+00	0.00E+00	0.00E+00	0.00E+00	0.00E+00
Sm 145	4.15E+05	1.00E+04	2.42E+02	5.85E+00	1.41E-01	8.24E-05	4.81E-08	2.80E-11	0.00E+00	0.00E+00	0.00E+00	0.00E+00	0.00E+00	0.00E+00	0.00E+00	0.00E+00	0.00E+00	0.00E+00
Sm 146	5.54E-02	6.02E-02	6.28E-02	6.41E-02	6.49E-02	6.55E-02	6.56E-02	6.57E-02	6.57E-02	6.57E-02	6.57E-02	6.57E-02	6.57E-02	6.57E-02	6.57E-02	6.57E-02	6.57E-02	6.53E-02
Sm 147	9.65E+00	7.38E+01	9.10E+01	9.55E+01	9.67E+01	9.72E+01	9.72E+01	9.72E+01	9.72E+01	9.72E+01	9.72E+01	9.72E+01	9.72E+01	9.72E+01	9.72E+01	9.72E+01	9.72E+01	9.72E+01
Sm 148	2.58E-04	2.73E-04	2.73E-04	2.73E-04	2.73E-04	2.73E-04	2.73E-04	2.73E-04	2.73E-04	2.73E-04	2.73E-04	2.73E-04	2.73E-04	2.73E-04	2.73E-04	2.73E-04	2.73E-04	2.73E-04
Sm 151	2.37E+09	2.56E+09	2.46E+09	2.37E+09	2.28E+09	2.11E+09	1.95E+09	1.81E+09	1.55E+09	1.23E+09	5.70E+08	2.64E+08	5.65E+07	1.20E+06	0.00E+00	0.00E+00	0.00E+00	0.00E+00
Eu 148	1.22E-06	9.96E-17	0.00E+00	0.00E+00	0.00E+00	0.00E+00	0.00E+00	0.00E+00	0.00E+00	0.00E+00	0.00E+00	0.00E+00	0.00E+00	0.00E+00	0.00E+00	0.00E+00	0.00E+00	0.00E+00
Eu 149	1.46E+00	1.82E-06	2.26E-12	2.81E-18	0.00E+00	0.00E+00	0.00E+00	0.00E+00	0.00E+00	0.00E+00	0.00E+00	0.00E+00	0.00E+00	0.00E+00	0.00E+00	0.00E+00	0.00E+00	0.00E+00
Eu 150	1.73E+00	1.57E+00	1.43E+00	1.31E+00	1.19E+00	9.85E-01	8.16E-01	6.76E-01	4.64E-01	2.64E-01	4.04E-02	6.17E-03	1.44E-04	1.20E-08	0.00E+00	0.00E+00	0.00E+00	0.00E+00
Eu 152	2.33E+06	1.80E+06	1.40E+06	1.08E+06	8.37E+05	5.01E+05	3.00E+05	1.80E+05	6.46E+04	1.39E+04	8.31E+01	4.96E-01	1.77E-05	0.00E+00	0.00E+00	0.00E+00	0.00E+00	0.00E+00
Eu 154	5.12E+10	3.42E+10	2.28E+10	1.53E+10	1.02E+10	4.56E+09	2.04E+09	9.09E+08	1.81E+08	1.62E+07	5.11E+03	1.61E+00	1.61E-07	0.00E+00	0.00E+00	0.00E+00	0.00E+00	0.00E+00
Eu 155	5.06E+10	2.44E+10	1.18E+10	5.68E+09	2.74E+09	6.37E+08	1.48E+08	3.45E+07	1.86E+06	2.35E+04	1.09E-02	5.03E-09	0.00E+00	0.00E+00	0.00E+00	0.00E+00	0.00E+00	0.00E+00
Gd 148	2.82E-09	2.69E-09	2.57E-09	2.45E-09	2.34E-09	2.13E-09	1.94E-09	1.77E-09	1.47E-09	1.11E-09	4.39E-10	1.73E-10	2.70E-11	2.59E-13	0.00E+00	0.00E+00	0.00E+00	0.00E+00
Gd 150	3.96E-05	3.96E-05	3.96E-05	3.96E-05	3.96E-05	3.96E-05	3.96E-05	3.96E-05	3.96E-05	3.96E-05	3.96E-05	3.96E-05	3.96E-05	3.96E-05	3.95E-05	3.81E-05	2.69E-05	8.24E-07
Gd 151	6.19E+02	2.28E-02	8.39E-07	3.09E-11	1.14E-15	0.00E+00	0.00E+00	0.00E+00	0.00E+00	0.00E+00	0.00E+00	0.00E+00	0.00E+00	0.00E+00	0.00E+00	0.00E+00	0.00E+00	0.00E+00
Gd 152	1.13E-06	1.15E-06	1.17E-06	1.18E-06	1.18E-06	1.20E-06	1.20E-06	1.21E-06	1.21E-06	1.21E-06	1.21E-06	1.21E-06	1.21E-06	1.21E-06	1.21E-06	1.21E-06	1.21E-06	1.21E-06
Gd 153	1.01E+07	5.23E+04	2.70E+02	1.40E+00	7.21E-03	1.92E-07	5.12E-12	0.00E+00	0.00E+00	0.00E+00	0.00E+00	0.00E+00	0.00E+00	0.00E+00	0.00E+00	0.00E+00	0.00E+00	0.00E+00
Tb 157	8.00E+03	7.65E+03	7.29E+03	6.94E+03	6.61E+03	5.99E+03	5.44E+03	4.93E+03	4.06E+03	3.03E+03	1.14E+03	4.29E+02	6.09E+01	4.62E-01	0.00E+00	0.00E+00	0.00E+00	0.00E+00
Tb 158	4.53E+03	4.44E+03	4.36E+03	4.28E+03	4.19E+03	4.04E+03	3.88E+03	3.74E+03	3.46E+03	3.08E+03	2.10E+03	1.43E+03	6.60E+02	9.63E+01	8.52E-14	0.00E+00	0.00E+00	0.00E+00

Table 30: UO₂ Fuel - Total Radionuclide Activity (Bq/Initial kg U)

290 MWh/kgU, 720 kW/bundle

Nuclide	0.0 Yrs	5.0 Yrs	10.0 Yrs	15.0 Yrs	20.0 Yrs	30.0 Yrs	40.0 Yrs	50.0 Yrs	70.0 Yrs	100.0 Yrs	200.0 Yrs	300.0 Yrs	500.0 Yrs	1.0E3 Yrs	1.0E4 Yrs	1.0E5 Yrs	1.0E6 Yrs	1.0E7 Yrs		
Tb 160	2.37E+10	5.90E+02	1.47E-05	0.00E+00	0.00E+00	0.00E+00	0.00E+00	0.00E+00	0.00E+00	0.00E+00	0.00E+00	0.00E+00	0.00E+00	0.00E+00	0.00E+00	0.00E+00	0.00E+00	0.00E+00		
Dy 154	9.84E-10	9.84E-10	9.84E-10	9.84E-10	9.84E-10	9.84E-10	9.84E-10	9.84E-10	9.84E-10	9.84E-10	9.84E-10	9.84E-10	9.84E-10	9.84E-10	9.84E-10	9.82E-10	9.62E-10	7.81E-10	9.76E-11	
Dy 159	1.33E+05	2.07E+01	3.23E-03	5.03E-07	7.84E-11	0.00E+00	0.00E+00	0.00E+00	0.00E+00	0.00E+00	0.00E+00	0.00E+00	0.00E+00	0.00E+00	0.00E+00	0.00E+00	0.00E+00	0.00E+00	0.00E+00	
Ho 163	8.11E+01	8.10E+01	8.10E+01	8.09E+01	8.08E+01	8.07E+01	8.06E+01	8.05E+01	8.02E+01	7.99E+01	7.86E+01	7.75E+01	7.52E+01	6.97E+01	1.78E+01	2.10E-05	0.00E+00	0.00E+00	0.00E+00	
Ho 166m	5.14E+03	5.12E+03	5.11E+03	5.09E+03	5.08E+03	5.05E+03	5.02E+03	4.99E+03	4.93E+03	4.85E+03	4.58E+03	4.32E+03	3.85E+03	2.88E+03	1.59E+01	0.00E+00	0.00E+00	0.00E+00	0.00E+00	
Tm 168	1.60E+04	1.99E-02	2.48E-08	3.08E-14	0.00E+00	0.00E+00	0.00E+00	0.00E+00	0.00E+00	0.00E+00	0.00E+00	0.00E+00	0.00E+00	0.00E+00	0.00E+00	0.00E+00	0.00E+00	0.00E+00	0.00E+00	
Tm 170	1.29E+09	6.87E+04	3.64E+00	1.93E-04	1.03E-08	0.00E+00	0.00E+00	0.00E+00	0.00E+00	0.00E+00	0.00E+00	0.00E+00	0.00E+00	0.00E+00	0.00E+00	0.00E+00	0.00E+00	0.00E+00	0.00E+00	
Tm 171	5.56E+07	9.15E+06	1.50E+06	2.47E+05	4.07E+04	1.10E+03	2.97E+01	8.04E-01	5.88E-04	1.16E-08	0.00E+00	0.00E+00	0.00E+00	0.00E+00	0.00E+00	0.00E+00	0.00E+00	0.00E+00	0.00E+00	
Yb 169	3.69E+03	2.49E-14	0.00E+00	0.00E+00	0.00E+00	0.00E+00	0.00E+00	0.00E+00	0.00E+00	0.00E+00	0.00E+00	0.00E+00	0.00E+00	0.00E+00	0.00E+00	0.00E+00	0.00E+00	0.00E+00	0.00E+00	
Lu 172m	3.20E-02	1.89E-04	2.95E-05	4.63E-06	7.25E-07	1.78E-08	4.37E-10	1.07E-11	0.00E+00	0.00E+00	0.00E+00	0.00E+00	0.00E+00	0.00E+00	0.00E+00	0.00E+00	0.00E+00	0.00E+00	0.00E+00	
Lu 172	6.52E-02	1.89E-04	2.95E-05	4.63E-06	7.32E-07	1.80E-08	4.41E-10	1.08E-11	6.53E-15	9.67E-20	0.00E+00	0.00E+00	0.00E+00	0.00E+00	0.00E+00	0.00E+00	0.00E+00	0.00E+00	0.00E+00	
Lu 173	5.32E+02	4.24E+01	3.38E+00	2.69E-01	2.14E-02	1.36E-04	8.63E-07	5.48E-09	2.21E-13	0.00E+00	0.00E+00	0.00E+00	0.00E+00	0.00E+00	0.00E+00	0.00E+00	0.00E+00	0.00E+00	0.00E+00	
Lu 174m	6.68E+04	8.98E+00	1.21E-03	1.62E-07	2.18E-11	0.00E+00	0.00E+00	0.00E+00	0.00E+00	0.00E+00	0.00E+00	0.00E+00	0.00E+00	0.00E+00	0.00E+00	0.00E+00	0.00E+00	0.00E+00	0.00E+00	
Lu 174	3.68E+04	1.60E+04	5.63E+03	1.97E+03	6.93E+02	8.53E+01	1.05E+01	1.29E+00	1.96E-02	3.67E-05	2.94E-14	0.00E+00	0.00E+00	0.00E+00	0.00E+00	0.00E+00	0.00E+00	0.00E+00	0.00E+00	
Lu 176	1.27E-03	1.27E-03	1.27E-03	1.27E-03	1.27E-03	1.27E-03	1.27E-03	1.27E-03	1.27E-03	1.27E-03	1.27E-03	1.27E-03	1.27E-03	1.27E-03	1.27E-03	1.27E-03	1.27E-03	1.27E-03	1.27E-03	
Lu 177	1.25E+09	1.11E+02	4.16E-02	1.56E-05	5.82E-09	0.00E+00	0.00E+00	0.00E+00	0.00E+00	0.00E+00	0.00E+00	0.00E+00	0.00E+00	0.00E+00	0.00E+00	0.00E+00	0.00E+00	0.00E+00	0.00E+00	
Lu 177m	1.33E+06	4.98E+02	1.86E-01	6.97E-05	2.61E-08	3.65E-15	0.00E+00	0.00E+00	0.00E+00	0.00E+00	0.00E+00	0.00E+00	0.00E+00	0.00E+00	0.00E+00	0.00E+00	0.00E+00	0.00E+00	0.00E+00	
Hf 172	1.20E-03	1.89E-04	2.95E-05	4.63E-06	7.25E-07	1.78E-08	4.37E-10	1.07E-11	6.47E-15	9.57E-20	0.00E+00	0.00E+00	0.00E+00	0.00E+00	0.00E+00	0.00E+00	0.00E+00	0.00E+00	0.00E+00	
Hf 174	4.01E-09	4.01E-09	4.01E-09	4.01E-09	4.01E-09	4.01E-09	4.01E-09	4.01E-09	4.01E-09	4.01E-09	4.01E-09	4.01E-09	4.01E-09	4.01E-09	4.01E-09	4.01E-09	4.01E-09	4.01E-09	4.01E-09	
Hf 175	3.00E+07	4.20E-01	5.87E-09	0.00E+00	0.00E+00	0.00E+00	0.00E+00	0.00E+00	0.00E+00	0.00E+00	0.00E+00	0.00E+00	0.00E+00	0.00E+00	0.00E+00	0.00E+00	0.00E+00	0.00E+00	0.00E+00	
Hf 177m	4.91E+06	3.91E+02	1.46E-01	5.48E-05	2.05E-08	0.00E+00	0.00E+00	0.00E+00	0.00E+00	0.00E+00	0.00E+00	0.00E+00	0.00E+00	0.00E+00	0.00E+00	0.00E+00	0.00E+00	0.00E+00	0.00E+00	
Hf 181	6.53E+08	6.99E-05	0.00E+00	0.00E+00	0.00E+00	0.00E+00	0.00E+00	0.00E+00	0.00E+00	0.00E+00	0.00E+00	0.00E+00	0.00E+00	0.00E+00	0.00E+00	0.00E+00	0.00E+00	0.00E+00	0.00E+00	
Hf 182	1.50E+00	1.50E+00	1.50E+00	1.50E+00	1.50E+00	1.50E+00	1.50E+00	1.50E+00	1.50E+00	1.50E+00	1.50E+00	1.50E+00	1.50E+00	1.50E+00	1.50E+00	1.50E+00	1.50E+00	1.49E+00	1.39E+00	6.88E-01
Ta 179	5.57E+02	8.29E+01	1.23E+01	1.84E+00	2.74E-01	6.07E-03	1.35E-04	2.98E-06	1.47E-09	1.60E-14	0.00E+00	0.00E+00	0.00E+00	0.00E+00	0.00E+00	0.00E+00	0.00E+00	0.00E+00	0.00E+00	
Ta 182	2.55E+08	4.13E+03	1.57E+00	1.50E+00	1.50E+00	1.50E+00	1.50E+00	1.50E+00	1.50E+00	1.50E+00	1.50E+00	1.50E+00	1.50E+00	1.50E+00	1.50E+00	1.50E+00	1.50E+00	1.49E+00	1.39E+00	6.88E-01
W 180	7.86E-11	7.86E-11	7.86E-11	7.86E-11	7.86E-11	7.86E-11	7.86E-11	7.86E-11	7.86E-11	7.86E-11	7.86E-11	7.86E-11	7.86E-11	7.86E-11	7.86E-11	7.86E-11	7.86E-11	7.86E-11	7.86E-11	
W 181	2.98E+07	8.68E+02	2.53E-02	7.35E-07	2.14E-11	0.00E+00	0.00E+00	0.00E+00	0.00E+00	0.00E+00	0.00E+00	0.00E+00	0.00E+00	0.00E+00	0.00E+00	0.00E+00	0.00E+00	0.00E+00	0.00E+00	
W 185	6.18E+08	2.95E+01	1.41E-06	0.00E+00	0.00E+00	0.00E+00	0.00E+00	0.00E+00	0.00E+00	0.00E+00	0.00E+00	0.00E+00	0.00E+00	0.00E+00	0.00E+00	0.00E+00	0.00E+00	0.00E+00	0.00E+00	
W 186	1.91E-10	1.91E-10	1.91E-10	1.91E-10	1.91E-10	1.91E-10	1.91E-10	1.91E-10	1.91E-10	1.91E-10	1.91E-10	1.91E-10	1.91E-10	1.91E-10	1.91E-10	1.91E-10	1.91E-10	1.91E-10	1.91E-10	
W 188	2.21E+07	2.92E-01	3.85E-09	0.00E+00	0.00E+00	0.00E+00	0.00E+00	0.00E+00	0.00E+00	0.00E+00	0.00E+00	0.00E+00	0.00E+00	0.00E+00	0.00E+00	0.00E+00	0.00E+00	0.00E+00	0.00E+00	
Re 183	1.80E+01	2.52E-07	3.53E-15	0.00E+00	0.00E+00	0.00E+00	0.00E+00	0.00E+00	0.00E+00	0.00E+00	0.00E+00	0.00E+00	0.00E+00	0.00E+00	0.00E+00	0.00E+00	0.00E+00	0.00E+00	0.00E+00	
Re 184	1.87E+03	7.60E-02	4.24E-05	2.37E-08	1.32E-11	0.00E+00	0.00E+00	0.00E+00	0.00E+00	0.00E+00	0.00E+00	0.00E+00	0.00E+00	0.00E+00	0.00E+00	0.00E+00	0.00E+00	0.00E+00	0.00E+00	
Re 184m	1.45E+02	8.07E-02	4.50E-05	2.51E-08	1.40E-11	4.37E-18	0.00E+00	0.00E+00	0.00E+00	0.00E+00	0.00E+00	0.00E+00	0.00E+00	0.00E+00	0.00E+00	0.00E+00	0.00E+00	0.00E+00	0.00E+00	
Re 186m	2.91E+00	2.90E+00	2.90E+00	2.90E+00	2.90E+00	2.90E+00	2.90E+00	2.90E+00	2.90E+00	2.90E+00	2.90E+00	2.90E+00	2.90E+00	2.90E+00	2.90E+00	2.81E+00	2.05E+00	9.08E-02	2.57E-15	

Table 30: UO₂ Fuel - Total Radionuclide Activity (Bq/Initial kg U)

290 MWh/kgU, 720 kW/bundle

Nuclide	0.0 Yrs	5.0 Yrs	10.0 Yrs	15.0 Yrs	20.0 Yrs	30.0 Yrs	40.0 Yrs	50.0 Yrs	70.0 Yrs	100.0 Yrs	200.0 Yrs	300.0 Yrs	500.0 Yrs	1.0E3 Yrs	1.0E4 Yrs	1.0E5 Yrs	1.0E6 Yrs	1.0E7 Yrs
Re 186	7.29E+08	2.90E+00	2.90E+00	2.90E+00	2.90E+00	2.90E+00	2.90E+00	2.90E+00	2.90E+00	2.90E+00	2.90E+00	2.90E+00	2.90E+00	2.90E+00	2.81E+00	2.05E+00	9.08E-02	0.00E+00
Re 187	1.58E-01	1.59E-01	1.59E-01	1.59E-01	1.59E-01	1.59E-01	1.59E-01	1.59E-01	1.59E-01	1.59E-01	1.59E-01	1.59E-01	1.59E-01	1.59E-01	1.59E-01	1.59E-01	1.59E-01	1.59E-01
Re 188	3.35E+09	2.95E-01	3.89E-09	0.00E+00	0.00E+00	0.00E+00	0.00E+00	0.00E+00	0.00E+00	0.00E+00	0.00E+00	0.00E+00	0.00E+00	0.00E+00	0.00E+00	0.00E+00	0.00E+00	0.00E+00
Os 185	5.99E+06	8.01E+00	1.07E-05	1.43E-11	0.00E+00	0.00E+00	0.00E+00	0.00E+00	0.00E+00	0.00E+00	0.00E+00	0.00E+00	0.00E+00	0.00E+00	0.00E+00	0.00E+00	0.00E+00	0.00E+00
Os 186	6.53E-07	6.56E-07	6.56E-07	6.56E-07	6.56E-07	6.56E-07	6.56E-07	6.56E-07	6.56E-07	6.56E-07	6.56E-07	6.56E-07	6.56E-07	6.56E-07	6.56E-07	6.56E-07	6.57E-07	6.57E-07
Os 194	2.40E+04	1.35E+04	7.56E+03	4.24E+03	2.38E+03	7.50E+02	2.36E+02	7.44E+01	7.38E+00	2.31E-01	2.21E-06	2.13E-11	0.00E+00	0.00E+00	0.00E+00	0.00E+00	0.00E+00	0.00E+00
Ir 192	4.83E+08	1.72E+01	6.16E-07	0.00E+00	0.00E+00	0.00E+00	0.00E+00	0.00E+00	0.00E+00	0.00E+00	0.00E+00	0.00E+00	0.00E+00	0.00E+00	0.00E+00	0.00E+00	0.00E+00	0.00E+00
Ir 194	2.78E+09	1.35E+04	7.56E+03	4.25E+03	2.38E+03	7.50E+02	2.36E+02	7.44E+01	7.38E+00	2.31E-01	2.21E-06	2.13E-11	0.00E+00	0.00E+00	0.00E+00	0.00E+00	0.00E+00	0.00E+00
Pt 190	2.05E-06	2.05E-06	2.05E-06	2.05E-06	2.05E-06	2.05E-06	2.05E-06	2.05E-06	2.05E-06	2.05E-06	2.05E-06	2.05E-06	2.05E-06	2.05E-06	2.05E-06	2.05E-06	2.05E-06	2.05E-06
Pt 193	5.33E+05	5.01E+05	4.67E+05	4.36E+05	4.07E+05	3.54E+05	3.08E+05	2.68E+05	2.03E+05	1.34E+05	3.35E+04	8.38E+03	5.24E+02	5.11E-01	0.00E+00	0.00E+00	0.00E+00	0.00E+00
Au 194	2.28E-04	9.26E-06	9.19E-06	9.12E-06	9.05E-06	8.91E-06	8.77E-06	8.63E-06	8.37E-06	7.98E-06	6.83E-06	5.84E-06	4.28E-06	1.96E-06	1.55E-12	0.00E+00	0.00E+00	0.00E+00
Au 195	5.85E+01	6.50E-02	7.22E-05	8.02E-08	8.90E-11	1.10E-16	0.00E+00	0.00E+00	0.00E+00	0.00E+00	0.00E+00	0.00E+00	0.00E+00	0.00E+00	0.00E+00	0.00E+00	0.00E+00	0.00E+00
Hg 194	9.33E-06	9.26E-06	9.19E-06	9.12E-06	9.05E-06	8.91E-06	8.77E-06	8.63E-06	8.37E-06	7.98E-06	6.83E-06	5.84E-06	4.28E-06	1.96E-06	1.55E-12	0.00E+00	0.00E+00	0.00E+00
Hg 203	2.30E+08	3.65E-04	0.00E+00	0.00E+00	0.00E+00	0.00E+00	0.00E+00	0.00E+00	0.00E+00	0.00E+00	0.00E+00	0.00E+00	0.00E+00	0.00E+00	0.00E+00	0.00E+00	0.00E+00	0.00E+00
Hg 206	8.43E-01	1.61E-05	1.38E-05	1.18E-05	1.01E-05	7.46E-06	5.59E-06	4.31E-06	2.96E-06	2.88E-06	1.07E-05	3.31E-05	9.17E-05	3.60E-04	1.46E-02	1.30E-01	2.36E-01	2.32E-01
Tl 202	3.44E+05	2.24E-05	2.23E-05	2.23E-05	2.23E-05	2.23E-05	2.23E-05	2.23E-05	2.23E-05	2.23E-05	2.23E-05	2.23E-05	2.22E-05	2.21E-05	1.96E-05	5.97E-06	4.12E-11	0.00E+00
Tl 204	2.11E+08	8.43E+07	3.37E+07	1.35E+07	5.39E+06	8.63E+05	1.38E+05	2.21E+04	5.66E+02	2.32E+00	2.55E-08	0.00E+00	0.00E+00	0.00E+00	0.00E+00	0.00E+00	0.00E+00	0.00E+00
Tl 206	4.69E+07	1.31E+00	1.31E+00	1.31E+00	1.31E+00	1.31E+00	1.31E+00	1.31E+00	1.31E+00	1.31E+00	1.31E+00	1.31E+00	1.32E+00	1.34E+00	2.33E+00	1.04E+01	1.77E+01	1.65E+01
Tl 207	9.43E+03	1.28E+05	2.30E+05	3.17E+05	3.91E+05	5.09E+05	5.94E+05	6.56E+05	7.34E+05	7.87E+05	8.18E+05	8.18E+05	8.15E+05	8.07E+05	6.88E+05	3.29E+05	3.06E+05	3.03E+05
Tl 208	2.10E+07	1.20E+08	1.31E+08	1.27E+08	1.21E+08	1.10E+08	9.92E+07	8.97E+07	7.33E+07	5.42E+07	1.98E+07	7.25E+06	9.70E+05	7.03E+03	6.95E+02	7.04E+02	7.99E+02	1.62E+03
Tl 209	7.10E+02	1.07E+02	1.42E+02	1.78E+02	2.14E+02	2.85E+02	3.57E+02	4.28E+02	5.70E+02	7.83E+02	1.49E+03	2.19E+03	3.57E+03	6.91E+03	4.88E+04	1.37E+05	1.92E+05	9.81E+03
Tl 210	8.44E-05	2.49E-04	6.25E-04	1.19E-03	1.94E-03	4.01E-03	6.86E-03	1.05E-02	2.01E-02	4.05E-02	1.62E-01	3.65E-01	1.01E+00	3.98E+00	1.61E+02	1.44E+03	2.61E+03	2.56E+03
Pb 202	2.24E-05	2.24E-05	2.23E-05	2.23E-05	2.23E-05	2.23E-05	2.23E-05	2.23E-05	2.23E-05	2.23E-05	2.23E-05	2.23E-05	2.22E-05	2.21E-05	1.96E-05	5.97E-06	4.12E-11	0.00E+00
Pb 204	5.99E-09	9.32E-09	1.07E-08	1.12E-08	1.14E-08	1.15E-08	1.15E-08	1.15E-08	1.15E-08	1.15E-08	1.15E-08	1.15E-08	1.15E-08	1.15E-08	1.15E-08	1.15E-08	1.15E-08	1.15E-08
Pb 205	1.20E-01	1.20E-01	1.20E-01	1.20E-01	1.20E-01	1.20E-01	1.20E-01	1.20E-01	1.20E-01	1.20E-01	1.20E-01	1.20E-01	1.20E-01	1.20E-01	1.20E-01	1.19E-01	1.15E-01	8.01E-02
Pb 209	2.90E+05	4.85E+03	6.47E+03	8.10E+03	9.72E+03	1.30E+04	1.62E+04	1.95E+04	2.59E+04	3.56E+04	6.77E+04	9.95E+04	1.62E+05	3.14E+05	2.22E+06	6.24E+06	8.73E+06	4.46E+05
Pb 210	8.58E+02	8.46E+02	7.24E+02	6.20E+02	5.32E+02	3.93E+02	2.94E+02	2.27E+02	1.56E+02	1.52E+02	5.64E+02	1.74E+03	4.83E+03	1.90E+04	7.67E+05	6.84E+06	1.24E+07	1.22E+07
Pb 211	7.99E+03	1.28E+05	2.30E+05	3.18E+05	3.92E+05	5.10E+05	5.96E+05	6.58E+05	7.36E+05	7.89E+05	8.21E+05	8.21E+05	8.17E+05	8.10E+05	6.90E+05	3.30E+05	3.07E+05	3.04E+05
Pb 212	5.79E+07	3.35E+08	3.64E+08	3.53E+08	3.37E+08	3.05E+08	2.76E+08	2.49E+08	2.04E+08	1.51E+08	5.52E+07	2.02E+07	2.70E+06	1.96E+04	1.93E+03	1.96E+03	2.22E+03	4.51E+03
Pb 214	2.68E-01	1.19E+00	2.97E+00	5.65E+00	9.23E+00	1.91E+01	3.27E+01	4.99E+01	9.56E+01	1.93E+02	7.70E+02	1.74E+03	4.83E+03	1.90E+04	7.67E+05	6.84E+06	1.24E+07	1.22E+07
Bi 207	1.82E+01	1.63E+01	1.46E+01	1.31E+01	1.17E+01	9.41E+00	7.56E+00	6.07E+00	3.91E+00	2.02E+00	2.25E-01	2.50E-02	3.08E-04	5.22E-09	0.00E+00	0.00E+00	0.00E+00	0.00E+00
Bi 208	2.44E+00	2.44E+00	2.44E+00	2.44E+00	2.44E+00	2.44E+00	2.44E+00	2.44E+00	2.44E+00	2.44E+00	2.44E+00	2.44E+00	2.44E+00	2.43E+00	2.39E+00	2.02E+00	3.71E-01	1.61E-08
Bi 209	4.13E-09	4.13E-09	4.13E-09	4.13E-09	4.13E-09	4.13E-09	4.13E-09	4.13E-09	4.13E-09	4.13E-09	4.13E-09	4.13E-09	4.13E-09	4.14E-09	4.59E-09	2.04E-08	3.12E-07	1.25E-06
Bi 210m	1.31E+00	1.31E+00	1.31E+00	1.31E+00	1.31E+00	1.31E+00	1.31E+00	1.31E+00	1.31E+00	1.31E+00	1.31E+00	1.31E+00	1.31E+00	1.31E+00	1.31E+00	1.28E+00	1.04E+00	1.34E-01
Bi 210	1.47E+07	8.47E+02	7.25E+02	6.21E+02	5.32E+02	3.93E+02	2.95E+02	2.27E+02	1.56E+02	1.52E+02	5.64E+02	1.74E+03	4.83E+03	1.90E+04	7.67E+05	6.84E+06	1.24E+07	1.22E+07

Table 30: UO₂ Fuel - Total Radionuclide Activity (Bq/Initial kg U)

290 MWh/kgU, 720 kW/bundle

Nuclide	0.0 Yrs	5.0 Yrs	10.0 Yrs	15.0 Yrs	20.0 Yrs	30.0 Yrs	40.0 Yrs	50.0 Yrs	70.0 Yrs	100.0 Yrs	200.0 Yrs	300.0 Yrs	500.0 Yrs	1.0E3 Yrs	1.0E4 Yrs	1.0E5 Yrs	1.0E6 Yrs	1.0E7 Yrs
Bi 211	9.38E+03	1.28E+05	2.30E+05	3.18E+05	3.92E+05	5.10E+05	5.96E+05	6.58E+05	7.36E+05	7.89E+05	8.21E+05	8.21E+05	8.17E+05	8.10E+05	6.90E+05	3.30E+05	3.07E+05	3.04E+05
Bi 212	5.84E+07	3.35E+08	3.64E+08	3.53E+08	3.37E+08	3.05E+08	2.76E+08	2.49E+08	2.04E+08	1.51E+08	5.52E+07	2.02E+07	2.70E+06	1.96E+04	1.93E+03	1.96E+03	2.22E+03	4.51E+03
Bi 213	3.23E+04	4.85E+03	6.47E+03	8.10E+03	9.72E+03	1.30E+04	1.62E+04	1.95E+04	2.59E+04	3.56E+04	6.77E+04	9.95E+04	1.62E+05	3.14E+05	2.22E+06	6.24E+06	8.73E+06	4.46E+05
Bi 214	2.68E-01	1.19E+00	2.98E+00	5.66E+00	9.24E+00	1.91E+01	3.27E+01	4.99E+01	9.57E+01	1.93E+02	7.70E+02	1.74E+03	4.83E+03	1.90E+04	7.67E+05	6.84E+06	1.24E+07	1.22E+07
Po 208	1.08E-02	3.26E-03	9.87E-04	2.98E-04	9.03E-05	8.26E-06	7.55E-07	6.90E-08	5.77E-10	4.41E-13	0.00E+00	0.00E+00	0.00E+00	0.00E+00	0.00E+00	0.00E+00	0.00E+00	0.00E+00
Po 209	4.31E-01	4.17E-01	4.03E-01	3.89E-01	3.76E-01	3.52E-01	3.28E-01	3.07E-01	2.68E-01	2.18E-01	1.11E-01	5.61E-02	1.44E-02	4.82E-04	0.00E+00	0.00E+00	0.00E+00	0.00E+00
Po 210	1.10E+07	2.08E+03	7.25E+02	6.21E+02	5.32E+02	3.93E+02	2.95E+02	2.27E+02	1.56E+02	1.52E+02	5.64E+02	1.74E+03	4.83E+03	1.90E+04	7.67E+05	6.84E+06	1.24E+07	1.22E+07
Po 211	6.73E+02	3.53E+02	6.36E+02	8.77E+02	1.08E+03	1.41E+03	1.64E+03	1.82E+03	2.03E+03	2.18E+03	2.26E+03	2.26E+03	2.26E+03	2.23E+03	1.90E+03	9.11E+02	8.47E+02	8.39E+02
Po 212	3.74E+07	2.14E+08	2.33E+08	2.26E+08	2.16E+08	1.95E+08	1.77E+08	1.60E+08	1.31E+08	9.66E+07	3.53E+07	1.29E+07	1.73E+06	1.25E+04	1.24E+03	1.26E+03	1.42E+03	2.89E+03
Po 213	3.15E+04	4.74E+03	6.33E+03	7.92E+03	9.51E+03	1.27E+04	1.59E+04	1.90E+04	2.54E+04	3.48E+04	6.62E+04	9.73E+04	1.59E+05	3.07E+05	2.17E+06	6.11E+06	8.54E+06	4.36E+05
Po 214	3.22E+04	1.19E+00	2.97E+00	5.65E+00	9.23E+00	1.91E+01	3.27E+01	4.99E+01	9.56E+01	1.93E+02	7.70E+02	1.74E+03	4.83E+03	1.90E+04	7.67E+05	6.84E+06	1.24E+07	1.22E+07
Po 215	7.94E+03	1.28E+05	2.30E+05	3.18E+05	3.92E+05	5.10E+05	5.96E+05	6.58E+05	7.36E+05	7.89E+05	8.21E+05	8.21E+05	8.17E+05	8.10E+05	6.90E+05	3.30E+05	3.07E+05	3.04E+05
Po 216	5.81E+07	3.35E+08	3.64E+08	3.53E+08	3.37E+08	3.05E+08	2.76E+08	2.49E+08	2.04E+08	1.51E+08	5.52E+07	2.02E+07	2.70E+06	1.96E+04	1.93E+03	1.96E+03	2.22E+03	4.51E+03
Po 218	2.68E-01	1.19E+00	2.98E+00	5.66E+00	9.24E+00	1.91E+01	3.27E+01	4.99E+01	9.57E+01	1.93E+02	7.70E+02	1.74E+03	4.83E+03	1.90E+04	7.67E+05	6.84E+06	1.24E+07	1.22E+07
At 217	3.23E+04	4.85E+03	6.47E+03	8.10E+03	9.72E+03	1.30E+04	1.62E+04	1.95E+04	2.59E+04	3.56E+04	6.77E+04	9.95E+04	1.62E+05	3.14E+05	2.22E+06	6.24E+06	8.73E+06	4.46E+05
At 218	5.37E-05	2.37E-04	5.95E-04	1.13E-03	1.85E-03	3.82E-03	6.53E-03	9.98E-03	1.91E-02	3.86E-02	1.54E-01	3.48E-01	9.66E-01	3.79E+00	1.53E+02	1.37E+03	2.49E+03	2.44E+03
Rn 217	2.26E+00	3.39E-01	4.53E-01	5.67E-01	6.81E-01	9.08E-01	1.14E+00	1.36E+00	1.82E+00	2.49E+00	4.74E+00	6.96E+00	1.14E+01	2.20E+01	1.55E+02	4.37E+02	6.11E+02	3.12E+01
Rn 218	3.22E+04	2.37E-07	5.95E-07	1.13E-06	1.85E-06	3.82E-06	6.53E-06	9.98E-06	1.91E-05	3.86E-05	1.54E-04	3.48E-04	9.66E-04	3.79E-03	1.53E-01	1.37E+00	2.49E+00	2.44E+00
Rn 219	7.94E+03	1.28E+05	2.30E+05	3.18E+05	3.92E+05	5.10E+05	5.96E+05	6.58E+05	7.36E+05	7.89E+05	8.21E+05	8.21E+05	8.17E+05	8.10E+05	6.90E+05	3.30E+05	3.07E+05	3.04E+05
Rn 220	5.81E+07	3.35E+08	3.64E+08	3.53E+08	3.37E+08	3.05E+08	2.76E+08	2.49E+08	2.04E+08	1.51E+08	5.52E+07	2.02E+07	2.70E+06	1.96E+04	1.93E+03	1.96E+03	2.22E+03	4.51E+03
Rn 222	2.68E-01	1.19E+00	2.98E+00	5.66E+00	9.24E+00	1.91E+01	3.27E+01	4.99E+01	9.57E+01	1.93E+02	7.70E+02	1.74E+03	4.83E+03	1.90E+04	7.67E+05	6.84E+06	1.24E+07	1.22E+07
Fr 221	3.23E+04	4.85E+03	6.47E+03	8.10E+03	9.72E+03	1.30E+04	1.62E+04	1.95E+04	2.59E+04	3.56E+04	6.77E+04	9.95E+04	1.62E+05	3.14E+05	2.22E+06	6.24E+06	8.73E+06	4.46E+05
Fr 223	1.06E+02	1.76E+03	3.18E+03	4.39E+03	5.41E+03	7.04E+03	8.22E+03	9.08E+03	1.02E+04	1.09E+04	1.13E+04	1.13E+04	1.13E+04	1.12E+04	9.52E+03	4.55E+03	4.23E+03	4.20E+03
Ra 223	7.94E+03	1.28E+05	2.30E+05	3.18E+05	3.92E+05	5.10E+05	5.96E+05	6.58E+05	7.36E+05	7.89E+05	8.21E+05	8.21E+05	8.17E+05	8.10E+05	6.90E+05	3.30E+05	3.07E+05	3.04E+05
Ra 224	5.81E+07	3.35E+08	3.64E+08	3.53E+08	3.37E+08	3.05E+08	2.76E+08	2.49E+08	2.04E+08	1.51E+08	5.52E+07	2.02E+07	2.70E+06	1.96E+04	1.93E+03	1.96E+03	2.22E+03	4.51E+03
Ra 225	3.96E+04	4.85E+03	6.47E+03	8.10E+03	9.72E+03	1.30E+04	1.62E+04	1.95E+04	2.59E+04	3.56E+04	6.77E+04	9.95E+04	1.62E+05	3.14E+05	2.22E+06	6.24E+06	8.73E+06	4.46E+05
Ra 226	2.81E-01	1.19E+00	2.98E+00	5.66E+00	9.24E+00	1.91E+01	3.27E+01	4.99E+01	9.57E+01	1.93E+02	7.70E+02	1.74E+03	4.83E+03	1.90E+04	7.67E+05	6.84E+06	1.24E+07	1.22E+07
Ra 228	2.68E+02	1.02E+03	1.43E+03	1.66E+03	1.78E+03	1.89E+03	1.92E+03	1.93E+03	1.93E+03	1.93E+03	1.93E+03	1.93E+03	1.93E+03	1.93E+03	1.93E+03	1.96E+03	2.22E+03	4.51E+03
Ac 225	3.22E+04	4.85E+03	6.47E+03	8.10E+03	9.72E+03	1.30E+04	1.62E+04	1.95E+04	2.59E+04	3.56E+04	6.77E+04	9.95E+04	1.62E+05	3.14E+05	2.22E+06	6.24E+06	8.73E+06	4.46E+05
Ac 227	7.70E+03	1.28E+05	2.30E+05	3.18E+05	3.92E+05	5.10E+05	5.96E+05	6.58E+05	7.36E+05	7.89E+05	8.21E+05	8.21E+05	8.17E+05	8.10E+05	6.90E+05	3.30E+05	3.07E+05	3.04E+05
Ac 228	1.02E+06	1.02E+03	1.43E+03	1.66E+03	1.78E+03	1.89E+03	1.92E+03	1.93E+03	1.93E+03	1.93E+03	1.93E+03	1.93E+03	1.93E+03	1.93E+03	1.93E+03	1.96E+03	2.22E+03	4.51E+03
Th 227	7.98E+03	1.26E+05	2.27E+05	3.13E+05	3.87E+05	5.03E+05	5.87E+05	6.49E+05	7.26E+05	7.79E+05	8.09E+05	8.09E+05	8.06E+05	7.98E+05	6.80E+05	3.25E+05	3.03E+05	3.00E+05
Th 228	5.94E+07	3.35E+08	3.64E+08	3.53E+08	3.37E+08	3.05E+08	2.76E+08	2.49E+08	2.04E+08	1.51E+08	5.52E+07	2.02E+07	2.70E+06	1.96E+04	1.93E+03	1.96E+03	2.22E+03	4.51E+03
Th 229	3.23E+03	4.85E+03	6.47E+03	8.10E+03	9.72E+03	1.30E+04	1.62E+04	1.95E+04	2.59E+04	3.56E+04	6.77E+04	9.95E+04	1.62E+05	3.14E+05	2.22E+06	6.24E+06	8.73E+06	4.46E+05
Th 230	2.14E+02	6.22E+02	1.03E+03	1.45E+03	1.87E+03	2.72E+03	3.59E+03	4.46E+03	6.25E+03	9.01E+03	1.86E+04	2.86E+04	4.90E+04	1.00E+05	9.86E+05	6.84E+06	1.24E+07	1.22E+07
Th 231	2.07E+09	8.52E+04	8.52E+04	8.52E+04	8.53E+04	8.53E+04	8.54E+04	8.54E+04	8.56E+04	8.58E+04	8.64E+04	8.70E+04	8.83E+04	9.14E+04	1.40E+05	2.95E+05	3.07E+05	3.04E+05

Table 30: UO₂ Fuel - Total Radionuclide Activity (Bq/Initial kg U)

290 MWh/kgU, 720 kW/bundle

Nuclide	0.0 Yrs	5.0 Yrs	10.0 Yrs	15.0 Yrs	20.0 Yrs	30.0 Yrs	40.0 Yrs	50.0 Yrs	70.0 Yrs	100.0 Yrs	200.0 Yrs	300.0 Yrs	500.0 Yrs	1.0E3 Yrs	1.0E4 Yrs	1.0E5 Yrs	1.0E6 Yrs	1.0E7 Yrs
Am 246m	3.21E-01	1.02E-08	1.02E-08	1.02E-08	1.02E-08	1.02E-08	1.02E-08	1.02E-08	1.02E-08	1.01E-08	1.01E-08	9.97E-09	9.81E-09	9.41E-09	4.44E-09	2.41E-12	0.00E+00	0.00E+00
Cm 240	1.03E+02	4.48E-19	0.00E+00	0.00E+00	0.00E+00	0.00E+00	0.00E+00	0.00E+00	0.00E+00	0.00E+00	0.00E+00	0.00E+00	0.00E+00	0.00E+00	0.00E+00	0.00E+00	0.00E+00	0.00E+00
Cm 241	2.48E+04	4.28E-13	0.00E+00	0.00E+00	0.00E+00	0.00E+00	0.00E+00	0.00E+00	0.00E+00	0.00E+00	0.00E+00	0.00E+00	0.00E+00	0.00E+00	0.00E+00	0.00E+00	0.00E+00	0.00E+00
Cm 242	2.01E+11	9.56E+07	9.40E+06	9.14E+06	8.92E+06	8.49E+06	8.08E+06	7.69E+06	6.97E+06	6.02E+06	3.68E+06	2.25E+06	8.42E+05	7.20E+04	4.39E-15	0.00E+00	0.00E+00	0.00E+00
Cm 243	3.58E+07	3.18E+07	2.82E+07	2.51E+07	2.22E+07	1.75E+07	1.38E+07	1.09E+07	6.76E+06	3.31E+06	3.06E+05	2.82E+04	2.41E+02	1.62E-03	0.00E+00	0.00E+00	0.00E+00	0.00E+00
Cm 244	5.75E+09	4.75E+09	3.92E+09	3.24E+09	2.68E+09	1.82E+09	1.24E+09	8.49E+08	3.95E+08	1.25E+08	2.72E+06	5.92E+04	2.80E+01	1.37E-07	0.00E+00	0.00E+00	0.00E+00	0.00E+00
Cm 245	1.70E+05	1.70E+05	1.70E+05	1.70E+05	1.70E+05	1.70E+05	1.69E+05	1.69E+05	1.69E+05	1.69E+05	1.67E+05	1.66E+05	1.63E+05	1.57E+05	7.52E+04	4.88E+01	0.00E+00	0.00E+00
Cm 246	4.66E+04	4.66E+04	4.66E+04	4.65E+04	4.65E+04	4.64E+04	4.64E+04	4.63E+04	4.62E+04	4.60E+04	4.53E+04	4.47E+04	4.34E+04	4.03E+04	1.09E+04	2.21E-02	0.00E+00	0.00E+00
Cm 247	4.62E-02	4.62E-02	4.62E-02	4.62E-02	4.62E-02	4.62E-02	4.62E-02	4.62E-02	4.62E-02	4.62E-02	4.62E-02	4.62E-02	4.62E-02	4.62E-02	4.62E-02	4.60E-02	4.42E-02	2.96E-02
Cm 248	6.93E-02	6.93E-02	6.93E-02	6.93E-02	6.93E-02	6.93E-02	6.93E-02	6.93E-02	6.93E-02	6.93E-02	6.93E-02	6.93E-02	6.92E-02	6.92E-02	6.79E-02	5.68E-02	9.45E-03	1.55E-10
Cm 250	5.64E-08	5.68E-08	5.68E-08	5.67E-08	5.67E-08	5.67E-08	5.66E-08	5.66E-08	5.65E-08	5.63E-08	5.59E-08	5.54E-08	5.45E-08	5.23E-08	2.46E-08	1.34E-11	0.00E+00	0.00E+00
Bk 247	2.36E-10	2.35E-10	2.35E-10	2.34E-10	2.33E-10	2.32E-10	2.31E-10	2.30E-10	2.28E-10	2.24E-10	2.13E-10	2.03E-10	1.83E-10	1.43E-10	1.55E-12	0.00E+00	0.00E+00	0.00E+00
Bk 248	1.61E-06	1.09E-06	7.43E-07	5.06E-07	3.44E-07	1.59E-07	7.36E-08	3.40E-08	7.29E-09	7.22E-10	3.24E-13	1.46E-16	2.42E-23	0.00E+00	0.00E+00	0.00E+00	0.00E+00	0.00E+00
Bk 249	8.22E+01	1.58E+00	3.02E-02	5.78E-04	1.11E-05	4.05E-09	1.48E-12	5.43E-16	0.00E+00	0.00E+00	0.00E+00	0.00E+00	0.00E+00	0.00E+00	0.00E+00	0.00E+00	0.00E+00	0.00E+00
Bk 250	9.66E+02	2.82E-07	7.35E-09	4.57E-09	4.54E-09	4.54E-09	4.53E-09	4.53E-09	4.52E-09	4.51E-09	4.47E-09	4.43E-09	4.36E-09	4.18E-09	1.97E-09	1.07E-12	0.00E+00	0.00E+00
Cf 248	9.78E-06	2.26E-07	5.08E-09	1.14E-10	2.56E-12	1.29E-15	6.34E-19	2.64E-22	0.00E+00	0.00E+00	0.00E+00	0.00E+00	0.00E+00	0.00E+00	0.00E+00	0.00E+00	0.00E+00	0.00E+00
Cf 249	8.08E-03	2.08E-01	2.10E-01	2.08E-01	2.06E-01	2.02E-01	1.98E-01	1.94E-01	1.87E-01	1.76E-01	1.45E-01	1.19E-01	7.99E-02	2.98E-02	5.68E-10	0.00E+00	0.00E+00	0.00E+00
Cf 250	2.44E+00	1.89E+00	1.45E+00	1.12E+00	8.56E-01	5.04E-01	2.96E-01	1.75E-01	6.05E-02	1.23E-02	6.16E-05	3.12E-07	4.37E-09	4.18E-09	1.97E-09	1.07E-12	0.00E+00	0.00E+00
Cf 251	7.38E-03	7.35E-03	7.32E-03	7.29E-03	7.26E-03	7.21E-03	7.15E-03	7.10E-03	6.99E-03	6.83E-03	6.32E-03	5.85E-03	5.02E-03	3.41E-03	3.28E-06	0.00E+00	0.00E+00	0.00E+00
Cf 252	2.07E+00	5.59E-01	1.51E-01	4.07E-02	1.10E-02	7.98E-04	5.80E-05	4.22E-06	2.23E-08	8.60E-12	0.00E+00	0.00E+00	0.00E+00	0.00E+00	0.00E+00	0.00E+00	0.00E+00	0.00E+00
Cf 254	6.83E-03	5.58E-12	4.24E-21	0.00E+00	0.00E+00	0.00E+00	0.00E+00	0.00E+00	0.00E+00	0.00E+00	0.00E+00	0.00E+00	0.00E+00	0.00E+00	0.00E+00	0.00E+00	0.00E+00	0.00E+00
Es 252	1.05E-09	7.15E-11	4.88E-12	3.34E-13	2.28E-14	1.06E-16	4.95E-19	2.31E-21	0.00E+00	0.00E+00	0.00E+00	0.00E+00	0.00E+00	0.00E+00	0.00E+00	0.00E+00	0.00E+00	0.00E+00
Es 254	2.61E-05	2.77E-07	2.81E-09	2.84E-11	2.88E-13	2.83E-17	2.87E-21	0.00E+00	0.00E+00	0.00E+00	0.00E+00	0.00E+00	0.00E+00	0.00E+00	0.00E+00	0.00E+00	0.00E+00	0.00E+00
Es 255	1.86E-04	2.86E-18	0.00E+00	0.00E+00	0.00E+00	0.00E+00	0.00E+00	0.00E+00	0.00E+00	0.00E+00	0.00E+00	0.00E+00	0.00E+00	0.00E+00	0.00E+00	0.00E+00	0.00E+00	0.00E+00
Total¹¹	1.66E+15	8.27E+12	5.05E+12	4.15E+12	3.56E+12	2.71E+12	2.09E+12	1.63E+12	1.01E+12	5.21E+11	1.03E+11	5.73E+10	4.34E+10	2.97E+10	1.02E+10	7.90E+08	3.21E+08	1.85E+08

¹¹ Note: The total at time zero represents the total activity of those nuclides presented only. The activity from short-lived nuclides is not included in this total.

Table 31: Zircaloy Cladding - Total Radionuclide Activity (Bq/Initial kg Zr)

290 MWh/kgU, 720 kW/bundle

Nuclide	0.0 Yrs	5.0 Yrs	10.0 Yrs	15.0 Yrs	20.0 Yrs	30.0 Yrs	40.0 Yrs	50.0 Yrs	70.0 Yrs	100.0 Yrs	200.0 Yrs	300.0 Yrs	500.0 Yrs	1.0E3 Yrs	1.0E4 Yrs	1.0E5 Yrs	1.0E6 Yrs	1.0E7 Yrs
Mn 53	4.24E+00	4.24E+00	4.24E+00	4.24E+00	4.24E+00	4.24E+00	4.24E+00	4.24E+00	4.24E+00	4.24E+00	4.24E+00	4.24E+00	4.24E+00	4.24E+00	4.24E+00	4.17E+00	3.52E+00	6.52E-01
Mn 54	4.86E+09	8.40E+07	1.45E+06	2.52E+04	4.35E+02	1.30E-01	3.90E-05	1.17E-08	0.00E+00	0.00E+00	0.00E+00	0.00E+00	0.00E+00	0.00E+00	0.00E+00	0.00E+00	0.00E+00	0.00E+00
Fe 55	7.33E+10	2.07E+10	5.86E+09	1.66E+09	4.69E+08	3.75E+07	2.99E+06	2.39E+05	1.53E+03	7.82E-01	0.00E+00	0.00E+00	0.00E+00	0.00E+00	0.00E+00	0.00E+00	0.00E+00	0.00E+00
Fe 59	1.04E+10	4.59E-03	0.00E+00	0.00E+00	0.00E+00	0.00E+00	0.00E+00	0.00E+00	0.00E+00	0.00E+00	0.00E+00	0.00E+00	0.00E+00	0.00E+00	0.00E+00	0.00E+00	0.00E+00	0.00E+00
Fe 60	2.58E+01	2.58E+01	2.58E+01	2.58E+01	2.58E+01	2.58E+01	2.58E+01	2.58E+01	2.58E+01	2.58E+01	2.58E+01	2.58E+01	2.58E+01	2.58E+01	2.57E+01	2.47E+01	1.63E+01	2.54E-01
Co 56	1.74E+03	1.32E-04	1.01E-11	7.66E-19	0.00E+00	0.00E+00	0.00E+00	0.00E+00	0.00E+00	0.00E+00	0.00E+00	0.00E+00	0.00E+00	0.00E+00	0.00E+00	0.00E+00	0.00E+00	0.00E+00
Co 57	4.65E+07	4.41E+05	4.18E+03	3.96E+01	3.75E-01	3.37E-05	3.03E-09	2.72E-13	0.00E+00	0.00E+00	0.00E+00	0.00E+00	0.00E+00	0.00E+00	0.00E+00	0.00E+00	0.00E+00	0.00E+00
Co 58	7.14E+09	1.25E+02	2.18E-06	0.00E+00	0.00E+00	0.00E+00	0.00E+00	0.00E+00	0.00E+00	0.00E+00	0.00E+00	0.00E+00	0.00E+00	0.00E+00	0.00E+00	0.00E+00	0.00E+00	0.00E+00
Co 60	8.41E+10	4.36E+10	2.26E+10	1.17E+10	6.06E+09	1.63E+09	4.37E+08	1.17E+08	8.44E+06	1.63E+05	2.61E+01	2.58E+01	2.58E+01	2.58E+01	2.56E+01	2.46E+01	1.62E+01	2.54E-01
Co 60m	4.26E+11	2.58E+01	2.58E+01	2.58E+01	2.58E+01	2.58E+01	2.58E+01	2.58E+01	2.58E+01	2.58E+01	2.58E+01	2.58E+01	2.58E+01	2.58E+01	2.57E+01	2.47E+01	1.63E+01	2.54E-01
Ni 59	1.10E+07	1.10E+07	1.10E+07	1.10E+07	1.10E+07	1.10E+07	1.10E+07	1.10E+07	1.10E+07	1.10E+07	1.10E+07	1.10E+07	1.10E+07	1.09E+07	1.01E+07	4.43E+06	1.21E+03	0.00E+00
Ni 63	1.52E+09	1.47E+09	1.42E+09	1.37E+09	1.33E+09	1.24E+09	1.16E+09	1.08E+09	9.41E+08	7.67E+08	3.86E+08	1.95E+08	4.95E+07	1.61E+06	0.00E+00	0.00E+00	0.00E+00	0.00E+00
Zn 65	9.11E+09	5.08E+07	2.83E+05	1.58E+03	8.78E+00	2.73E-04	8.47E-09	0.00E+00	0.00E+00	0.00E+00	0.00E+00	0.00E+00	0.00E+00	0.00E+00	0.00E+00	0.00E+00	0.00E+00	0.00E+00
Ga 68	9.71E+04	5.38E-08	5.03E-10	4.70E-12	4.39E-14	0.00E+00	0.00E+00	0.00E+00	0.00E+00	0.00E+00	0.00E+00	0.00E+00	0.00E+00	0.00E+00	0.00E+00	0.00E+00	0.00E+00	0.00E+00
Ge 68	5.76E-06	5.37E-08	5.03E-10	4.70E-12	4.40E-14	3.84E-18	1.32E-21	0.00E+00	0.00E+00	0.00E+00	0.00E+00	0.00E+00	0.00E+00	0.00E+00	0.00E+00	0.00E+00	0.00E+00	0.00E+00
Ge 73m	1.01E+07	7.61E-05	1.08E-11	0.00E+00	0.00E+00	0.00E+00	0.00E+00	0.00E+00	0.00E+00	0.00E+00	0.00E+00	0.00E+00	0.00E+00	0.00E+00	0.00E+00	0.00E+00	0.00E+00	0.00E+00
As 73	5.34E+02	7.61E-05	1.08E-11	1.54E-18	0.00E+00	0.00E+00	0.00E+00	0.00E+00	0.00E+00	0.00E+00	0.00E+00	0.00E+00	0.00E+00	0.00E+00	0.00E+00	0.00E+00	0.00E+00	0.00E+00
Se 75	2.90E+08	7.39E+03	1.90E-01	4.89E-06	1.26E-10	0.00E+00	0.00E+00	0.00E+00	0.00E+00	0.00E+00	0.00E+00	0.00E+00	0.00E+00	0.00E+00	0.00E+00	0.00E+00	0.00E+00	0.00E+00
Se 79	3.14E+02	3.14E+02	3.14E+02	3.14E+02	3.14E+02	3.14E+02	3.14E+02	3.14E+02	3.14E+02	3.11E+02	3.15E+02	3.13E+02	3.11E+02	3.14E+02	3.07E+02	2.48E+02	3.00E+01	1.96E-08
Kr 81	1.89E-04	1.68E-01	1.68E-01	1.89E-04	1.89E-04	1.89E-04	1.89E-04	3.37E-01	1.68E-01	1.18E+00	1.89E-04	1.89E-04	3.37E-01	1.88E-04	3.37E-01	1.40E-04	2.02E-01	1.35E-17
Kr 83m	3.14E+08	4.05E-05	1.70E-11	6.25E-19	0.00E+00	0.00E+00	0.00E+00	0.00E+00	0.00E+00	0.00E+00	0.00E+00	0.00E+00	0.00E+00	0.00E+00	0.00E+00	0.00E+00	0.00E+00	0.00E+00
Kr 85	5.97E+06	4.33E+06	3.13E+06	2.27E+06	1.64E+06	8.64E+05	4.53E+05	2.38E+05	6.56E+04	9.48E+03	1.51E+01	2.39E-02	6.04E-08	0.00E+00	0.00E+00	0.00E+00	0.00E+00	0.00E+00
Rb 83	1.29E+02	5.45E-05	2.28E-11	9.43E-18	0.00E+00	0.00E+00	0.00E+00	0.00E+00	0.00E+00	0.00E+00	0.00E+00	0.00E+00	0.00E+00	0.00E+00	0.00E+00	0.00E+00	0.00E+00	0.00E+00
Rb 84	2.80E+04	4.95E-13	0.00E+00	0.00E+00	0.00E+00	0.00E+00	0.00E+00	0.00E+00	0.00E+00	0.00E+00	0.00E+00	0.00E+00	0.00E+00	0.00E+00	0.00E+00	0.00E+00	0.00E+00	0.00E+00
Rb 87	1.72E-01	1.72E-01	1.72E-01	1.72E-01	1.72E-01	1.72E-01	1.72E-01	1.72E-01	1.72E-01	1.72E-01	1.72E-01	1.72E-01	1.72E-01	1.72E-01	1.72E-01	1.72E-01	1.72E-01	1.72E-01
Sr 85	2.00E+06	6.63E-03	2.20E-11	0.00E+00	0.00E+00	0.00E+00	0.00E+00	0.00E+00	0.00E+00	0.00E+00	0.00E+00	0.00E+00	0.00E+00	0.00E+00	0.00E+00	0.00E+00	0.00E+00	0.00E+00
Sr 89	6.72E+09	8.85E-02	0.00E+00	0.00E+00	0.00E+00	0.00E+00	0.00E+00	0.00E+00	0.00E+00	0.00E+00	0.00E+00	0.00E+00	0.00E+00	0.00E+00	0.00E+00	0.00E+00	0.00E+00	0.00E+00
Sr 90	4.04E+07	3.59E+07	3.18E+07	2.82E+07	2.50E+07	1.96E+07	1.54E+07	1.21E+07	7.50E+06	3.64E+06	3.28E+05	2.95E+04	2.39E+02	1.41E-03	0.00E+00	0.00E+00	0.00E+00	0.00E+00

Table 31: Zircaloy Cladding - Total Radionuclide Activity (Bq/Initial kg Zr)

290 MWh/kgU, 720 kW/bundle

Nuclide	0.0 Yrs	5.0 Yrs	10.0 Yrs	15.0 Yrs	20.0 Yrs	30.0 Yrs	40.0 Yrs	50.0 Yrs	70.0 Yrs	100.0 Yrs	200.0 Yrs	300.0 Yrs	500.0 Yrs	1.0E3 Yrs	1.0E4 Yrs	1.0E5 Yrs	1.0E6 Yrs	1.0E7 Yrs
Y 88	3.38E+06	2.36E+01	1.65E-04	1.15E-09	8.01E-15	0.00E+00	0.00E+00	0.00E+00	0.00E+00	0.00E+00	0.00E+00	0.00E+00	0.00E+00	0.00E+00	0.00E+00	0.00E+00	0.00E+00	0.00E+00
Y 89m	3.74E+10	8.53E-06	0.00E+00	0.00E+00	0.00E+00	0.00E+00	0.00E+00	0.00E+00	0.00E+00	0.00E+00	0.00E+00	0.00E+00	0.00E+00	0.00E+00	0.00E+00	0.00E+00	0.00E+00	0.00E+00
Y 90	6.10E+10	3.59E+07	3.18E+07	2.82E+07	2.50E+07	1.96E+07	1.54E+07	1.21E+07	7.50E+06	3.64E+06	3.28E+05	2.95E+04	2.39E+02	1.41E-03	0.00E+00	0.00E+00	0.00E+00	0.00E+00
Y 91	8.85E+09	3.56E+00	1.43E-09	0.00E+00	0.00E+00	0.00E+00	0.00E+00	0.00E+00	0.00E+00	0.00E+00	0.00E+00	0.00E+00	0.00E+00	0.00E+00	0.00E+00	0.00E+00	0.00E+00	0.00E+00
Zr 88	7.00E+02	1.79E-04	4.57E-11	1.17E-17	0.00E+00	0.00E+00	0.00E+00	0.00E+00	0.00E+00	0.00E+00	0.00E+00	0.00E+00	0.00E+00	0.00E+00	0.00E+00	0.00E+00	0.00E+00	0.00E+00
Zr 93	1.43E+07	1.43E+07	1.43E+07	1.43E+07	1.43E+07	1.43E+07	1.43E+07	1.43E+07	1.43E+07	1.43E+07	1.43E+07	1.43E+07	1.43E+07	1.43E+07	1.43E+07	1.37E+07	9.11E+06	1.54E+05
Zr 95	1.08E+13	2.79E+04	7.24E-05	0.00E+00	0.00E+00	0.00E+00	0.00E+00	0.00E+00	0.00E+00	0.00E+00	0.00E+00	0.00E+00	0.00E+00	0.00E+00	0.00E+00	0.00E+00	0.00E+00	0.00E+00
Zr 96	1.99E-04	1.99E-04	1.99E-04	1.99E-04	1.99E-04	1.99E-04	1.99E-04	1.99E-04	1.99E-04	1.99E-04	1.99E-04	1.99E-04	1.99E-04	1.99E-04	1.99E-04	1.99E-04	1.99E-04	1.99E-04
Nb 91	1.40E+03	1.46E+03	1.46E+03	1.45E+03	1.44E+03	1.43E+03	1.41E+03	1.40E+03	1.37E+03	1.33E+03	1.20E+03	1.08E+03	8.83E+02	5.30E+02	5.50E-02	0.00E+00	0.00E+00	0.00E+00
Nb 91m	3.08E+05	2.85E-04	2.63E-13	0.00E+00	0.00E+00	0.00E+00	0.00E+00	0.00E+00	0.00E+00	0.00E+00	0.00E+00	0.00E+00	0.00E+00	0.00E+00	0.00E+00	0.00E+00	0.00E+00	0.00E+00
Nb 92	1.21E+00	1.21E+00	1.21E+00	1.21E+00	1.21E+00	1.21E+00	1.21E+00	1.21E+00	1.21E+00	1.21E+00	1.21E+00	1.21E+00	1.21E+00	1.21E+00	1.21E+00	1.20E+00	1.20E+00	9.87E-01
Nb 93m	4.29E+07	3.73E+07	3.28E+07	2.92E+07	2.63E+07	2.20E+07	1.92E+07	1.74E+07	1.55E+07	1.44E+07	1.41E+07	1.40E+07	1.40E+07	1.40E+07	1.39E+07	1.33E+07	8.88E+06	1.50E+05
Nb 94	4.36E+06	4.36E+06	4.36E+06	4.36E+06	4.36E+06	4.36E+06	4.36E+06	4.36E+06	4.35E+06	4.35E+06	4.34E+06	4.32E+06	4.29E+06	4.22E+06	3.10E+06	1.44E+05	6.45E-09	0.00E+00
Nb 95	1.01E+13	6.16E+04	1.60E-04	0.00E+00	0.00E+00	0.00E+00	0.00E+00	0.00E+00	0.00E+00	0.00E+00	0.00E+00	0.00E+00	0.00E+00	0.00E+00	0.00E+00	0.00E+00	0.00E+00	0.00E+00
Nb 95m	1.16E+11	3.20E+02	8.29E-07	0.00E+00	0.00E+00	0.00E+00	0.00E+00	0.00E+00	0.00E+00	0.00E+00	0.00E+00	0.00E+00	0.00E+00	0.00E+00	0.00E+00	0.00E+00	0.00E+00	0.00E+00
Mo 93	9.18E+04	9.18E+04	9.17E+04	9.16E+04	9.15E+04	9.14E+04	9.12E+04	9.11E+04	9.07E+04	9.03E+04	8.87E+04	8.72E+04	8.42E+04	7.72E+04	1.62E+04	2.73E-03	0.00E+00	0.00E+00
Mo 100	8.02E-08	8.02E-08	8.02E-08	8.02E-08	8.02E-08	8.02E-08	8.02E-08	8.02E-08	8.02E-08	8.02E-08	8.02E-08	8.02E-08	8.02E-08	8.02E-08	8.02E-08	8.02E-08	8.02E-08	8.02E-08
Tc 95m	8.49E+00	8.19E-09	7.93E-18	0.00E+00	0.00E+00	0.00E+00	0.00E+00	0.00E+00	0.00E+00	0.00E+00	0.00E+00	0.00E+00	0.00E+00	0.00E+00	0.00E+00	0.00E+00	0.00E+00	0.00E+00
Tc 95	6.01E+01	3.23E-10	0.00E+00	0.00E+00	0.00E+00	0.00E+00	0.00E+00	0.00E+00	0.00E+00	0.00E+00	0.00E+00	0.00E+00	0.00E+00	0.00E+00	0.00E+00	0.00E+00	0.00E+00	0.00E+00
Tc 97m	4.43E+02	4.18E-04	3.79E-10	3.32E-16	0.00E+00	0.00E+00	0.00E+00	0.00E+00	0.00E+00	0.00E+00	0.00E+00	0.00E+00	0.00E+00	0.00E+00	0.00E+00	0.00E+00	0.00E+00	0.00E+00
Tc 97	1.81E-01	1.84E-01	1.84E-01	1.84E-01	1.84E-01	1.84E-01	1.84E-01	1.84E-01	1.84E-01	1.84E-01	1.84E-01	1.84E-01	1.84E-01	1.84E-01	1.83E-01	1.83E-01	1.80E-01	1.56E-01
Tc 98	9.62E-03	9.62E-03	9.62E-03	9.62E-03	9.62E-03	9.62E-03	9.62E-03	9.62E-03	9.62E-03	9.62E-03	9.62E-03	9.62E-03	9.62E-03	9.62E-03	9.62E-03	9.44E-03	8.13E-03	1.85E-03
Tc 99	2.24E+04	2.27E+04	2.27E+04	2.27E+04	2.27E+04	2.27E+04	2.27E+04	2.27E+04	2.27E+04	2.27E+04	2.27E+04	2.27E+04	2.26E+04	2.26E+04	2.19E+04	1.63E+04	8.50E+02	1.24E-10
Ru 103	3.12E+09	3.06E-05	0.00E+00	0.00E+00	0.00E+00	0.00E+00	0.00E+00	0.00E+00	0.00E+00	0.00E+00	0.00E+00	0.00E+00	0.00E+00	0.00E+00	0.00E+00	0.00E+00	0.00E+00	0.00E+00
Ru 106	6.63E+08	2.20E+07	7.31E+05	2.43E+04	8.05E+02	8.88E-01	9.79E-04	1.08E-06	1.31E-12	0.00E+00	0.00E+00	0.00E+00	0.00E+00	0.00E+00	0.00E+00	0.00E+00	0.00E+00	0.00E+00
Rh 101	1.97E+02	7.05E+01	2.47E+01	8.63E+00	3.02E+00	3.70E-01	4.52E-02	5.53E-03	8.29E-05	1.52E-07	1.12E-16	0.00E+00	0.00E+00	0.00E+00	0.00E+00	0.00E+00	0.00E+00	0.00E+00
Rh 102	5.90E+04	1.38E+02	3.00E+00	1.07E+00	4.25E-01	6.67E-02	1.05E-02	1.64E-03	4.04E-05	1.56E-07	2.62E-17	0.00E+00	0.00E+00	0.00E+00	0.00E+00	0.00E+00	0.00E+00	0.00E+00
Rh 102m	6.29E+03	2.49E+03	9.87E+02	3.91E+02	1.55E+02	2.43E+01	3.81E+00	5.97E-01	1.47E-02	5.67E-05	5.11E-13	0.00E+00	0.00E+00	0.00E+00	0.00E+00	0.00E+00	0.00E+00	0.00E+00
Rh 103m	3.20E+09	3.03E-05	0.00E+00	0.00E+00	0.00E+00	0.00E+00	0.00E+00	0.00E+00	0.00E+00	0.00E+00	0.00E+00	0.00E+00	0.00E+00	0.00E+00	0.00E+00	0.00E+00	0.00E+00	0.00E+00
Rh 106	1.24E+09	2.20E+07	7.31E+05	2.43E+04	8.05E+02	8.88E-01	9.79E-04	1.08E-06	1.31E-12	0.00E+00	0.00E+00	0.00E+00	0.00E+00	0.00E+00	0.00E+00	0.00E+00	0.00E+00	0.00E+00
Pd 107	1.87E+02	1.87E+02	1.87E+02	1.87E+02	1.87E+02	1.87E+02	1.87E+02	1.87E+02	1.87E+02	1.87E+02	1.87E+02	1.87E+02	1.87E+02	1.87E+02	1.86E+02	1.85E+02	1.68E+02	6.42E+01
Ag 105	9.64E+01	4.66E-12	0.00E+00	0.00E+00	0.00E+00	0.00E+00	0.00E+00	0.00E+00	0.00E+00	0.00E+00	0.00E+00	0.00E+00	0.00E+00	0.00E+00	0.00E+00	0.00E+00	0.00E+00	0.00E+00
Ag 108	5.01E+10	5.23E+04	5.19E+04	5.14E+04	5.10E+04	5.02E+04	4.95E+04	4.87E+04	4.72E+04	4.50E+04	3.84E+04	3.28E+04	2.39E+04	1.08E+04	7.05E-03	0.00E+00	0.00E+00	0.00E+00

Table 31: Zircaloy Cladding - Total Radionuclide Activity (Bq/Initial kg Zr)

290 MWh/kgU, 720 kW/bundle

Nuclide	0.0 Yrs	5.0 Yrs	10.0 Yrs	15.0 Yrs	20.0 Yrs	30.0 Yrs	40.0 Yrs	50.0 Yrs	70.0 Yrs	100.0 Yrs	200.0 Yrs	300.0 Yrs	500.0 Yrs	1.0E3 Yrs	1.0E4 Yrs	1.0E5 Yrs	1.0E6 Yrs	1.0E7 Yrs
Ag 108m	6.06E+05	6.01E+05	5.96E+05	5.92E+05	5.87E+05	5.78E+05	5.69E+05	5.60E+05	5.42E+05	5.17E+05	4.41E+05	3.77E+05	2.74E+05	1.24E+05	8.10E-02	0.00E+00	0.00E+00	0.00E+00
Ag 109m	2.07E+10	3.27E+06	2.11E+05	1.35E+04	8.71E+02	3.60E+00	1.49E-02	6.17E-05	1.06E-09	0.00E+00	0.00E+00	0.00E+00	0.00E+00	0.00E+00	0.00E+00	0.00E+00	0.00E+00	0.00E+00
Ag 110	1.17E+11	2.92E+05	1.84E+03	1.16E+01	7.28E-02	2.88E-06	1.14E-10	0.00E+00	0.00E+00	0.00E+00	0.00E+00	0.00E+00	0.00E+00	0.00E+00	0.00E+00	0.00E+00	0.00E+00	0.00E+00
Ag 110m	3.42E+09	2.15E+07	1.35E+05	8.50E+02	5.35E+00	2.12E-04	8.38E-09	0.00E+00	0.00E+00	0.00E+00	0.00E+00	0.00E+00	0.00E+00	0.00E+00	0.00E+00	0.00E+00	0.00E+00	0.00E+00
Cd 109	5.09E+07	3.27E+06	2.11E+05	1.35E+04	8.71E+02	3.60E+00	1.49E-02	6.17E-05	1.06E-09	0.00E+00	0.00E+00	0.00E+00	0.00E+00	0.00E+00	0.00E+00	0.00E+00	0.00E+00	0.00E+00
Cd 113m	1.71E+04	1.34E+04	1.05E+04	8.20E+03	6.41E+03	3.92E+03	2.40E+03	1.47E+03	5.49E+02	1.25E+02	9.19E-01	6.74E-03	3.61E-07	7.62E-18	0.00E+00	0.00E+00	0.00E+00	0.00E+00
Cd 113	2.16E-10	2.18E-10	2.18E-10	2.18E-10	2.18E-10	2.18E-10	2.18E-10	2.18E-10	2.18E-10	2.18E-10	2.18E-10	2.18E-10	2.18E-10	2.18E-10	2.18E-10	2.18E-10	2.18E-10	2.18E-10
Cd 115m	3.30E+07	1.51E-05	0.00E+00	0.00E+00	0.00E+00	0.00E+00	0.00E+00	0.00E+00	0.00E+00	0.00E+00	0.00E+00	0.00E+00	0.00E+00	0.00E+00	0.00E+00	0.00E+00	0.00E+00	0.00E+00
Cd 116	2.30E-10	2.30E-10	2.30E-10	2.30E-10	2.30E-10	2.30E-10	2.30E-10	2.30E-10	2.30E-10	2.30E-10	2.30E-10	2.30E-10	2.30E-10	2.30E-10	2.30E-10	2.30E-10	2.30E-10	2.30E-10
In 113m	2.21E+11	3.69E+06	6.17E+01	1.03E-03	1.72E-08	0.00E+00	0.00E+00	0.00E+00	0.00E+00	0.00E+00	0.00E+00	0.00E+00	0.00E+00	0.00E+00	0.00E+00	0.00E+00	0.00E+00	0.00E+00
In 114m	5.54E+09	4.35E-02	0.00E+00	0.00E+00	0.00E+00	0.00E+00	0.00E+00	0.00E+00	0.00E+00	0.00E+00	0.00E+00	0.00E+00	0.00E+00	0.00E+00	0.00E+00	0.00E+00	0.00E+00	0.00E+00
In 114	1.16E+10	4.21E-02	0.00E+00	0.00E+00	0.00E+00	0.00E+00	0.00E+00	0.00E+00	0.00E+00	0.00E+00	0.00E+00	0.00E+00	0.00E+00	0.00E+00	0.00E+00	0.00E+00	0.00E+00	0.00E+00
In 115	6.99E-06	6.99E-06	6.99E-06	6.99E-06	6.99E-06	6.99E-06	6.99E-06	6.99E-06	6.99E-06	6.99E-06	6.99E-06	6.99E-06	6.99E-06	6.99E-06	6.99E-06	6.99E-06	6.99E-06	6.99E-06
In 115m	5.91E+08	1.61E-09	0.00E+00	0.00E+00	0.00E+00	0.00E+00	0.00E+00	0.00E+00	0.00E+00	0.00E+00	0.00E+00	0.00E+00	0.00E+00	0.00E+00	0.00E+00	0.00E+00	0.00E+00	0.00E+00
Sn 113	2.21E+11	3.69E+06	6.16E+01	1.03E-03	1.72E-08	0.00E+00	0.00E+00	0.00E+00	0.00E+00	0.00E+00	0.00E+00	0.00E+00	0.00E+00	0.00E+00	0.00E+00	0.00E+00	0.00E+00	0.00E+00
Sn 119m	3.27E+11	4.34E+09	5.78E+07	7.68E+05	1.02E+04	1.80E+00	3.18E-04	5.62E-08	0.00E+00	0.00E+00	0.00E+00	0.00E+00	0.00E+00	0.00E+00	0.00E+00	0.00E+00	0.00E+00	0.00E+00
Sn 121	8.16E+11	8.23E+07	7.61E+07	7.03E+07	6.49E+07	5.54E+07	4.73E+07	4.04E+07	2.95E+07	1.84E+07	3.78E+06	7.80E+05	3.32E+04	1.24E+01	0.00E+00	0.00E+00	0.00E+00	0.00E+00
Sn 121m	1.15E+08	1.06E+08	9.80E+07	9.05E+07	8.37E+07	7.15E+07	6.10E+07	5.21E+07	3.80E+07	2.37E+07	4.88E+06	1.01E+06	4.27E+04	1.59E+01	0.00E+00	0.00E+00	0.00E+00	0.00E+00
Sn 123	1.29E+09	7.16E+04	3.97E+00	2.21E-04	1.23E-08	0.00E+00	0.00E+00	0.00E+00	0.00E+00	0.00E+00	0.00E+00	0.00E+00	0.00E+00	0.00E+00	0.00E+00	0.00E+00	0.00E+00	0.00E+00
Sn 126	1.87E+02	1.87E+02	1.87E+02	1.87E+02	1.87E+02	1.87E+02	1.87E+02	1.87E+02	1.87E+02	1.87E+02	1.87E+02	1.87E+02	1.86E+02	1.86E+02	1.81E+02	1.38E+02	9.17E+00	1.52E-11
Sb 124	5.17E+09	3.81E+00	2.80E-09	0.00E+00	0.00E+00	0.00E+00	0.00E+00	0.00E+00	0.00E+00	0.00E+00	0.00E+00	0.00E+00	0.00E+00	0.00E+00	0.00E+00	0.00E+00	0.00E+00	0.00E+00
Sb 125	6.82E+10	1.95E+10	5.54E+09	1.58E+09	4.49E+08	3.64E+07	2.95E+06	2.39E+05	1.57E+03	8.34E-01	0.00E+00	0.00E+00	0.00E+00	0.00E+00	0.00E+00	0.00E+00	0.00E+00	0.00E+00
Sb 126m	5.48E+08	1.87E+02	1.87E+02	1.87E+02	1.87E+02	1.87E+02	1.87E+02	1.87E+02	1.87E+02	1.87E+02	1.87E+02	1.87E+02	1.86E+02	1.86E+02	1.81E+02	1.38E+02	9.17E+00	1.52E-11
Sb 126	2.37E+09	2.61E+01	2.61E+01	2.61E+01	2.61E+01	2.61E+01	2.61E+01	2.61E+01	2.61E+01	2.61E+01	2.61E+01	2.61E+01	2.61E+01	2.61E+01	2.54E+01	1.93E+01	1.28E+00	2.13E-12
Te 121	1.82E+07	6.78E+02	3.04E-01	1.36E-04	6.11E-08	0.00E+00	0.00E+00	0.00E+00	0.00E+00	0.00E+00	0.00E+00	0.00E+00	0.00E+00	0.00E+00	0.00E+00	0.00E+00	0.00E+00	0.00E+00
Te 121m	1.51E+06	6.76E+02	3.03E-01	1.36E-04	6.09E-08	1.23E-14	0.00E+00	0.00E+00	0.00E+00	0.00E+00	0.00E+00	0.00E+00	0.00E+00	0.00E+00	0.00E+00	0.00E+00	0.00E+00	0.00E+00
Te 123m	2.48E+08	6.05E+03	1.48E-01	3.60E-06	8.80E-11	0.00E+00	0.00E+00	0.00E+00	0.00E+00	0.00E+00	0.00E+00	0.00E+00	0.00E+00	0.00E+00	0.00E+00	0.00E+00	0.00E+00	0.00E+00
Te 125m	1.20E+10	4.76E+09	1.36E+09	3.86E+08	1.10E+08	8.91E+06	7.22E+05	5.85E+04	3.84E+02	2.04E-01	0.00E+00	0.00E+00	0.00E+00	0.00E+00	0.00E+00	0.00E+00	0.00E+00	0.00E+00
Te 127	1.10E+09	2.60E+02	2.35E-03	2.13E-08	1.92E-13	0.00E+00	0.00E+00	0.00E+00	0.00E+00	0.00E+00	0.00E+00	0.00E+00	0.00E+00	0.00E+00	0.00E+00	0.00E+00	0.00E+00	0.00E+00
Te 127m	2.81E+07	2.66E+02	2.40E-03	2.17E-08	1.96E-13	0.00E+00	0.00E+00	0.00E+00	0.00E+00	0.00E+00	0.00E+00	0.00E+00	0.00E+00	0.00E+00	0.00E+00	0.00E+00	0.00E+00	0.00E+00
Te 128	3.74E-08	3.74E-08	3.74E-08	3.74E-08	3.74E-08	3.74E-08	3.74E-08	3.74E-08	3.74E-08	3.74E-08	3.74E-08	3.74E-08	3.74E-08	3.74E-08	3.74E-08	3.74E-08	3.74E-08	3.74E-08
Te 129	1.06E+09	2.15E-09	0.00E+00	0.00E+00	0.00E+00	0.00E+00	0.00E+00	0.00E+00	0.00E+00	0.00E+00	0.00E+00	0.00E+00	0.00E+00	0.00E+00	0.00E+00	0.00E+00	0.00E+00	0.00E+00
Te 129m	7.81E+07	3.41E-09	0.00E+00	0.00E+00	0.00E+00	0.00E+00	0.00E+00	0.00E+00	0.00E+00	0.00E+00	0.00E+00	0.00E+00	0.00E+00	0.00E+00	0.00E+00	0.00E+00	0.00E+00	0.00E+00
I 125	2.93E+06	1.65E-03	9.03E-13	0.00E+00	0.00E+00	0.00E+00	0.00E+00	0.00E+00	0.00E+00	0.00E+00	0.00E+00	0.00E+00	0.00E+00	0.00E+00	0.00E+00	0.00E+00	0.00E+00	0.00E+00
I 129	3.62E+01	3.67E+01	3.67E+01	3.67E+01	3.67E+01	3.67E+01	3.67E+01	3.67E+01	3.67E+01	3.67E+01	3.67E+01	3.67E+01	3.67E+01	3.67E+01	3.66E+01	3.65E+01	3.51E+01	2.36E+01

Table 31: Zircaloy Cladding - Total Radionuclide Activity (Bq/Initial kg Zr)

290 MWh/kgU, 720 kW/bundle

Nuclide	0.0 Yrs	5.0 Yrs	10.0 Yrs	15.0 Yrs	20.0 Yrs	30.0 Yrs	40.0 Yrs	50.0 Yrs	70.0 Yrs	100.0 Yrs	200.0 Yrs	300.0 Yrs	500.0 Yrs	1.0E3 Yrs	1.0E4 Yrs	1.0E5 Yrs	1.0E6 Yrs	1.0E7 Yrs
Xe 127	3.46E+05	2.76E-10	0.00E+00	0.00E+00	0.00E+00	0.00E+00	0.00E+00	0.00E+00	0.00E+00	0.00E+00	0.00E+00	0.00E+00	0.00E+00	0.00E+00	0.00E+00	0.00E+00	0.00E+00	0.00E+00
Cs 134	1.09E+09	2.03E+08	3.79E+07	7.07E+06	1.32E+06	4.62E+04	1.60E+03	5.59E+01	6.79E-02	2.88E-06	0.00E+00	0.00E+00	0.00E+00	0.00E+00	0.00E+00	0.00E+00	0.00E+00	0.00E+00
Cs 135	2.89E+02	2.91E+02	2.91E+02	2.91E+02	2.91E+02	2.91E+02	2.91E+02	2.91E+02	2.91E+02	2.91E+02	2.91E+02	2.91E+02	2.91E+02	2.91E+02	2.90E+02	2.82E+02	2.15E+02	1.43E+01
Cs 137	6.68E+07	5.95E+07	5.31E+07	4.73E+07	4.21E+07	3.35E+07	2.66E+07	2.11E+07	1.33E+07	6.67E+06	6.66E+05	6.64E+04	6.62E+02	6.55E-03	0.00E+00	0.00E+00	0.00E+00	0.00E+00
Ba 133	1.53E+05	1.10E+05	7.94E+04	5.71E+04	4.11E+04	2.12E+04	1.10E+04	5.69E+03	1.52E+03	2.11E+02	2.89E-01	3.96E-04	7.45E-10	0.00E+00	0.00E+00	0.00E+00	0.00E+00	0.00E+00
Ba 137m	7.08E+07	5.64E+07	5.03E+07	4.48E+07	3.99E+07	3.17E+07	2.52E+07	2.00E+07	1.26E+07	6.31E+06	6.30E+05	6.29E+04	6.26E+02	6.20E-03	0.00E+00	0.00E+00	0.00E+00	0.00E+00
La 137	9.26E+00	9.29E+00	9.31E+00	9.32E+00	9.31E+00	9.31E+00	9.31E+00	9.29E+00	9.31E+00	9.29E+00	9.26E+00	9.31E+00	9.26E+00	9.20E+00	8.28E+00	2.93E+00	8.92E-05	0.00E+00
La 138	5.40E-05	5.40E-05	5.40E-05	5.40E-05	5.40E-05	5.40E-05	5.40E-05	5.40E-05	5.40E-05	5.40E-05	5.40E-05	5.40E-05	5.40E-05	5.40E-05	5.40E-05	5.40E-05	5.40E-05	5.40E-05
Ce 139	1.40E+05	1.42E+01	1.44E-03	1.45E-07	1.48E-11	0.00E+00	0.00E+00	0.00E+00	0.00E+00	0.00E+00	0.00E+00	0.00E+00	0.00E+00	0.00E+00	0.00E+00	0.00E+00	0.00E+00	0.00E+00
Ce 141	2.71E+09	3.33E-08	0.00E+00	0.00E+00	0.00E+00	0.00E+00	0.00E+00	0.00E+00	0.00E+00	0.00E+00	0.00E+00	0.00E+00	0.00E+00	0.00E+00	0.00E+00	0.00E+00	0.00E+00	0.00E+00
Ce 144	1.26E+09	1.48E+07	1.74E+05	2.04E+03	2.40E+01	3.32E-03	4.59E-07	6.34E-11	0.00E+00	0.00E+00	0.00E+00	0.00E+00	0.00E+00	0.00E+00	0.00E+00	0.00E+00	0.00E+00	0.00E+00
Pr 144	1.30E+09	1.48E+07	1.74E+05	2.04E+03	2.40E+01	3.32E-03	4.59E-07	6.34E-11	0.00E+00	0.00E+00	0.00E+00	0.00E+00	0.00E+00	0.00E+00	0.00E+00	0.00E+00	0.00E+00	0.00E+00
Pr 144m	4.28E+07	1.41E+05	1.66E+03	1.95E+01	2.29E-01	3.17E-05	4.38E-09	6.05E-13	0.00E+00	0.00E+00	0.00E+00	0.00E+00	0.00E+00	0.00E+00	0.00E+00	0.00E+00	0.00E+00	0.00E+00
Nd 144	9.15E-07	1.34E-06	1.34E-06	1.34E-06	1.34E-06	1.34E-06	1.34E-06	1.34E-06	1.34E-06	1.34E-06	1.34E-06	1.34E-06	1.34E-06	1.34E-06	1.34E-06	1.34E-06	1.34E-06	1.34E-06
Nd 150	5.86E-11	5.86E-11	5.86E-11	5.86E-11	5.86E-11	5.86E-11	5.86E-11	5.86E-11	5.86E-11	5.86E-11	5.86E-11	5.86E-11	5.86E-11	5.86E-11	5.86E-11	5.86E-11	5.86E-11	5.86E-11
Pm 143	1.12E+00	9.39E-03	7.94E-05	6.66E-07	5.62E-09	3.97E-13	2.84E-17	2.00E-21	0.00E+00	0.00E+00	0.00E+00	0.00E+00	0.00E+00	0.00E+00	0.00E+00	0.00E+00	0.00E+00	0.00E+00
Pm 144	1.20E+01	3.66E-01	1.12E-02	3.44E-04	1.05E-05	9.81E-09	9.19E-12	8.59E-15	7.49E-21	0.00E+00	0.00E+00	0.00E+00	0.00E+00	0.00E+00	0.00E+00	0.00E+00	0.00E+00	0.00E+00
Pm 145	3.07E+03	9.36E+03	7.88E+03	6.46E+03	5.32E+03	3.63E+03	2.42E+03	1.64E+03	7.53E+02	2.32E+02	4.61E+00	9.23E-02	3.66E-05	1.14E-13	0.00E+00	0.00E+00	0.00E+00	0.00E+00
Pm 146	6.90E+01	3.69E+01	1.98E+01	1.05E+01	5.63E+00	1.61E+00	4.56E-01	1.31E-01	1.07E-02	2.48E-04	8.92E-10	3.21E-15	0.00E+00	0.00E+00	0.00E+00	0.00E+00	0.00E+00	0.00E+00
Pm 147	1.52E+08	4.37E+07	1.16E+07	3.11E+06	8.29E+05	5.90E+04	4.20E+03	2.99E+02	1.52E+00	5.47E-04	0.00E+00	0.00E+00	0.00E+00	0.00E+00	0.00E+00	0.00E+00	0.00E+00	0.00E+00
Pm 148	2.24E+08	3.28E-08	0.00E+00	0.00E+00	0.00E+00	0.00E+00	0.00E+00	0.00E+00	0.00E+00	0.00E+00	0.00E+00	0.00E+00	0.00E+00	0.00E+00	0.00E+00	0.00E+00	0.00E+00	0.00E+00
Pm 148m	1.40E+07	6.79E-07	0.00E+00	0.00E+00	0.00E+00	0.00E+00	0.00E+00	0.00E+00	0.00E+00	0.00E+00	0.00E+00	0.00E+00	0.00E+00	0.00E+00	0.00E+00	0.00E+00	0.00E+00	0.00E+00
Sm 145	1.55E+05	3.76E+03	9.02E+01	2.18E+00	5.27E-02	3.07E-05	1.79E-08	1.04E-11	0.00E+00	0.00E+00	0.00E+00	0.00E+00	0.00E+00	0.00E+00	0.00E+00	0.00E+00	0.00E+00	0.00E+00
Sm 146	8.06E-04	8.06E-04	8.05E-04	8.06E-04	8.08E-04	8.08E-04	8.08E-04	8.08E-04	8.08E-04	8.08E-04	8.08E-04	8.08E-04	8.08E-04	8.08E-04	8.08E-04	8.06E-04	8.00E-04	7.55E-04
Sm 147	2.29E-03	5.26E-03	6.05E-03	6.26E-03	6.32E-03	6.34E-03	6.34E-03	6.34E-03	6.34E-03	6.34E-03	6.34E-03	6.34E-03	6.34E-03	6.34E-03	6.34E-03	6.34E-03	6.34E-03	6.34E-03
Sm 148	4.95E-08	5.02E-08	5.02E-08	5.02E-08	5.02E-08	5.02E-08	5.02E-08	5.02E-08	5.02E-08	5.02E-08	5.02E-08	5.02E-08	5.02E-08	5.02E-08	5.02E-08	5.02E-08	5.02E-08	5.02E-08
Sm 151	1.38E+05	1.46E+05	1.40E+05	1.35E+05	1.30E+05	1.20E+05	1.11E+05	1.03E+05	8.85E+04	7.02E+04	3.25E+04	1.51E+04	3.22E+03	6.85E+01	0.00E+00	0.00E+00	0.00E+00	0.00E+00
Eu 148	5.43E-07	4.42E-17	0.00E+00	0.00E+00	0.00E+00	0.00E+00	0.00E+00	0.00E+00	0.00E+00	0.00E+00	0.00E+00	0.00E+00	0.00E+00	0.00E+00	0.00E+00	0.00E+00	0.00E+00	0.00E+00
Eu 149	2.45E-02	3.05E-08	3.78E-14	4.72E-20	0.00E+00	0.00E+00	0.00E+00	0.00E+00	0.00E+00	0.00E+00	0.00E+00	0.00E+00	0.00E+00	0.00E+00	0.00E+00	0.00E+00	0.00E+00	0.00E+00
Eu 150	7.79E-01	7.12E-01	6.43E-01	5.87E-01	5.34E-01	4.44E-01	3.65E-01	3.04E-01	2.09E-01	1.19E-01	1.82E-02	2.79E-03	6.49E-05	5.43E-09	0.00E+00	0.00E+00	0.00E+00	0.00E+00
Eu 152	1.44E+02	1.12E+02	8.65E+01	6.70E+01	5.18E+01	3.11E+01	1.86E+01	1.11E+01	4.01E+00	8.61E-01	5.14E-03	3.07E-05	1.10E-09	0.00E+00	0.00E+00	0.00E+00	0.00E+00	0.00E+00

Table 31: Zircaloy Cladding - Total Radionuclide Activity (Bq/Initial kg Zr)

290 MWh/kgU, 720 kW/bundle

Nuclide	0.0 Yrs	5.0 Yrs	10.0 Yrs	15.0 Yrs	20.0 Yrs	30.0 Yrs	40.0 Yrs	50.0 Yrs	70.0 Yrs	100.0 Yrs	200.0 Yrs	300.0 Yrs	500.0 Yrs	1.0E3 Yrs	1.0E4 Yrs	1.0E5 Yrs	1.0E6 Yrs	1.0E7 Yrs
Eu 154	1.19E+07	7.91E+06	5.28E+06	3.53E+06	2.36E+06	1.05E+06	4.71E+05	2.11E+05	4.22E+04	3.73E+03	1.18E+00	3.74E-04	3.73E-11	0.00E+00	0.00E+00	0.00E+00	0.00E+00	0.00E+00
Eu 155	1.03E+07	4.99E+06	2.40E+06	1.16E+06	5.64E+05	1.30E+05	3.03E+04	7.04E+03	3.79E+02	4.79E+00	2.22E-06	1.03E-12	0.00E+00	0.00E+00	0.00E+00	0.00E+00	0.00E+00	0.00E+00
Gd 148	1.24E-09	1.18E-09	1.13E-09	1.08E-09	1.03E-09	9.38E-10	8.53E-10	7.75E-10	6.47E-10	4.89E-10	1.93E-10	7.63E-11	1.19E-11	1.14E-13	0.00E+00	0.00E+00	0.00E+00	0.00E+00
Gd 150	1.78E-05	1.78E-05	1.78E-05	1.79E-05	1.79E-05	1.79E-05	1.79E-05	1.79E-05	1.79E-05	1.79E-05	1.78E-05	1.78E-05	1.78E-05	1.78E-05	1.78E-05	1.72E-05	1.21E-05	3.72E-07
Gd 151	3.28E+02	1.21E-02	4.45E-07	1.63E-11	6.03E-16	0.00E+00	0.00E+00	0.00E+00	0.00E+00	0.00E+00	0.00E+00	0.00E+00	0.00E+00	0.00E+00	0.00E+00	0.00E+00	0.00E+00	0.00E+00
Gd 152	3.19E-07	3.19E-07	3.19E-07	3.19E-07	3.19E-07	3.19E-07	3.19E-07	3.20E-07	3.20E-07	3.20E-07	3.20E-07	3.20E-07	3.20E-07	3.20E-07	3.20E-07	3.20E-07	3.20E-07	3.20E-07
Gd 153	3.06E+06	1.58E+04	8.17E+01	4.21E-01	2.18E-03	5.81E-08	1.55E-12	0.00E+00	0.00E+00	0.00E+00	0.00E+00	0.00E+00	0.00E+00	0.00E+00	0.00E+00	0.00E+00	0.00E+00	0.00E+00
Tb 157	2.31E+04	2.21E+04	2.10E+04	2.00E+04	1.91E+04	1.73E+04	1.57E+04	1.42E+04	1.17E+04	8.73E+03	3.29E+03	1.24E+03	1.76E+02	1.33E+00	0.00E+00	0.00E+00	0.00E+00	0.00E+00
Tb 158	4.70E+03	4.61E+03	4.52E+03	4.43E+03	4.34E+03	4.18E+03	4.02E+03	3.87E+03	3.59E+03	3.19E+03	2.17E+03	1.48E+03	6.84E+02	9.97E+01	8.83E-14	0.00E+00	0.00E+00	0.00E+00
Tb 160	1.18E+09	2.99E+01	7.34E-07	0.00E+00	0.00E+00	0.00E+00	0.00E+00	0.00E+00	0.00E+00	0.00E+00	0.00E+00	0.00E+00	0.00E+00	0.00E+00	0.00E+00	0.00E+00	0.00E+00	0.00E+00
Dy 154	2.89E-09	2.89E-09	2.89E-09	2.89E-09	2.89E-09	2.89E-09	2.89E-09	2.89E-09	2.89E-09	2.89E-09	2.89E-09	2.89E-09	2.89E-09	2.89E-09	2.88E-09	2.82E-09	2.29E-09	2.87E-10
Dy 159	3.80E+05	5.91E+01	9.21E-03	1.43E-06	2.24E-10	0.00E+00	0.00E+00	0.00E+00	0.00E+00	0.00E+00	0.00E+00	0.00E+00	0.00E+00	0.00E+00	0.00E+00	0.00E+00	0.00E+00	0.00E+00
Ho 163	3.46E+02	3.45E+02	3.45E+02	3.45E+02	3.45E+02	3.44E+02	3.44E+02	3.43E+02	3.42E+02	3.40E+02	3.36E+02	3.30E+02	3.21E+02	2.97E+02	7.59E+01	8.94E-05	0.00E+00	0.00E+00
Ho 166m	1.20E+04	1.19E+04	1.19E+04	1.19E+04	1.18E+04	1.18E+04	1.17E+04	1.16E+04	1.15E+04	1.13E+04	1.07E+04	1.01E+04	8.96E+03	6.72E+03	3.71E+01	0.00E+00	0.00E+00	0.00E+00
Tm 168	1.69E+04	2.10E-02	2.61E-08	3.24E-14	0.00E+00	0.00E+00	0.00E+00	0.00E+00	0.00E+00	0.00E+00	0.00E+00	0.00E+00	0.00E+00	0.00E+00	0.00E+00	0.00E+00	0.00E+00	0.00E+00
Tm 170	1.36E+09	7.17E+04	3.81E+00	2.02E-04	1.07E-08	0.00E+00	0.00E+00	0.00E+00	0.00E+00	0.00E+00	0.00E+00	0.00E+00	0.00E+00	0.00E+00	0.00E+00	0.00E+00	0.00E+00	0.00E+00
Tm 171	7.16E+07	1.18E+07	1.94E+06	3.19E+05	5.25E+04	1.42E+03	3.84E+01	1.04E+00	7.58E-04	1.50E-08	0.00E+00	0.00E+00	0.00E+00	0.00E+00	0.00E+00	0.00E+00	0.00E+00	0.00E+00
Yb 169	3.20E+03	2.16E-14	0.00E+00	0.00E+00	0.00E+00	0.00E+00	0.00E+00	0.00E+00	0.00E+00	0.00E+00	0.00E+00	0.00E+00	0.00E+00	0.00E+00	0.00E+00	0.00E+00	0.00E+00	0.00E+00
Lu 172m	4.67E-01	5.78E-02	9.06E-03	1.42E-03	2.22E-04	5.46E-06	1.34E-07	3.29E-09	2.04E-12	0.00E+00	0.00E+00	0.00E+00	0.00E+00	0.00E+00	0.00E+00	0.00E+00	0.00E+00	0.00E+00
Lu 172	9.46E-01	5.78E-02	9.06E-03	1.42E-03	2.25E-04	5.51E-06	1.35E-07	3.32E-09	2.00E-12	2.96E-17	0.00E+00	0.00E+00	0.00E+00	0.00E+00	0.00E+00	0.00E+00	0.00E+00	0.00E+00
Lu 173	2.57E+04	2.05E+03	1.64E+02	1.30E+01	1.04E+00	6.59E-03	4.18E-05	2.65E-07	1.07E-11	0.00E+00	0.00E+00	0.00E+00	0.00E+00	0.00E+00	0.00E+00	0.00E+00	0.00E+00	0.00E+00
Lu 174	7.06E+04	3.08E+04	1.08E+04	3.79E+03	1.33E+03	1.64E+02	2.02E+01	2.49E+00	3.77E-02	7.05E-05	5.66E-14	0.00E+00	0.00E+00	0.00E+00	0.00E+00	0.00E+00	0.00E+00	0.00E+00
Lu 174m	1.30E+05	1.75E+01	2.35E-03	3.15E-07	4.23E-11	0.00E+00	0.00E+00	0.00E+00	0.00E+00	0.00E+00	0.00E+00	0.00E+00	0.00E+00	0.00E+00	0.00E+00	0.00E+00	0.00E+00	0.00E+00
Lu 176	2.63E-03	2.63E-03	2.63E-03	2.63E-03	2.63E-03	2.63E-03	2.63E-03	2.63E-03	2.63E-03	2.63E-03	2.63E-03	2.63E-03	2.63E-03	2.63E-03	2.63E-03	2.63E-03	2.63E-03	2.62E-03
Lu 177m	2.44E+06	9.12E+02	3.41E-01	1.28E-04	4.78E-08	6.69E-15	0.00E+00	0.00E+00	0.00E+00	0.00E+00	0.00E+00	0.00E+00	0.00E+00	0.00E+00	0.00E+00	0.00E+00	0.00E+00	0.00E+00
Lu 177	2.55E+09	2.03E+02	7.62E-02	2.85E-05	1.07E-08	0.00E+00	0.00E+00	0.00E+00	0.00E+00	0.00E+00	0.00E+00	0.00E+00	0.00E+00	0.00E+00	0.00E+00	0.00E+00	0.00E+00	0.00E+00
Hf 172	3.69E-01	5.78E-02	9.06E-03	1.42E-03	2.22E-04	5.46E-06	1.34E-07	3.29E-09	1.98E-12	2.94E-17	0.00E+00	0.00E+00	0.00E+00	0.00E+00	0.00E+00	0.00E+00	0.00E+00	0.00E+00
Hf 174	1.23E-06	1.23E-06	1.23E-06	1.23E-06	1.23E-06	1.23E-06	1.23E-06	1.23E-06	1.23E-06	1.23E-06	1.23E-06	1.23E-06	1.23E-06	1.23E-06	1.23E-06	1.23E-06	1.23E-06	1.23E-06
Hf 175	9.20E+09	1.29E+02	1.80E-06	0.00E+00	0.00E+00	0.00E+00	0.00E+00	0.00E+00	0.00E+00	0.00E+00	0.00E+00	0.00E+00	0.00E+00	0.00E+00	0.00E+00	0.00E+00	0.00E+00	0.00E+00
Hf 177m	6.69E+08	7.17E+02	2.68E-01	1.00E-04	3.76E-08	0.00E+00	0.00E+00	0.00E+00	0.00E+00	0.00E+00	0.00E+00	0.00E+00	0.00E+00	0.00E+00	0.00E+00	0.00E+00	0.00E+00	0.00E+00
Hf 181	2.00E+11	2.14E-02	0.00E+00	0.00E+00	0.00E+00	0.00E+00	0.00E+00	0.00E+00	0.00E+00	0.00E+00	0.00E+00	0.00E+00	0.00E+00	0.00E+00	0.00E+00	0.00E+00	0.00E+00	0.00E+00
Hf 182	4.59E+02	4.59E+02	4.59E+02	4.59E+02	4.59E+02	4.59E+02	4.59E+02	4.59E+02	4.59E+02	4.59E+02	4.59E+02	4.59E+02	4.59E+02	4.59E+02	4.59E+02	4.56E+02	4.25E+02	2.11E+02

Table 31: Zircaloy Cladding - Total Radionuclide Activity (Bq/Initial kg Zr)

290 MWh/kgU, 720 kW/bundle

Nuclide	0.0 Yrs	5.0 Yrs	10.0 Yrs	15.0 Yrs	20.0 Yrs	30.0 Yrs	40.0 Yrs	50.0 Yrs	70.0 Yrs	100.0 Yrs	200.0 Yrs	300.0 Yrs	500.0 Yrs	1.0E3 Yrs	1.0E4 Yrs	1.0E5 Yrs	1.0E6 Yrs	1.0E7 Yrs
Ta 179	2.00E+05	2.98E+04	4.44E+03	6.61E+02	9.84E+01	2.18E+00	4.84E-02	1.07E-03	5.27E-07	5.75E-12	0.00E+00	0.00E+00	0.00E+00	0.00E+00	0.00E+00	0.00E+00	0.00E+00	0.00E+00
Ta 182	9.18E+10	1.48E+06	4.83E+02	4.59E+02	4.59E+02	4.59E+02	4.59E+02	4.59E+02	4.59E+02	4.59E+02	4.59E+02	4.59E+02	4.59E+02	4.59E+02	4.59E+02	4.56E+02	4.25E+02	2.11E+02
W 180	3.59E-09	3.59E-09	3.59E-09	3.59E-09	3.59E-09	3.59E-09	3.59E-09	3.59E-09	3.59E-09	3.59E-09	3.59E-09	3.59E-09	3.59E-09	3.59E-09	3.59E-09	3.59E-09	3.59E-09	3.59E-09
W 181	1.36E+09	3.96E+04	1.15E+00	3.35E-05	9.74E-10	0.00E+00	0.00E+00	0.00E+00	0.00E+00	0.00E+00	0.00E+00	0.00E+00	0.00E+00	0.00E+00	0.00E+00	0.00E+00	0.00E+00	0.00E+00
W 185	2.88E+10	1.37E+03	6.56E-05	0.00E+00	0.00E+00	0.00E+00	0.00E+00	0.00E+00	0.00E+00	0.00E+00	0.00E+00	0.00E+00	0.00E+00	0.00E+00	0.00E+00	0.00E+00	0.00E+00	0.00E+00
W 186	8.69E-09	8.69E-09	8.69E-09	8.69E-09	8.69E-09	8.69E-09	8.69E-09	8.69E-09	8.69E-09	8.69E-09	8.69E-09	8.69E-09	8.69E-09	8.69E-09	8.69E-09	8.69E-09	8.69E-09	8.69E-09
W 188	1.00E+09	1.33E+01	1.75E-07	0.00E+00	0.00E+00	0.00E+00	0.00E+00	0.00E+00	0.00E+00	0.00E+00	0.00E+00	0.00E+00	0.00E+00	0.00E+00	0.00E+00	0.00E+00	0.00E+00	0.00E+00
Re 183	1.78E+02	2.49E-06	3.49E-14	0.00E+00	0.00E+00	0.00E+00	0.00E+00	0.00E+00	0.00E+00	0.00E+00	0.00E+00	0.00E+00	0.00E+00	0.00E+00	0.00E+00	0.00E+00	0.00E+00	0.00E+00
Re 184m	2.00E+03	1.12E+00	6.23E-04	3.48E-07	1.94E-10	6.04E-17	0.00E+00	0.00E+00	0.00E+00	0.00E+00	0.00E+00	0.00E+00	0.00E+00	0.00E+00	0.00E+00	0.00E+00	0.00E+00	0.00E+00
Re 184	2.63E+04	1.05E+00	5.87E-04	3.28E-07	1.83E-10	0.00E+00	0.00E+00	0.00E+00	0.00E+00	0.00E+00	0.00E+00	0.00E+00	0.00E+00	0.00E+00	0.00E+00	0.00E+00	0.00E+00	0.00E+00
Re 186m	2.09E+01	2.09E+01	2.09E+01	2.09E+01	2.08E+01	2.08E+01	2.08E+01	2.08E+01	2.08E+01	2.08E+01	2.08E+01	2.08E+01	2.08E+01	2.08E+01	2.08E+01	2.01E+01	1.47E+01	6.51E-01
Re 186	1.06E+10	2.09E+01	2.09E+01	2.09E+01	2.08E+01	2.08E+01	2.08E+01	2.08E+01	2.08E+01	2.08E+01	2.08E+01	2.08E+01	2.08E+01	2.08E+01	2.08E+01	2.01E+01	1.47E+01	6.51E-01
Re 187	6.09E+00	6.13E+00	6.13E+00	6.13E+00	6.13E+00	6.13E+00	6.13E+00	6.13E+00	6.13E+00	6.13E+00	6.13E+00	6.13E+00	6.13E+00	6.13E+00	6.13E+00	6.13E+00	6.13E+00	6.13E+00
Re 188	1.29E+11	1.34E+01	1.77E-07	0.00E+00	0.00E+00	0.00E+00	0.00E+00	0.00E+00	0.00E+00	0.00E+00	0.00E+00	0.00E+00	0.00E+00	0.00E+00	0.00E+00	0.00E+00	0.00E+00	0.00E+00
Os 185	5.82E+05	7.60E-01	1.04E-06	1.42E-12	0.00E+00	0.00E+00	0.00E+00	0.00E+00	0.00E+00	0.00E+00	0.00E+00	0.00E+00	0.00E+00	0.00E+00	0.00E+00	0.00E+00	0.00E+00	0.00E+00
Os 186	1.23E-06	1.28E-06	1.28E-06	1.28E-06	1.28E-06	1.28E-06	1.28E-06	1.28E-06	1.28E-06	1.28E-06	1.28E-06	1.28E-06	1.28E-06	1.28E-06	1.28E-06	1.28E-06	1.28E-06	1.28E-06
Os 194	1.79E+03	1.01E+03	5.45E+02	3.17E+02	1.79E+02	5.45E+01	1.76E+01	5.43E+00	5.40E-01	1.70E-02	1.65E-07	1.57E-12	0.00E+00	0.00E+00	0.00E+00	0.00E+00	0.00E+00	0.00E+00
Ir 192	3.86E+08	1.38E+01	4.92E-07	0.00E+00	0.00E+00	0.00E+00	0.00E+00	0.00E+00	0.00E+00	0.00E+00	0.00E+00	0.00E+00	0.00E+00	0.00E+00	0.00E+00	0.00E+00	0.00E+00	0.00E+00
Ir 194	6.39E+09	9.84E+02	5.76E+02	3.16E+02	1.76E+02	5.73E+01	1.76E+01	5.72E+00	5.39E-01	1.70E-02	1.64E-07	1.61E-12	0.00E+00	0.00E+00	0.00E+00	0.00E+00	0.00E+00	0.00E+00
Pt 190	1.28E-05	1.28E-05	1.28E-05	1.28E-05	1.28E-05	1.28E-05	1.28E-05	1.28E-05	1.28E-05	1.28E-05	1.28E-05	1.28E-05	1.28E-05	1.28E-05	1.28E-05	1.28E-05	1.28E-05	1.28E-05
Pt 193	1.82E+06	1.70E+06	1.59E+06	1.48E+06	1.39E+06	1.21E+06	1.05E+06	9.14E+05	6.92E+05	4.57E+05	1.14E+05	2.85E+04	1.78E+03	1.74E+00	0.00E+00	0.00E+00	0.00E+00	0.00E+00
Au 194	3.82E-04	4.06E-06	4.03E-06	3.99E-06	3.97E-06	3.89E-06	3.83E-06	3.78E-06	3.66E-06	3.49E-06	2.97E-06	2.56E-06	1.87E-06	8.57E-07	6.78E-13	0.00E+00	0.00E+00	0.00E+00
Au 195	1.02E+02	1.13E-01	1.25E-04	1.39E-07	1.55E-10	1.91E-16	0.00E+00	0.00E+00	0.00E+00	0.00E+00	0.00E+00	0.00E+00	0.00E+00	0.00E+00	0.00E+00	0.00E+00	0.00E+00	0.00E+00
Hg 194	4.10E-06	4.06E-06	4.03E-06	3.99E-06	3.97E-06	3.89E-06	3.83E-06	3.78E-06	3.66E-06	3.49E-06	2.97E-06	2.56E-06	1.87E-06	8.57E-07	6.78E-13	0.00E+00	0.00E+00	0.00E+00
Hg 203	9.77E+07	1.55E-04	0.00E+00	0.00E+00	0.00E+00	0.00E+00	0.00E+00	0.00E+00	0.00E+00	0.00E+00	0.00E+00	0.00E+00	0.00E+00	0.00E+00	0.00E+00	0.00E+00	0.00E+00	0.00E+00
Hg 206	1.07E+02	1.05E-08	8.97E-09	7.67E-09	6.56E-09	4.81E-09	3.52E-09	2.59E-09	1.42E-09	6.34E-10	5.15E-10	1.52E-09	4.22E-09	1.66E-08	6.70E-07	5.98E-06	1.09E-05	1.07E-05
Tl 202	2.84E+04	2.74E-03	2.74E-03	2.74E-03	2.74E-03	2.74E-03	2.74E-03	2.74E-03	2.74E-03	2.74E-03	2.73E-03	2.73E-03	2.72E-03	2.71E-03	2.40E-03	7.32E-04	5.05E-09	0.00E+00
Tl 204	1.73E+07	7.02E+06	2.76E+06	1.10E+06	4.47E+05	7.01E+04	1.13E+04	1.82E+03	4.68E+01	1.94E-01	2.10E-09	0.00E+00	0.00E+00	0.00E+00	0.00E+00	0.00E+00	0.00E+00	0.00E+00
Tl 206	3.79E+06	3.91E-01	3.91E-01	3.91E-01	3.91E-01	3.91E-01	3.91E-01	3.91E-01	3.91E-01	3.91E-01	3.91E-01	3.91E-01	3.92E-01	3.88E-01	3.88E-01	3.82E-01	3.13E-01	4.06E-02
Pb 202	2.74E-03	2.74E-03	2.74E-03	2.74E-03	2.74E-03	2.74E-03	2.74E-03	2.74E-03	2.74E-03	2.74E-03	2.73E-03	2.73E-03	2.72E-03	2.71E-03	2.40E-03	7.32E-04	5.05E-09	0.00E+00
Pb 204	7.04E-07	7.04E-07	7.04E-07	7.04E-07	7.04E-07	7.04E-07	7.04E-07	7.04E-07	7.04E-07	7.04E-07	7.04E-07	7.04E-07	7.04E-07	7.04E-07	7.04E-07	7.04E-07	7.04E-07	7.04E-07
Pb 205	1.48E+01	1.48E+01	1.48E+01	1.48E+01	1.48E+01	1.48E+01	1.48E+01	1.48E+01	1.48E+01	1.48E+01	1.48E+01	1.48E+01	1.48E+01	1.48E+01	1.48E+01	1.47E+01	1.42E+01	9.90E+00

Table 31: Zircaloy Cladding - Total Radionuclide Activity (Bq/Initial kg Zr)

290 MWh/kgU, 720 kW/bundle

Nuclide	0.0 Yrs	5.0 Yrs	10.0 Yrs	15.0 Yrs	20.0 Yrs	30.0 Yrs	40.0 Yrs	50.0 Yrs	70.0 Yrs	100.0 Yrs	200.0 Yrs	300.0 Yrs	500.0 Yrs	1.0E3 Yrs	1.0E4 Yrs	1.0E5 Yrs	1.0E6 Yrs	1.0E7 Yrs
Pb 209	1.49E+00	2.23E-01	2.98E-01	3.73E-01	4.47E-01	5.97E-01	7.46E-01	8.95E-01	1.19E+00	1.64E+00	3.11E+00	4.58E+00	7.46E+00	1.45E+01	1.02E+02	2.87E+02	4.02E+02	2.05E+01
Pb 210	6.39E-01	5.52E-01	4.72E-01	4.04E-01	3.46E-01	2.53E-01	1.85E-01	1.36E-01	7.46E-02	3.34E-02	2.71E-02	8.01E-02	2.22E-01	8.72E-01	3.53E+01	3.15E+02	5.72E+02	5.61E+02
Pb 211	3.68E-01	5.88E+00	1.06E+01	1.46E+01	1.80E+01	2.35E+01	2.74E+01	3.03E+01	3.39E+01	3.63E+01	3.77E+01	3.77E+01	3.76E+01	3.72E+01	3.17E+01	1.52E+01	1.41E+01	1.40E+01
Pb 212	2.67E+03	1.54E+04	1.67E+04	1.62E+04	1.55E+04	1.40E+04	1.27E+04	1.15E+04	9.38E+03	6.94E+03	2.54E+03	9.28E+02	1.24E+02	8.99E-01	8.90E-02	9.02E-02	1.02E-01	2.08E-01
Pb 214	1.23E-05	5.46E-05	1.37E-04	2.60E-04	4.25E-04	8.79E-04	1.50E-03	2.30E-03	4.40E-03	8.87E-03	3.54E-02	8.00E-02	2.22E-01	8.72E-01	3.53E+01	3.15E+02	5.72E+02	5.60E+02
Bi 207	5.45E+00	4.87E+00	4.36E+00	3.88E+00	3.52E+00	2.84E+00	2.24E+00	1.81E+00	1.16E+00	6.06E-01	6.68E-02	7.43E-03	9.19E-05	1.55E-09	0.00E+00	0.00E+00	0.00E+00	0.00E+00
Bi 208	7.29E-01	7.26E-01	7.26E-01	7.24E-01	7.24E-01	7.24E-01	7.25E-01	7.26E-01	7.26E-01	7.29E-01	7.26E-01	7.29E-01	7.26E-01	7.26E-01	7.13E-01	6.04E-01	1.11E-01	4.81E-09
Bi 209	1.26E-09	1.26E-09	1.26E-09	1.26E-09	1.26E-09	1.26E-09	1.26E-09	1.26E-09	1.26E-09	1.26E-09	1.26E-09	1.26E-09	1.26E-09	1.26E-09	1.26E-09	1.26E-09	1.28E-09	1.32E-09
Bi 210m	3.91E-01	3.91E-01	3.91E-01	3.91E-01	3.91E-01	3.91E-01	3.91E-01	3.91E-01	3.91E-01	3.91E-01	3.91E-01	3.91E-01	3.92E-01	3.88E-01	3.88E-01	3.82E-01	3.12E-01	3.99E-02
Bi 210	4.36E+06	5.52E-01	4.72E-01	4.04E-01	3.46E-01	2.53E-01	1.86E-01	1.36E-01	7.46E-02	3.34E-02	2.71E-02	8.01E-02	2.22E-01	8.72E-01	3.53E+01	3.15E+02	5.72E+02	5.61E+02
Po 208	3.13E-03	9.44E-04	2.85E-04	8.64E-05	2.62E-05	2.39E-06	2.18E-07	2.00E-08	1.67E-10	1.28E-13	0.00E+00	0.00E+00	0.00E+00	0.00E+00	0.00E+00	0.00E+00	0.00E+00	0.00E+00
Po 209	1.25E-01	1.21E-01	1.17E-01	1.13E-01	1.09E-01	1.02E-01	9.50E-02	8.91E-02	7.77E-02	6.33E-02	3.21E-02	1.62E-02	4.14E-03	1.39E-04	0.00E+00	0.00E+00	0.00E+00	0.00E+00
Po 210	3.30E+06	3.68E+02	5.11E-01	4.04E-01	3.46E-01	2.53E-01	1.86E-01	1.36E-01	7.46E-02	3.34E-02	2.71E-02	8.01E-02	2.22E-01	8.72E-01	3.53E+01	3.15E+02	5.72E+02	5.61E+02
Po 211	1.02E-03	1.62E-02	2.93E-02	4.04E-02	4.98E-02	6.48E-02	7.56E-02	8.35E-02	9.34E-02	1.00E-01	1.04E-01	1.04E-01	1.04E-01	1.03E-01	8.75E-02	4.19E-02	3.89E-02	3.86E-02
Po 212	1.72E+03	9.86E+03	1.07E+04	1.04E+04	9.94E+03	8.99E+03	8.13E+03	7.35E+03	6.01E+03	4.44E+03	1.63E+03	5.94E+02	7.95E+01	5.76E-01	5.70E-02	5.78E-02	6.55E-02	1.33E-01
Po 213	1.45E+00	2.18E-01	2.91E-01	3.64E-01	4.37E-01	5.84E-01	7.29E-01	8.75E-01	1.17E+00	1.60E+00	3.05E+00	4.48E+00	7.30E+00	1.41E+01	9.98E+01	2.81E+02	3.93E+02	2.01E+01
Po 214	1.48E+00	5.46E-05	1.37E-04	2.60E-04	4.25E-04	8.79E-04	1.50E-03	2.30E-03	4.40E-03	8.87E-03	3.54E-02	8.00E-02	2.22E-01	8.72E-01	3.53E+01	3.15E+02	5.72E+02	5.60E+02
Po 215	3.65E-01	5.88E+00	1.06E+01	1.46E+01	1.80E+01	2.35E+01	2.74E+01	3.03E+01	3.39E+01	3.63E+01	3.77E+01	3.77E+01	3.76E+01	3.72E+01	3.17E+01	1.52E+01	1.41E+01	1.40E+01
Po 216	2.67E+03	1.54E+04	1.67E+04	1.62E+04	1.55E+04	1.40E+04	1.27E+04	1.15E+04	9.38E+03	6.94E+03	2.54E+03	9.28E+02	1.24E+02	8.99E-01	8.90E-02	9.02E-02	1.02E-01	2.08E-01
Po 218	1.23E-05	5.46E-05	1.37E-04	2.60E-04	4.25E-04	8.79E-04	1.50E-03	2.30E-03	4.40E-03	8.87E-03	3.54E-02	8.00E-02	2.22E-01	8.72E-01	3.53E+01	3.15E+02	5.72E+02	5.61E+02
Tl 207	3.67E-01	5.87E+00	1.06E+01	1.46E+01	1.80E+01	2.34E+01	2.73E+01	3.02E+01	3.38E+01	3.62E+01	3.76E+01	3.76E+01	3.75E+01	3.71E+01	3.16E+01	1.51E+01	1.41E+01	1.40E+01
Tl 208	9.65E+02	5.53E+03	6.01E+03	5.84E+03	5.58E+03	5.04E+03	4.56E+03	4.13E+03	3.37E+03	2.49E+03	9.12E+02	3.33E+02	4.46E+01	3.23E-01	3.20E-02	3.24E-02	3.68E-02	7.46E-02
Tl 209	3.26E-02	4.91E-03	6.55E-03	8.20E-03	9.84E-03	1.31E-02	1.64E-02	1.97E-02	2.62E-02	3.60E-02	6.85E-02	1.01E-01	1.64E-01	3.18E-01	2.25E+00	6.32E+00	8.83E+00	4.51E-01
Tl 210	3.88E-09	1.15E-08	2.87E-08	5.46E-08	8.92E-08	1.85E-07	3.15E-07	4.82E-07	9.24E-07	1.86E-06	7.44E-06	1.68E-05	4.66E-05	1.83E-04	7.41E-03	6.61E-02	1.20E-01	1.18E-01
Bi 211	3.68E-01	5.88E+00	1.06E+01	1.46E+01	1.80E+01	2.35E+01	2.74E+01	3.03E+01	3.39E+01	3.63E+01	3.77E+01	3.77E+01	3.76E+01	3.72E+01	3.17E+01	1.52E+01	1.41E+01	1.40E+01
Bi 212	2.69E+03	1.54E+04	1.67E+04	1.62E+04	1.55E+04	1.40E+04	1.27E+04	1.15E+04	9.38E+03	6.94E+03	2.54E+03	9.28E+02	1.24E+02	8.99E-01	8.90E-02	9.02E-02	1.02E-01	2.08E-01
Bi 213	1.48E+00	2.23E-01	2.98E-01	3.73E-01	4.47E-01	5.97E-01	7.46E-01	8.95E-01	1.19E+00	1.64E+00	3.11E+00	4.58E+00	7.46E+00	1.45E+01	1.02E+02	2.87E+02	4.01E+02	2.05E+01
Bi 214	1.23E-05	5.46E-05	1.37E-04	2.60E-04	4.25E-04	8.79E-04	1.50E-03	2.30E-03	4.40E-03	8.87E-03	3.54E-02	8.00E-02	2.22E-01	8.72E-01	3.53E+01	3.15E+02	5.72E+02	5.61E+02
At 217	1.48E+00	2.23E-01	2.98E-01	3.73E-01	4.47E-01	5.97E-01	7.46E-01	8.95E-01	1.19E+00	1.64E+00	3.11E+00	4.58E+00	7.46E+00	1.45E+01	1.02E+02	2.87E+02	4.02E+02	2.05E+01
At 218	2.47E-09	1.09E-08	2.74E-08	5.20E-08	8.50E-08	1.76E-07	3.00E-07	4.59E-07	8.80E-07	1.77E-06	7.09E-06	1.60E-05	4.44E-05	1.74E-04	7.06E-03	6.29E-02	1.14E-01	1.12E-01
Rn 217	1.04E-04	1.56E-05	2.08E-05	2.61E-05	3.13E-05	4.18E-05	5.22E-05	6.26E-05	8.35E-05	1.15E-04	2.18E-04	3.20E-04	5.22E-04	1.01E-03	7.14E-03	2.01E-02	2.81E-02	1.44E-03
Rn 218	1.48E+00	1.09E-11	2.74E-11	5.20E-11	8.50E-11	1.76E-10	3.00E-10	4.59E-10	8.80E-10	1.77E-09	7.09E-09	1.60E-08	4.44E-08	1.74E-07	7.06E-06	6.29E-05	1.14E-04	1.12E-04
Rn 219	3.65E-01	5.88E+00	1.06E+01	1.46E+01	1.80E+01	2.35E+01	2.74E+01	3.03E+01	3.39E+01	3.63E+01	3.77E+01	3.77E+01	3.76E+01	3.72E+01	3.17E+01	1.52E+01	1.41E+01	1.40E+01
Rn 220	2.67E+03	1.54E+04	1.67E+04	1.62E+04	1.55E+04	1.40E+04	1.27E+04	1.15E+04	9.38E+03	6.94E+03	2.54E+03	9.28E+02	1.24E+02	8.99E-01	8.90E-02	9.02E-02	1.02E-01	2.08E-01
Rn 222	1.23E-05	5.46E-05	1.37E-04	2.60E-04	4.25E-04	8.79E-04	1.50E-03	2.30E-03	4.40E-03	8.87E-03	3.54E-02	8.00E-02	2.22E-01	8.72E-01	3.53E+01	3.15E+02	5.72E+02	5.61E+02

Table 31: Zircaloy Cladding - Total Radionuclide Activity (Bq/Initial kg Zr)

290 MWh/kgU, 720 kW/bundle

Nuclide	0.0 Yrs	5.0 Yrs	10.0 Yrs	15.0 Yrs	20.0 Yrs	30.0 Yrs	40.0 Yrs	50.0 Yrs	70.0 Yrs	100.0 Yrs	200.0 Yrs	300.0 Yrs	500.0 Yrs	1.0E3 Yrs	1.0E4 Yrs	1.0E5 Yrs	1.0E6 Yrs	1.0E7 Yrs
Fr 221	1.48E+00	2.23E-01	2.98E-01	3.73E-01	4.47E-01	5.97E-01	7.46E-01	8.95E-01	1.19E+00	1.64E+00	3.11E+00	4.58E+00	7.46E+00	1.45E+01	1.02E+02	2.87E+02	4.02E+02	2.05E+01
Fr 223	4.89E-03	8.12E-02	1.46E-01	2.02E-01	2.49E-01	3.24E-01	3.78E-01	4.18E-01	4.67E-01	5.01E-01	5.21E-01	5.21E-01	5.19E-01	5.14E-01	4.38E-01	2.09E-01	1.95E-01	1.93E-01
Ra 223	3.65E-01	5.88E+00	1.06E+01	1.46E+01	1.80E+01	2.35E+01	2.74E+01	3.03E+01	3.39E+01	3.63E+01	3.77E+01	3.77E+01	3.76E+01	3.72E+01	3.17E+01	1.52E+01	1.41E+01	1.40E+01
Ra 224	2.67E+03	1.54E+04	1.67E+04	1.62E+04	1.55E+04	1.40E+04	1.27E+04	1.15E+04	9.38E+03	6.94E+03	2.54E+03	9.28E+02	1.24E+02	8.99E-01	8.90E-02	9.02E-02	1.02E-01	2.08E-01
Ra 225	1.82E+00	2.23E-01	2.98E-01	3.73E-01	4.47E-01	5.97E-01	7.46E-01	8.95E-01	1.19E+00	1.64E+00	3.11E+00	4.58E+00	7.46E+00	1.45E+01	1.02E+02	2.87E+02	4.02E+02	2.05E+01
Ra 226	1.29E-05	5.46E-05	1.37E-04	2.60E-04	4.25E-04	8.79E-04	1.50E-03	2.30E-03	4.40E-03	8.87E-03	3.54E-02	8.00E-02	2.22E-01	8.72E-01	3.53E+01	3.15E+02	5.72E+02	5.61E+02
Ra 228	1.24E-02	4.70E-02	6.60E-02	7.63E-02	8.20E-02	8.68E-02	8.83E-02	8.87E-02	8.89E-02	8.89E-02	8.89E-02	8.89E-02	8.89E-02	8.89E-02	8.90E-02	9.02E-02	1.02E-01	2.08E-01
Ac 225	1.48E+00	2.23E-01	2.98E-01	3.73E-01	4.47E-01	5.97E-01	7.46E-01	8.95E-01	1.19E+00	1.64E+00	3.11E+00	4.58E+00	7.46E+00	1.45E+01	1.02E+02	2.87E+02	4.02E+02	2.05E+01
Ac 227	3.54E-01	5.88E+00	1.06E+01	1.46E+01	1.80E+01	2.35E+01	2.74E+01	3.03E+01	3.39E+01	3.63E+01	3.77E+01	3.77E+01	3.76E+01	3.72E+01	3.17E+01	1.52E+01	1.41E+01	1.40E+01
Ac 228	4.71E+01	4.70E-02	6.60E-02	7.63E-02	8.20E-02	8.68E-02	8.83E-02	8.87E-02	8.89E-02	8.89E-02	8.89E-02	8.89E-02	8.89E-02	8.89E-02	8.90E-02	9.02E-02	1.02E-01	2.08E-01
Th 227	3.67E-01	5.80E+00	1.05E+01	1.44E+01	1.78E+01	2.31E+01	2.70E+01	2.98E+01	3.34E+01	3.58E+01	3.72E+01	3.72E+01	3.71E+01	3.67E+01	3.13E+01	1.50E+01	1.39E+01	1.38E+01
Th 228	2.73E+03	1.54E+04	1.67E+04	1.62E+04	1.55E+04	1.40E+04	1.27E+04	1.15E+04	9.38E+03	6.94E+03	2.54E+03	9.28E+02	1.24E+02	8.99E-01	8.90E-02	9.02E-02	1.02E-01	2.08E-01
Th 229	1.49E-01	2.23E-01	2.98E-01	3.73E-01	4.47E-01	5.97E-01	7.46E-01	8.95E-01	1.19E+00	1.64E+00	3.11E+00	4.58E+00	7.46E+00	1.45E+01	1.02E+02	2.87E+02	4.02E+02	2.05E+01
Th 230	9.84E-03	2.86E-02	4.76E-02	6.67E-02	8.60E-02	1.25E-01	1.65E-01	2.05E-01	2.88E-01	4.14E-01	8.57E-01	1.32E+00	2.25E+00	4.61E+00	4.54E+01	3.15E+02	5.72E+02	5.61E+02
Th 231	9.52E+04	3.92E+00	3.92E+00	3.92E+00	3.92E+00	3.92E+00	3.93E+00	3.93E+00	3.94E+00	3.95E+00	3.97E+00	4.00E+00	4.06E+00	4.20E+00	6.46E+00	1.35E+01	1.41E+01	1.40E+01
Th 232	8.89E-02	8.89E-02	8.89E-02	8.89E-02	8.89E-02	8.89E-02	8.89E-02	8.89E-02	8.89E-02	8.89E-02	8.89E-02	8.89E-02	8.89E-02	8.89E-02	8.90E-02	9.02E-02	1.02E-01	2.08E-01
Th 234	2.63E+04	5.61E+02	5.61E+02	5.61E+02	5.61E+02	5.61E+02	5.61E+02	5.61E+02	5.61E+02	5.61E+02	5.61E+02	5.61E+02	5.61E+02	5.61E+02	5.61E+02	5.61E+02	5.61E+02	5.61E+02
Pa 231	3.79E+01	3.79E+01	3.79E+01	3.79E+01	3.79E+01	3.79E+01	3.79E+01	3.79E+01	3.79E+01	3.78E+01	3.78E+01	3.77E+01	3.76E+01	3.72E+01	3.17E+01	1.52E+01	1.41E+01	1.40E+01
Pa 232	1.81E+06	2.59E-07	2.59E-07	2.59E-07	2.59E-07	2.59E-07	2.59E-07	2.59E-07	2.59E-07	2.59E-07	2.58E-07	2.58E-07	2.58E-07	2.58E-07	2.47E-07	1.64E-07	2.79E-09	0.00E+00
Pa 233	7.78E+07	6.11E+01	6.22E+01	6.39E+01	6.60E+01	7.10E+01	7.68E+01	8.31E+01	9.60E+01	1.16E+02	1.75E+02	2.26E+02	3.07E+02	4.25E+02	5.19E+02	5.04E+02	3.77E+02	2.05E+01
Pa 234	1.34E+06	8.98E-01	8.98E-01	8.98E-01	8.98E-01	8.98E-01	8.98E-01	8.98E-01	8.98E-01	8.98E-01	8.98E-01	8.98E-01	8.98E-01	8.98E-01	8.98E-01	8.98E-01	8.98E-01	8.97E-01
Pa 234m	1.44E+06	5.61E+02	5.61E+02	5.61E+02	5.61E+02	5.61E+02	5.61E+02	5.61E+02	5.61E+02	5.61E+02	5.61E+02	5.61E+02	5.61E+02	5.61E+02	5.61E+02	5.61E+02	5.61E+02	5.61E+02
U 232	1.84E+04	1.75E+04	1.67E+04	1.59E+04	1.51E+04	1.36E+04	1.23E+04	1.12E+04	9.12E+03	6.75E+03	2.47E+03	9.02E+02	1.21E+02	7.88E-01	1.69E-05	1.13E-05	1.91E-07	3.73E-25
U 233	1.23E+02	1.59E+02	1.59E+02	1.59E+02	1.59E+02	1.59E+02	1.59E+02	1.59E+02	1.59E+02	1.59E+02	1.59E+02	1.59E+02	1.59E+02	1.59E+02	1.73E+02	2.82E+02	4.01E+02	2.05E+01
U 234	4.06E+02	4.10E+02	4.14E+02	4.18E+02	4.22E+02	4.29E+02	4.36E+02	4.42E+02	4.53E+02	4.66E+02	4.94E+02	5.06E+02	5.15E+02	5.17E+02	5.18E+02	5.28E+02	5.59E+02	5.61E+02
U 235	3.92E+00	3.92E+00	3.92E+00	3.92E+00	3.92E+00	3.92E+00	3.93E+00	3.93E+00	3.94E+00	3.95E+00	3.97E+00	4.00E+00	4.06E+00	4.20E+00	6.46E+00	1.35E+01	1.41E+01	1.40E+01
U 236	9.84E+01	9.85E+01	9.86E+01	9.87E+01	9.88E+01	9.90E+01	9.92E+01	9.94E+01	9.97E+01	1.00E+02	1.02E+02	1.04E+02	1.08E+02	1.16E+02	2.16E+02	2.77E+02	2.70E+02	2.07E+02
U 237	3.61E+08	1.31E+03	1.03E+03	8.09E+02	6.35E+02	3.91E+02	2.41E+02	1.48E+02	5.61E+01	1.31E+01	1.03E-01	9.88E-04	1.84E-04	1.77E-04	8.49E-05	5.51E-08	0.00E+00	0.00E+00
U 238	5.61E+02	5.61E+02	5.61E+02	5.61E+02	5.61E+02	5.61E+02	5.61E+02	5.61E+02	5.61E+02	5.61E+02	5.61E+02	5.61E+02	5.61E+02	5.61E+02	5.61E+02	5.61E+02	5.61E+02	5.61E+02
U 240	7.60E+05	1.79E-04	1.79E-04	1.79E-04	1.79E-04	1.79E-04	1.79E-04	1.79E-04	1.79E-04	1.79E-04	1.79E-04	1.79E-04	1.79E-04	1.79E-04	1.79E-04	1.79E-04	1.77E-04	1.64E-04
Np 235	3.82E-01	1.56E-02	6.40E-04	2.62E-05	1.07E-06	1.80E-09	3.02E-12	5.06E-15	1.42E-20	0.00E+00	0.00E+00	0.00E+00	0.00E+00	0.00E+00	0.00E+00	0.00E+00	0.00E+00	0.00E+00
Np 236	1.29E-04	1.29E-04	1.29E-04	1.29E-04	1.29E-04	1.29E-04	1.29E-04	1.29E-04	1.29E-04	1.29E-04	1.29E-04	1.29E-04	1.29E-04	1.29E-04	1.24E-04	8.22E-05	1.39E-06	2.72E-24
Np 237	5.75E+01	6.11E+01	6.22E+01	6.39E+01	6.60E+01	7.10E+01	7.68E+01	8.31E+01	9.60E+01	1.16E+02	1.75E+02	2.26E+02	3.07E+02	4.25E+02	5.19E+02	5.04E+02	3.77E+02	2.05E+01
Np 238	1.23E+08	2.46E+00	2.40E+00	2.34E+00	2.29E+00	2.18E+00	2.07E+00	1.97E+00	1.79E+00	1.54E+00	9.43E-01	5.77E-01	2.16E-01	1.85E-02	0.00E+00	0.00E+00	0.00E+00	0.00E+00

Table 31: Zircaloy Cladding - Total Radionuclide Activity (Bq/Initial kg Zr)

290 MWh/kgU, 720 kW/bundle

Nuclide	0.0 Yrs	5.0 Yrs	10.0 Yrs	15.0 Yrs	20.0 Yrs	30.0 Yrs	40.0 Yrs	50.0 Yrs	70.0 Yrs	100.0 Yrs	200.0 Yrs	300.0 Yrs	500.0 Yrs	1.0E3 Yrs	1.0E4 Yrs	1.0E5 Yrs	1.0E6 Yrs	1.0E7 Yrs
Np 239	5.12E+10	5.16E+03	5.16E+03	5.16E+03	5.15E+03	5.15E+03	5.14E+03	5.14E+03	5.13E+03	5.12E+03	5.07E+03	5.02E+03	4.93E+03	4.70E+03	2.02E+03	4.25E-01	2.03E-06	1.36E-06
Np 240	6.54E+07	2.14E-07	2.14E-07	2.14E-07	2.14E-07	2.14E-07	2.14E-07	2.14E-07	2.14E-07	2.14E-07	2.14E-07	2.14E-07	2.14E-07	2.14E-07	2.14E-07	2.14E-07	2.13E-07	1.97E-07
Np 240m	1.13E+08	1.79E-04	1.79E-04	1.79E-04	1.79E-04	1.79E-04	1.79E-04	1.79E-04	1.79E-04	1.79E-04	1.79E-04	1.79E-04	1.79E-04	1.79E-04	1.79E-04	1.79E-04	1.77E-04	1.64E-04
Pu 236	4.64E+01	1.40E+01	4.15E+00	1.24E+00	3.68E-01	3.25E-02	2.89E-03	2.72E-04	1.94E-05	1.75E-05	1.74E-05	1.74E-05	1.74E-05	1.74E-05	1.67E-05	1.11E-05	1.88E-07	0.00E+00
Pu 237	2.23E+02	2.01E-10	0.00E+00	0.00E+00	0.00E+00	0.00E+00	0.00E+00	0.00E+00	0.00E+00	0.00E+00	0.00E+00	0.00E+00	0.00E+00	0.00E+00	0.00E+00	0.00E+00	0.00E+00	0.00E+00
Pu 238	2.54E+05	2.98E+05	2.87E+05	2.76E+05	2.65E+05	2.45E+05	2.26E+05	2.09E+05	1.79E+05	1.41E+05	6.41E+04	2.91E+04	6.04E+03	1.18E+02	5.37E-19	0.00E+00	0.00E+00	0.00E+00
Pu 239	2.83E+05	2.96E+05	2.96E+05	2.96E+05	2.96E+05	2.96E+05	2.96E+05	2.96E+05	2.96E+05	2.96E+05	2.95E+05	2.94E+05	2.92E+05	2.88E+05	2.23E+05	1.69E+04	2.13E-06	1.36E-06
Pu 240	6.41E+05	6.40E+05	6.40E+05	6.40E+05	6.40E+05	6.39E+05	6.39E+05	6.38E+05	6.37E+05	6.35E+05	6.28E+05	6.21E+05	6.08E+05	5.77E+05	2.23E+05	1.65E+01	1.77E-04	1.64E-04
Pu 241	6.83E+07	5.36E+07	4.20E+07	3.30E+07	2.59E+07	1.59E+07	9.81E+06	6.04E+06	2.29E+06	5.34E+05	4.18E+03	4.03E+01	7.52E+00	7.22E+00	3.47E+00	2.25E-03	0.00E+00	0.00E+00
Pu 242	1.33E+03	1.33E+03	1.33E+03	1.33E+03	1.33E+03	1.33E+03	1.33E+03	1.33E+03	1.33E+03	1.33E+03	1.33E+03	1.33E+03	1.32E+03	1.32E+03	1.30E+03	1.10E+03	2.07E+02	1.15E-05
Pu 243	2.43E+08	2.13E-06	2.13E-06	2.13E-06	2.13E-06	2.13E-06	2.13E-06	2.13E-06	2.13E-06	2.13E-06	2.13E-06	2.13E-06	2.13E-06	2.13E-06	2.13E-06	2.12E-06	2.03E-06	1.36E-06
Pu 244	1.79E-04	1.79E-04	1.79E-04	1.79E-04	1.79E-04	1.79E-04	1.79E-04	1.79E-04	1.79E-04	1.79E-04	1.79E-04	1.79E-04	1.79E-04	1.79E-04	1.79E-04	1.79E-04	1.77E-04	1.64E-04
Pu 246	2.89E-13	4.70E-13	4.70E-13	4.70E-13	4.70E-13	4.69E-13	4.69E-13	4.69E-13	4.68E-13	4.67E-13	4.63E-13	4.59E-13	4.51E-13	4.33E-13	2.04E-13	1.11E-16	0.00E+00	0.00E+00
Am 241	2.27E+04	5.06E+05	8.82E+05	1.17E+06	1.40E+06	1.70E+06	1.87E+06	1.97E+06	2.03E+06	1.99E+06	1.71E+06	1.46E+06	1.06E+06	4.74E+05	3.72E+00	2.37E-03	0.00E+00	0.00E+00
Am 242m	5.50E+02	5.36E+02	5.23E+02	5.10E+02	4.98E+02	4.74E+02	4.51E+02	4.30E+02	3.90E+02	3.36E+02	2.06E+02	1.26E+02	4.70E+01	4.03E+00	2.44E-19	0.00E+00	0.00E+00	0.00E+00
Am 242	3.49E+07	5.34E+02	5.21E+02	5.08E+02	4.96E+02	4.72E+02	4.49E+02	4.28E+02	3.88E+02	3.35E+02	2.05E+02	1.25E+02	4.68E+01	4.01E+00	0.00E+00	0.00E+00	0.00E+00	0.00E+00
Am 243	5.14E+03	5.16E+03	5.16E+03	5.16E+03	5.15E+03	5.15E+03	5.14E+03	5.14E+03	5.13E+03	5.12E+03	5.07E+03	5.02E+03	4.93E+03	4.70E+03	2.02E+03	4.25E-01	2.03E-06	1.36E-06
Am 244	2.30E+06	5.03E-11	3.42E-11	2.33E-11	1.58E-11	7.32E-12	3.39E-12	1.57E-12	3.35E-13	3.32E-14	1.49E-17	0.00E+00	0.00E+00	0.00E+00	0.00E+00	0.00E+00	0.00E+00	0.00E+00
Am 245	1.49E+04	1.05E-09	2.02E-11	3.86E-13	7.38E-15	2.62E-18	0.00E+00	0.00E+00	0.00E+00	0.00E+00	0.00E+00	0.00E+00	0.00E+00	0.00E+00	0.00E+00	0.00E+00	0.00E+00	0.00E+00
Am 246m	1.48E-05	4.70E-13	4.70E-13	4.70E-13	4.70E-13	4.69E-13	4.69E-13	4.69E-13	4.68E-13	4.67E-13	4.63E-13	4.59E-13	4.51E-13	4.33E-13	2.04E-13	1.11E-16	0.00E+00	0.00E+00
Cm 240	4.75E-03	2.06E-23	0.00E+00	0.00E+00	0.00E+00	0.00E+00	0.00E+00	0.00E+00	0.00E+00	0.00E+00	0.00E+00	0.00E+00	0.00E+00	0.00E+00	0.00E+00	0.00E+00	0.00E+00	0.00E+00
Cm 241	1.14E+00	1.97E-17	0.00E+00	0.00E+00	0.00E+00	0.00E+00	0.00E+00	0.00E+00	0.00E+00	0.00E+00	0.00E+00	0.00E+00	0.00E+00	0.00E+00	0.00E+00	0.00E+00	0.00E+00	0.00E+00
Cm 242	9.25E+06	4.40E+03	4.32E+02	4.20E+02	4.10E+02	3.90E+02	3.72E+02	3.54E+02	3.21E+02	2.77E+02	1.69E+02	1.04E+02	3.87E+01	3.31E+00	2.02E-19	0.00E+00	0.00E+00	0.00E+00
Cm 243	1.65E+03	1.46E+03	1.30E+03	1.15E+03	1.02E+03	8.06E+02	6.35E+02	5.01E+02	3.11E+02	1.52E+02	1.41E+01	1.30E+00	1.11E-02	7.43E-08	0.00E+00	0.00E+00	0.00E+00	0.00E+00
Cm 244	2.64E+05	2.19E+05	1.80E+05	1.49E+05	1.23E+05	8.39E+04	5.73E+04	3.90E+04	1.82E+04	5.76E+03	1.25E+02	2.73E+00	1.29E-03	6.29E-12	0.00E+00	0.00E+00	0.00E+00	0.00E+00
Cm 245	7.82E+00	7.82E+00	7.81E+00	7.81E+00	7.81E+00	7.80E+00	7.79E+00	7.79E+00	7.78E+00	7.76E+00	7.69E+00	7.63E+00	7.51E+00	7.21E+00	3.46E+00	2.24E-03	0.00E+00	0.00E+00
Cm 246	2.14E+00	2.14E+00	2.14E+00	2.14E+00	2.14E+00	2.14E+00	2.13E+00	2.13E+00	2.12E+00	2.11E+00	2.08E+00	2.05E+00	1.99E+00	1.85E+00	5.00E-01	1.02E-06	0.00E+00	0.00E+00
Cm 247	2.13E-06	2.13E-06	2.13E-06	2.13E-06	2.13E-06	2.13E-06	2.13E-06	2.13E-06	2.13E-06	2.13E-06	2.13E-06	2.13E-06	2.13E-06	2.13E-06	2.13E-06	2.12E-06	2.03E-06	1.36E-06
Cm 248	3.19E-06	3.19E-06	3.19E-06	3.19E-06	3.19E-06	3.19E-06	3.19E-06	3.19E-06	3.19E-06	3.19E-06	3.19E-06	3.19E-06	3.19E-06	3.18E-06	3.12E-06	2.61E-06	4.35E-07	7.12E-15
Cm 250	2.59E-12	2.61E-12	2.61E-12	2.61E-12	2.61E-12	2.61E-12	2.60E-12	2.60E-12	2.60E-12	2.59E-12	2.57E-12	2.55E-12	2.51E-12	2.40E-12	1.13E-12	6.17E-16	0.00E+00	0.00E+00
Bk 247	1.08E-14	1.08E-14	1.08E-14	1.08E-14	1.07E-14	1.07E-14	1.06E-14	1.06E-14	1.05E-14	1.03E-14	9.81E-15	9.33E-15	8.44E-15	6.56E-15	7.14E-17	0.00E+00	0.00E+00	0.00E+00
Bk 248	7.39E-11	5.02E-11	3.42E-11	2.33E-11	1.58E-11	7.32E-12	3.39E-12	1.57E-12	3.35E-13	3.32E-14	1.49E-17	6.70E-21	1.11E-27	0.00E+00	0.00E+00	0.00E+00	0.00E+00	0.00E+00
Bk 249	3.78E-03	7.26E-05	1.39E-06	2.66E-08	5.09E-10	1.86E-13	6.83E-17	2.50E-20	0.00E+00	0.00E+00	0.00E+00	0.00E+00	0.00E+00	0.00E+00	0.00E+00	0.00E+00	0.00E+00	0.00E+00
Bk 250	4.45E-02	1.29E-11	3.38E-13	2.10E-13	2.09E-13	2.09E-13	2.08E-13	2.08E-13	2.08E-13	2.07E-13	2.06E-13	2.04E-13	2.01E-13	1.92E-13	9.07E-14	4.93E-17	0.00E+00	0.00E+00
Cf 248	4.50E-10	1.04E-11	2.34E-13	5.25E-15	1.18E-16	5.92E-20	2.91E-23	1.21E-26	0.00E+00	0.00E+00	0.00E+00	0.00E+00	0.00E+00	0.00E+00	0.00E+00	0.00E+00	0.00E+00	0.00E+00
Cf 249	3.72E-07	9.59E-06	9.67E-06	9.58E-06	9.49E-06	9.30E-06	9.12E-06	8.94E-06	8.59E-06	8.10E-06	6.65E-06	5.46E-06	3.68E-06	1.37E-06	2.61E-14	0.00E+00	0.00E+00	0.00E+00

Table 31: Zircaloy Cladding - Total Radionuclide Activity (Bq/Initial kg Zr)**290 MWh/kgU, 720 kW/bundle**

Nuclide	0.0 Yrs	5.0 Yrs	10.0 Yrs	15.0 Yrs	20.0 Yrs	30.0 Yrs	40.0 Yrs	50.0 Yrs	70.0 Yrs	100.0 Yrs	200.0 Yrs	300.0 Yrs	500.0 Yrs	1.0E3 Yrs	1.0E4 Yrs	1.0E5 Yrs	1.0E6 Yrs	1.0E7 Yrs
Cf 250	1.12E-04	8.72E-05	6.69E-05	5.13E-05	3.94E-05	2.32E-05	1.36E-05	8.03E-06	2.78E-06	5.67E-07	2.83E-09	1.43E-11	2.01E-13	1.92E-13	9.07E-14	4.94E-17	0.00E+00	0.00E+00
Cf 251	3.39E-07	3.38E-07	3.37E-07	3.35E-07	3.34E-07	3.32E-07	3.29E-07	3.27E-07	3.22E-07	3.14E-07	2.91E-07	2.69E-07	2.31E-07	1.57E-07	1.51E-10	0.00E+00	0.00E+00	0.00E+00
Cf 252	9.54E-05	2.57E-05	6.94E-06	1.87E-06	5.05E-07	3.67E-08	2.67E-09	1.94E-10	1.03E-12	3.95E-16	0.00E+00	0.00E+00	0.00E+00	0.00E+00	0.00E+00	0.00E+00	0.00E+00	0.00E+00
Cf 254	3.14E-07	2.57E-16	1.95E-25	0.00E+00	0.00E+00	0.00E+00	0.00E+00	0.00E+00	0.00E+00	0.00E+00	0.00E+00	0.00E+00	0.00E+00	0.00E+00	0.00E+00	0.00E+00	0.00E+00	0.00E+00
Es 252	4.82E-14	3.29E-15	2.25E-16	1.53E-17	1.05E-18	4.89E-21	2.28E-23	1.06E-25	0.00E+00	0.00E+00	0.00E+00	0.00E+00	0.00E+00	0.00E+00	0.00E+00	0.00E+00	0.00E+00	0.00E+00
Es 254	1.20E-09	1.27E-11	1.29E-13	1.31E-15	1.33E-17	1.30E-21	1.32E-25	0.00E+00	0.00E+00	0.00E+00	0.00E+00	0.00E+00	0.00E+00	0.00E+00	0.00E+00	0.00E+00	0.00E+00	0.00E+00
Es 255	8.58E-09	1.32E-22	0.00E+00	0.00E+00	0.00E+00	0.00E+00	0.00E+00	0.00E+00	0.00E+00	0.00E+00	0.00E+00	0.00E+00	0.00E+00	0.00E+00	0.00E+00	0.00E+00	0.00E+00	0.00E+00
Total¹²	2.55E+13	9.99E+10	4.08E+10	1.97E+10	1.08E+10	4.42E+09	2.55E+09	1.84E+09	1.30E+09	9.76E+08	5.20E+08	3.18E+08	1.68E+08	1.15E+08	6.63E+07	3.37E+07	1.83E+07	3.14E+05

¹² Note: the total at time zero represents the total activity of those nuclides presented only. The activity from short-lived nuclides (that are not listed) is not included in this total.

Table 32: Total Thermal Power for UO₂ Fuel and Zircaloy Cladding

290 MWh/kgU, 720 kW/bundle

	0.0 Yrs	5.0 Yrs	10.0 Yrs	15.0 Yrs	20.0 Yrs	30.0 Yrs	40.0 Yrs	50.0 Yrs	70.0 Yrs	100.0 Yrs	200.0 Yrs	300.0 Yrs	500.0 Yrs	1.0E3 Yrs	1.0E4 Yrs	1.0E5 Yrs	1.0E6 Yrs	1.0E7 Yrs
UO₂ Fuel (W/Initial kg U)	2.15E+03	6.29E-01	3.49E-01	3.04E-01	2.76E-01	2.32E-01	1.97E-01	1.70E-01	1.29E-01	9.30E-02	5.53E-02	4.64E-02	3.75E-02	2.53E-02	8.28E-03	4.45E-04	1.67E-04	1.02E-04
Zircaloy Cladding (W/Initial kg Zr)	1.66E+01	2.01E-02	9.95E-03	5.04E-03	2.59E-03	7.00E-04	1.99E-04	6.34E-05	1.52E-05	9.23E-06	5.92E-06	4.86E-06	3.96E-06	3.16E-06	1.67E-06	2.65E-07	8.92E-08	5.92E-09